

WKV

150 - 230
300 - 348

General Information

Warning: this manual contains instructions to be used exclusively by the installer and/or a competent person in accordance with the current laws in force. The end user MUST not make any alterations to the boiler.

Failure to follow the instructions indicated in this manual, which is supplied with the boiler, could cause injury to persons, animals or damage to property. The manufacturer shall not be held liable for any injury and/or damage.

CONTENTS

1	GENERAL INFORMATIONI	3
1.1	Symbols used in this manual	3
1.2	Correct use of the appliance	3
1.3	Water treatment	3
1.4	Information to be handed over to the user or the person in charge of the appliance.....	3
1.5	Safety warnings	4
1.6	Data plate	5
1.7	General warnings.....	6
2	TECNICAL FEATURES AND MACHINES.....	7
2.1	Tecnical featurers	7
2.2	Dimensions	8
2.3	Performance data	10
2.4	Main components	11
3	INSTRUCTIONS FOR THE INSTALLER.....	12
3.1	General warnings	12
3.2	Standard codes of installation	13
3.3	Packaging.....	14
3.4	Handling and lifting.....	15
3.5	Installation on existing heating system	15
3.6	Boiler location.....	16
3.7	Chimney conection.....	16
3.8	Condensaet drainage	18
3.9	Boiler connection	19
3.10	Gas conection	20
3.11	System connection	21
3.12	Determination of primary circuit pump or boiler system pump	22
3.13	Frost protection	23
3.14	Mixing header and plate heat exchanger.....	26
3.15	Water treatment	27
3.16	Casing assembly	28
3.17	Filling the system.....	28
3.18	Electrical connections	29
3.19	Functional low wiring diagram.....	31
3.20	Types of installation.....	32
3.21	Electrical panel	34
3.22	Wiring connection for electrical panel	35
3.23	Wiring connection panel within multiinox Master + Slave	35
3.24	Table positioning selector and cards.....	37
3.25	Installation examples	38
3.26	Initial lighting.....	41
3.27	Burner pressure adjustment.....	42
3.28	Test mode.....	44
3.29	Programming of the operating modes	46
3.30	Operatività di emergenza e sicurezze	48
4	INSPECTION AND MAINTENANCE	49
6	CE CERTIFICAT	52

1

GENERAL INFORMATION

1.1 - SYMBOLS USED IN THIS GUIDE

When reading this guide particular care has to be given to the parts marked with the followings symbols:



DANGER!
Indicates serious danger for your personal safety and for your life



WARNING!
Indicates a potentially dangerous situation for the product and the environment



NOTE!
Suggestions for the user

1.2 - CORRECT USE OF THE APPLIANCE



The WKV appliance has been designed utilizing today's heating technology and in compliance with the current safety regulations. However, following an improper use, dangers could arise for the safety and life of the user or of other people, or damage could be caused to the appliance or other objects. The appliance is designed to be used in pumped hot water central heating systems. Any other use of this appliance will be considered improper. The manufacturer declines any responsibility for any damages or injuries caused by an improper use; in this case the risk is completely at the user's responsibility. In order to use the appliance according to the scopes it was designed for it is essential to carefully follow the instructions indicated in this guide.

1.3 - WATER TREATMENT (refer to specific guide)



- The hardness of the mains water supply conditions the frequency with which the heat exchanger is cleaned.
- In hard water areas where the main water can exceed 15°f total hardness, a scale reducing device is recommended. The choice of this device has to be made taking into consideration the characteristics of the water.
- We recommend you to check the state of cleanliness of the domestic hot water heat exchanger at the end of the first year and subsequently every two years; in this occasion check the state of wear of the anode.

1.4 - INFORMATION TO BE HANDED OVER TO THE USER



The user has to be instructed on the use and operation of his heating system, in particular:

- Hand over these instructions to the end user, together with any other literature regarding this appliance, placed inside the envelope contained in the packaging. **The user has to keep these documents in a safe place in order to always have them at hand for future reference.**
- Inform the user on the importance of air vents and of the flue outlet system, stressing the fact that is absolutely forbidden to make any alterations to the boiler.
- Inform the user how to check the system's water pressure as well as informing him how to restore the correct pressure.
- Explain the function of time and temperature controls, thermostats, heating controls and radiators, to ensure the greatest possible fuel economy.
- Remind the user that it is obligatory to carry out a comprehensive service annually and a combustion analysis every two years (in compliance with the national law).
- If the appliance is sold or transferred to another owner or if the present user moves home and leaves the appliance installed, ensure yourself that the manual always follows the appliance so that it can be consulted by the new owner and/or installer.

Failure to follow the instructions indicated in this guide, which is supplied with the boiler, could cause injury to persons, animals or damage to property. The manufacturer shall not be held liable for any such injury and/or damage.

General Information

1.4 - SAFETY WARNINGS



WARNING!

The device should not be used by people with reduced physical, mental and sensory, experience and knowledge. These people must be well-informed and supervised during the work. Children must be supervised so they do not play with the appliance.



WARNING!

The installation, adjustment, and servicing of this appliance must be carried out by a competent person and installed in accordance with the current standards and regulations. Failure to correctly install this appliance could cause injury to persons, animals or damage to property. The manufacturer shall not be held liable for any injury and/or damage.



DANGER!

Servicing or repairs of the appliance must be carried out by the manufacturer authorised service technicians; The manufacturer recommends drawing up a service contract. Bad or irregular servicing could compromise the safe operation of the appliance, and could cause injury to persons, animals or damage to property for which the manufacturer shall not be held liable.



Modifications to parts connected to the appliance

Do not carry out any modifications to the following parts:

- the boiler
- to the gas, air, water supply pipes and electrical current
- to the flue pipe, safety relief valve and its drainage pipe
- to the constructive components which influence the appliance's safe operation



WARNING!

When tightening or loosening the screw pipe connections, use only adequate fork spanners. The improper use and/or the use of inadequate equipment can cause damages (for example water or gas leakages).



WARNING!

Indications for appliances operating with propane gas

Ensure yourself that before installing the appliance the gas tank has been purged.

For a correct purging of the tank contact the liquid gas supplier or a competent person who has been legally authorized.

If the tank has not been correctly purged problems could occur during ignition.

If this occurs contact the liquid gas tank's supplier.



Smell of gas

If you smell gas follow these safety indications:

- Do not turn on or off electrical switches
- Do no smoke
- Do not use the telephone
- Close the main gas tap
- Open all windows and doors where the gas leakage has occurred
- Inform the gas society or a company specialized in installing and servicing heating systems



Explosive and easily inflammable substances

Do not use or leave explosive or easily inflammable material (as for example: petrol, paint, paper) in the room where the appliance has been installed.

1.7 - DATA PLATE

The data plate can be found underneath the casing above the first module's electrical box, a duplicate of the same data plate can be found on the control instrument's inside door.

CE Marking

The CE marking documents that the boilers satisfy:

- The essential requirements of the Directive regarding gas appliances (Directive 2009-142 EC)

- The essential requirements of the Directive regarding electromagnetic compatibility (Directive 2004/108 EC)
- The essential requirements of the Efficiency Directive (Directive 92/42/EEC)
- The essential requirements of the low voltage Directive (Directive 2006/95EC).

The data plate is divided into several sections:

- Top:** CE mark with a circled '1' and a star in a box.
- Section 2:** Model (3), CEE 92/42 stars (4), S.N° (5), PIN (6), Types (7), NOx (8).
- Section A (Central Heating):** Pn (9) kW, Pcond (10) kW, Qmax (11) kW, Adjusted Qn (12) kW, PMS (13) bar, T max (14) °C.
- Section B (Domestic hot water):** Qnw (15) kW, D (16) l/min, R factor (17), F factor (18), PMW (19) bar, T max (20) °C.
- Section C (Electrical Power supply):** (21) V, Hz, (22) W, IP class: (23).
- Section D (Countries of destination):** (24), (25), (26).
- Section E (Factory setting):** (27) mbar with seven checkboxes.
- Bottom:** A dashed box labeled (28) with an arrow pointing to it. A warning symbol and an information symbol are also present.

LEGEND:

- | | | | |
|------|--|------|---|
| 1 = | Year of CE certification issue | 17 = | (R factor) N° taps based on the quantity of water declared EN 13203-1 |
| 2 = | Boiler type | 18 = | (F factor) N° stars based on the quality of water declared EN 13203-1 |
| 3 = | Boiler model | 19 = | (PMW) Max. pressure D.H.W. system |
| 4 = | Number of stars (Directive 92/42/CEE) | 20 = | (T max) Max. temperature D.H.W system |
| 5 = | (S.N°) Serial number | C = | Electrical features |
| 6 = | P.I.N. code | 21 = | Electrical power supply |
| 7 = | Approved fluing configurations | 22 = | Consumption |
| 8 = | (NOx) NOx class | 23 = | Protection grade |
| A = | Central Heating circuit features | D = | Countries of destination |
| 9 = | (Pn) Nominal output | 24 = | Direct and indirect country of destination |
| 10 = | (Pcond) Condensing nominal output | 25 = | Gas family |
| 11 = | (Qmax) Nominal heat input | 26 = | Supply pressure |
| 12 = | (Adjusted Qn) Adjusted for nominal Heat input | E = | Factory setting |
| 13 = | (PMS) Max. pressure C.H. system | 27 = | Adjusted for gas type X |
| 14 = | (T max) Max. C.H. temperature | 28 = | Space for national brands |
| B = | Domestic Hot Water circuit features | | |
| 15 = | (Qnw) Nominal heat input in D.H.W. mode (if different from Qn) | | |
| 16 = | (D) Specific D.H.W. flow rate according to EN 625 - EN 13203-1 | | |

General Information

WARNING

If the boiler operates with a forced draught gas burner, the appliance, not appertaining to any category contemplated in the annexe II of the legislative decree n°93 dated 25/02/2000 (implementation of the PED Directive 97/23/EC), and moreover also being contemplated in the Gas Appliances Directive 90/396/EEC), to which the art. 1, comma 3 paragraph "f.5" refers to, results as being excluded from the scope of the same decree.

1.7 - GENERAL WARNING

This instruction manual is an integral and indispensable part of the product and must be retained by the person in charge of the appliance.

Please read carefully the instructions contained in this manual as they provide important indications regarding the safe installation, use and servicing of this appliance.

Keep this manual in a safe place for future reference.

The installation and servicing must be carried out in accordance with the regulations in force according to the manufacturer's instructions and by registered engineers or installers.

By a competent person, we imply a person who has a specific technical qualification in the field of components for central heating systems for domestic use, domestic hot water production and servicing. The person must have the qualifications foreseen by the current laws in force.

Bad or irregular servicing could compromise the safe operation of the appliance, and could cause injury to persons, animals or damage to property. The manufacturer shall not be held liable for any such injury and/or damage.

Before carrying out any cleaning or servicing turn off the electrical supply to the boiler by means of the ON/OFF switch and/or by means of the appropriate shutdown devices.

Do not obstruct the intake/outlet terminal ducts.

In the event of failure and/or faulty functioning of the appliance, switch off the boiler. Do not attempt to make any repairs: contact qualified technicians.

Any repairs must be carried out by authorized service engineers and using only original spare parts. Non-observance of the above requirement may jeopardize the safety of the appliance.

To guarantee the efficiency and correct functioning of the appliance it is indispensable to have the boiler serviced annually by a qualified person.

If the boiler remains unused for long periods, ensure that any dangerous parts are rendered innocuous.

If the appliance is sold or transferred to another owner or if the present user moves home and leaves the appliance installed, ensure yourself that the manual always follows the appliance so that it can be consulted by the new owner and/or installer.

Only original accessories must be used for all appliances supplied with optionals or kits (including electrical ones).

This appliance must be used only for the purposes for which it has been expressly designed. Any other use shall be considered incorrect and therefore dangerous

2

TECHNICAL FEATURES AND DIMENSIONS

2.1 - TECHNICAL FEATURES

The WKV series is made up of gas heating units and very low condensing temperature according to dir. 92/42, made entirely of stainless steel, high water content, complete with modulating burner premix.

Efficiency class: ★★★★★ (4) stars

Power supplye 150 to 348 kW

Performance in condensation, more than 107% to 100% and 109% load at 30% load, thanks to the special pipes patented progressive.

The components of the parts under pressure, such as steel plates and pipes, are built in stainless steel 316L, according to the tables EURONORM 25 and EURONORM 28.

The welders and the welding processes have been approved by TUV (GE) - UDT (PL) - SD (S) and ISPESL (IT).

- Horizontal direct-fired hearth;
- Tube bundle consisting of armored tubes patented progressive 316L stainless steel exterior with aluminum inner blades, placed in vertical tube bundle 1: functional drainage of condensate, the absence of acid deposition wet cleaning severity of heat transfer surfaces;
- Double return for medium and low temperature in the lower back;
- Smoke chamber with stainless steel condensate drain connection and condensate level sensor;
- Opening the door to the left with the possibility of change of rotation;
- Control panel and electronic HSCP Master (Heating System Control Panel), external to the mantle, with temperature control unit eBus placed vertically at the side door, single boiler code:
00362322 for WKV150
00362321 for WKV230
00362320 for WKV300
00362318 for WKV348

- For boilers in battery (up to 7), control panel and electronic slave, external to the mantle, placed vertically at the side door code:
00362326 for WKV150
00362325 for WKV230
00362324 for WKV300
00362323 for WKV348
- External shell covered with a layer of mineral wool 80 mm thick in turn protected by a tissue mineral fiber;
- Attack 2 ½ "conduit with an inner diameter of 15 mm (suitable for housing 3 bulbs each);
- Sides of the coat fitted with holes for cable glands for power cables and any other assistive device;
- Total premix burner built in AISI 441 and coated with special fiber:
- Mixing air / gas ratio of 1:1 range of modulation (modulation ratio greater than 1:4);
- mixing system upstream of the fan, which ensures proper operation even with low gas supply pressures (up to 13 mbar);
- reduced power consumption compared to a conventional forced draft burner;
- Very low emission combustion.

Optional kits:

Neutral Kit NH300 - part number: 00262827 for appliances up to 300 kW

Neutral Kit NH1500-P part number: 00262829 for appliances upto 300 kW

MODULE MANAGER CASCADE BCM - code 00361602

MODULE SHC (slave heating controller) - code 00362317

Technical features and dimensions

2.2 - MAIN COMPONENTS AND FUNCTIONING

The WKV boilers are built with a blind furnace, in which the burner's central flame travels towards the bottom and then is distributed in the flue pipes; at the terminal part of the pipes the combustion gas is collected in the flue chamber and then sent to the chimney. During burner operation, within the boiler's output range, the combustion chamber is always under positive pressure.

For this pressure value refer to the table on page 8, to the column "Heating losses flue side".

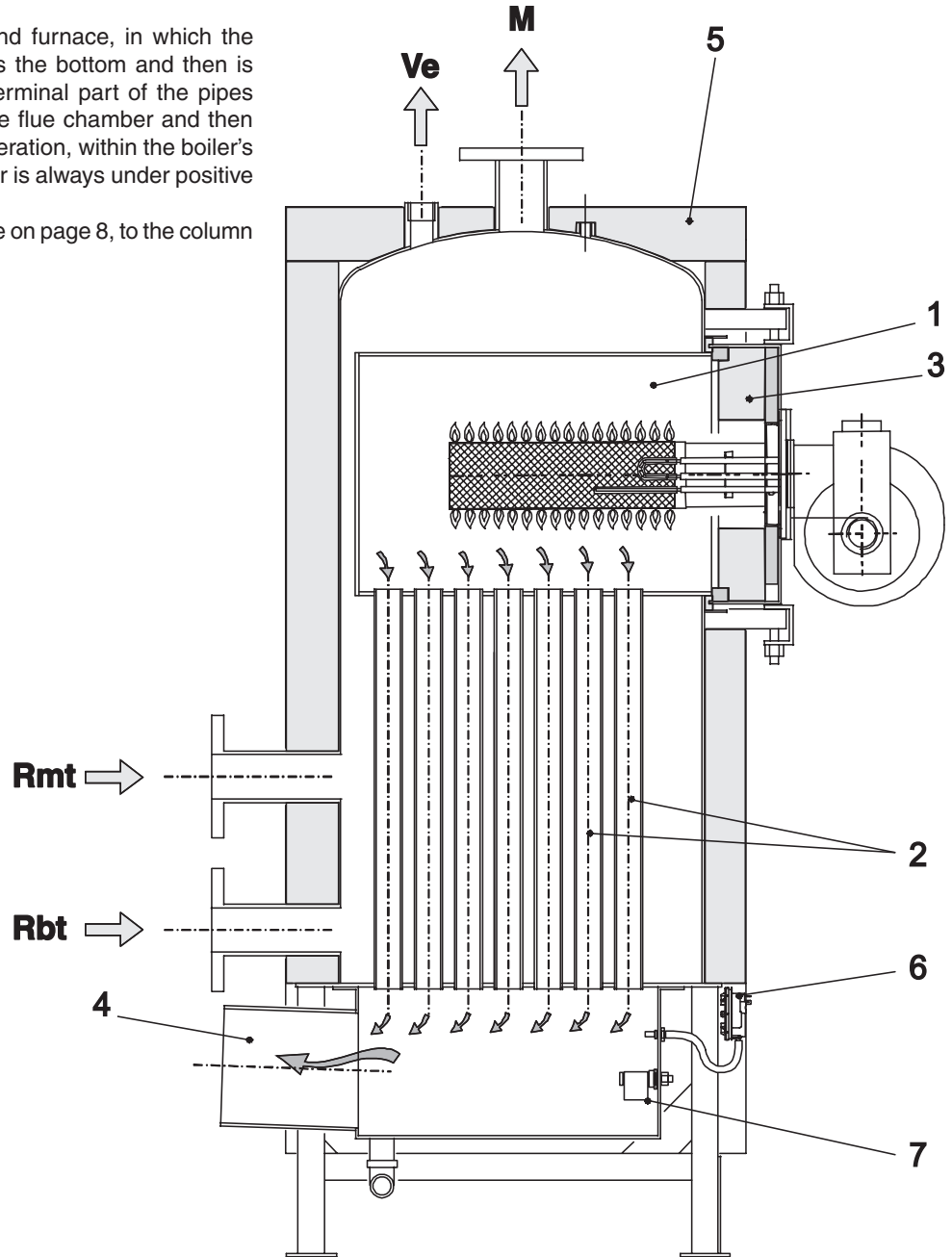

- 1. Furnace
- 2. Flue pipes with flue deflectors
- 3. Door complete with flame control light
- 4. Smoke chamber
- 5. Body insulation
- Control panel (not visible)
- M System flow
- Rbt Low temperature system return
- Rmt Average temperature system return
- Ve Expansion vessel

2.3 - DIMENSIONS

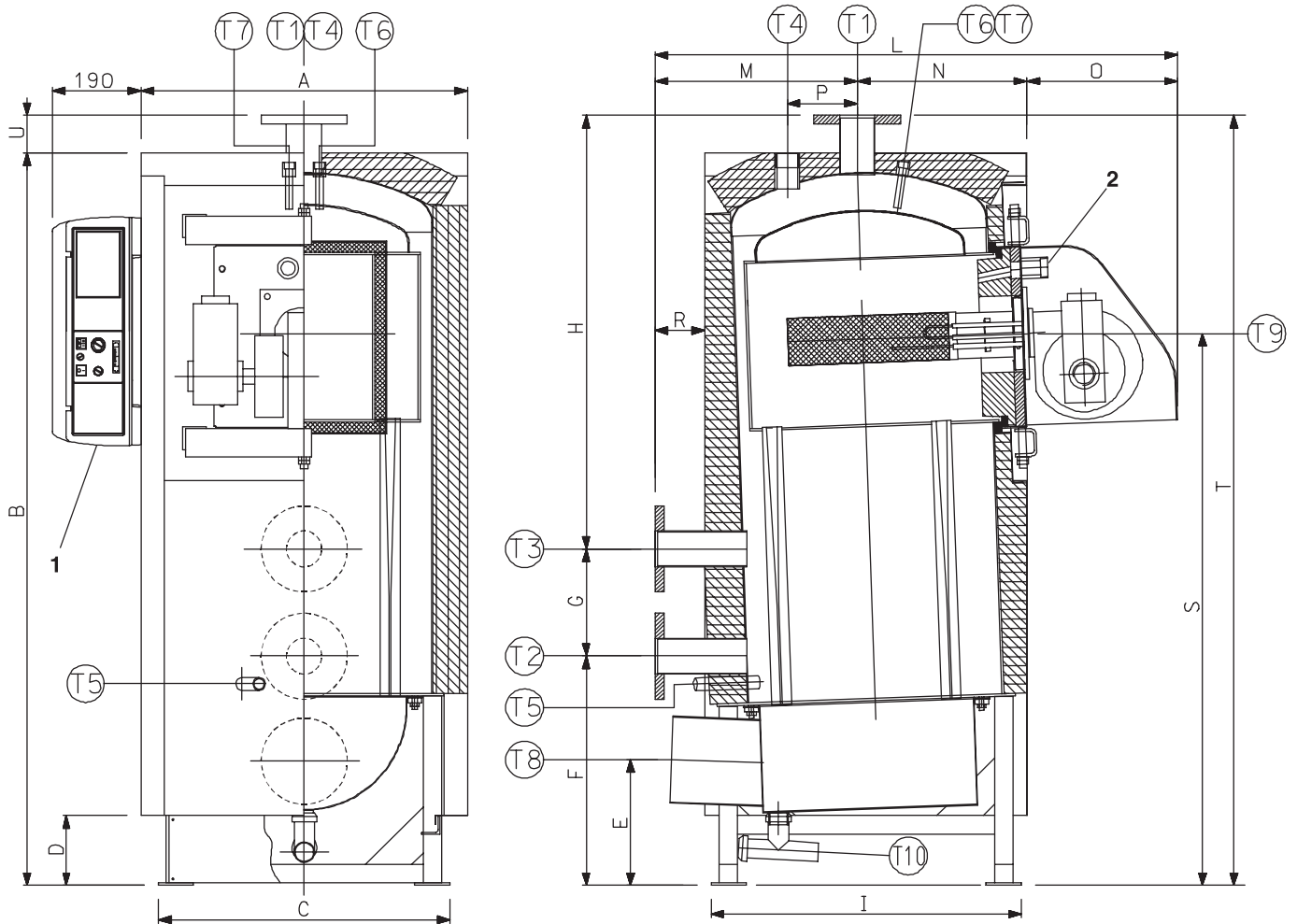

- 1 Control box
- 2 Flame control sight glass

- T1 C.H flow
- T2 Average temperature system return
- T3 Low temperature system return
- T4 Expansion vessel connection
- T5 Boiler drainage

- T6 Cable sheathing leads bulbs
- T7 Cable sheathing leads bulbs
- T8 Chimney connection
- T9 Burner connection
- T10 Condensate drain

WKV	Heat output (50°-30°C)	Heat output (80°-60°C)	Furnace Output	Boiler Volume	Water side losses (**)	Flue side losses	Max boiler working pressure	Weight without burner	Gas pressure (***)	CONNECTIONS						
										T1,T2,T3	T4	T5	T6,T7	T8	T9	T10
Model	kW	kW	kW	l	m c.a.	mm c.a.	bar	kg	mbar	UNI 2278 PN16	ISO 7/1	ISO 7/1	Øi mm	Øi mm	Øi mm	Øe mm
150	150	136,5	140	151	0,27	35	5	310	20	65	1½	¾	163	180	163	40
230	230	209,2	215	257	0,32	40	5	447	20	65	1½	¾	163	180	163	40
300	300	273,6	279,3	317	0,55	45	5	540	20	80	2	¾	163	200	163	40
348	348	317,7	532,4	389	0,60	50	5	661	20	80	2	¾	163	200	163	40

WKV	DIMENSIONS																		
	Model	A	B	C (*)	D	E	F	G	H	I	L	M	N	O	P	R	S	T (*)	U
		mm	mm	mm	mm	mm	mm	mm	mm	mm	mm	mm	mm	mm	mm	mm	mm	mm	mm
150		700	1570	625	150	270	491	230	929	685	1147	433	364	350	150	107	1183	1650	80
230		830	1670	755	150	270	491	230	1044	815	1277	503	454	320	170	107	1209	1765	95
300		880	1830	795	160	305	556	250	1024	855	1329	526	483	320	170	109	1300	1920	90
348		960	1860	875	160	332	586	250	1114	965	1429	576	533	320	170	109	1333	1950	90

(*) Minimum dimensions for boiler room access requirements.

(**) Hydraulic resistance for delta T 15K.

(***) Minimum pressure gas train entrance (natural gas - G20)

Technical features and dimensions

2.4 - PERFORMANCE DATA

BOILER TYPE		WKV150	WKV230	WKV300	WKV348
Boiler family gas category II 2H3P	l _{2H}				
Nominal heat input on LCV Q _n	kW	140	214	280	324
Minimum heat input on LCV Q _{min}	kW	35	50	70	70
Nominal heat output (Tr 60/Tm 80°C) P _n	kW	136,5	209,2	273,6	317,7
Minimum heat output (Tr 60/Tm 80°C) P _{n min}	kW	34,3	49	68,4	68,5
Nominal heat output (Tr30/Tm 50°C) P _{cond}	kW	150	230	300	348
Minimum heat output (Tr 630/Tm 50°C) P _{cond min}	kW	38,1	54,5	76,1	76,1
Efficiency at nominal output (Tr 60/Tm 80°C)	%	97,5	97,7	97,9	98,0
Efficiency at minimum output (Tr 60/Tm 80°C)	%	98,0	98,0	97,7	97,8
Efficiency at nominal output (Tr30/Tm 50°C)	%	107,1	107,4	107,4	107,4
Efficiency at minimum output (Tr30/Tm 50°C)	%	108,8	109	108,7	108,7
Efficiency at partial load 30% (Tr 30°C)	%	109	109	109	109
Efficiency Class		4	4	4	4
Efficiency at 100%	%	97,27	98,20	98,20	98,20
Efficiency at partial load 100% (30%)	%	95,41	96,81	96,81	96,81
Combustion efficiency at nominal load	%	97,5	97,9	97,5	98,0
Combustion efficiency at reduced load	%	98,5	98,5	98,5	98,5
Flue losses with burner On	%	0,5	0,5	0,7	0,6
Flue losses with burner Off	%	0,1	0,1	0,1	0,1
Flue gas temperature t _{f-ta} (min)	°C	30	30	30	30
Flue gas temperature t _{f-ta} (max)	°C	50	50	50	50
Flue gas mass flow rate (min)	kg/h	57,2	80,97	114,4	11,4
Flue gas mass flow rate (max)	kg/h	228,8	346,5	457,6	529,5
Air excess	%	25,53	24,25	25,53	25,53
CO ₂ (min)	%	9,1	9,2	9,1	9,1
CO ₂ (max)	%	9,1	9,2	9,1	9,1
N0x (value according to EN 297/A3)	mg/kWh	47,83	68,65	89,7	83,8
N0x class		5	5	4	4
Heat loss at chimney with burner on (min)	%	1,5	1,48	1,5	1,5
Perdite al camino con bruciatore funzionante (max)	%	2,5	2,1	2,5	2
Heat loss at chimney with running burner (max)	%	0,1	0,1	0,1	0,1
Water flow rate at nominal output (delta T 20°C)	l/h	5870	8994	11781	13660
Minimum pressure CH circuit	bar	0,5	0,5	0,5	0,5
Maximum pressure CH circuit	bar	6	6	6	6
Water content	l	151	257	317	389
Natural gas consumption G20 (20mbar) at Q _n	m ³ /h	14,8	22,63	29,61	34,26
Natural gas consumption G20 (20mbar) at Q _{min}	m ³ /h	3,70	5,29	7,40	7,40
G25 gas consumption (20/25 mbar) at Q _n	m ³ /h	17,22	26,32	34,43	39,85
G25 gas consumption (20/25 mbar) at Q _{min}	m ³ /h	4,30	6,15	8,61	8,61
Propane gas consumption (37/50 mbar) at Q _n	kg/h	10,87	16,61	21,73	25,15
Propane gas consumption (37/50 mbar) at Q _{min}	kg/h	2,72	3,88	5,43	5,43
Max. available pressure at chimney base	Pa	100	100	100	100
Max. condensate production (15°C)	kg/h	22,54	34,45	45,08	52,16
Emissions					
CO at 0% of O ₂ in the flue gasses	ppm	19	19	10	10
NOx with 0% of O ₂ in the flue gasses	ppm	45	76	61	58
Electrical data					
Electrical supply	V/Hz	230/50	230/50	230/50	230/50
Fuse rating	A (F)	6,3	6,3	6,3	6,3
Maximum/Minimum absorbed power	W	280	300	315	370
Electrical protection	IP	20	20	20	20
Stand-by consumption	W	18	18	18	18

(*) Room temperature = 20°C

(**) See table "INJECTORS-PRESSURES"

3

INSTRUCTIONS FOR THE INSTALLER

3.1 - GENERAL WARNINGS



This boiler has to be destined for the use for which it has been expressly designed for. Any other use shall be considered improper and therefore dangerous.

This boiler is designed to heat water at a temperature inferior to boiling point at an atmospheric pressure.



WARNING!

These appliances are exclusively designed to be installed inside adequate boiler rooms.



Before installing the boiler the following points have to be carried out by a competent engineer:

- a) The whole system should be thoroughly flushed in order to remove any residual dirt or grime which could compromise the good operation of the boiler, even from a hygienical point of view.
- b) Check that the boiler has been preset for operating with the gas type available. This is verifiable via the indication on the packaging and on the data badge;
- c) Check that the chimney/flue pipe has an adequate draught, does not have any constrictions, and that no other appliance's flue outlets have been fitted, unless the chimney is serving more than one heating appliance, according to the specific standards and regulations in force.



The connection between the boiler and chimney/flue outlet can be made only after this verification has been carried out.



WARNING!

In rooms where aggressive vapours or dust is present, the appliance must operate independently from the air present in the boiler's location room!



WARNING!

The appliance must be installed by a registered engineer or gas installer.



The boiler must be connected to a heating system which is compatible to its performance and output.

3

INSTRUCTIONS FOR THE INSTALLER

3.1 - GENERAL WARNINGS



This boiler has to be destined for the use for which it has been expressly designed for. Any other use shall be considered improper and therefore dangerous.

This boiler is designed to heat water at a temperature inferior to boiling point at an atmospheric pressure.



WARNING!

These appliances are exclusively designed to be installed inside adequate boiler rooms.



Before installing the boiler the following points have to be carried out by a competent engineer:

- a) The whole system should be thoroughly flushed in order to remove any residual dirt or grime which could compromise the good operation of the boiler, even from a hygienical point of view.
- b) Check that the boiler has been preset for operating with the gas type available. This is verifiable via the indication on the packaging and on the data badge;
- c) Check that the chimney/flue pipe has an adequate draught, does not have any constrictions, and that no other appliance's flue outlets have been fitted, unless the chimney is serving more than one heating appliance, according to the specific standards and regulations in force.



The connection between the boiler and chimney/flue outlet can be made only after this verification has been carried out.



WARNING!

In rooms where aggressive vapours or dust is present, the appliance must operate independently from the air present in the boiler's location room!



WARNING!

The appliance must be installed by a registered engineer or gas installer.



The boiler must be connected to a heating system which is compatible to its performance and output.

3.2 - STANDARD CODES FOR INSTALLATION

This appliance must be installed in compliance to the manufacturer's instructions and the national regulations in force. Read the instructions fully before installing or using the appliance

In the interests of safety, a competent installer should be employed to effect the installation of the appliance.

Moreover, the installation of the boiler **MUST** be in accordance with the latest wiring regulations local buildings regulations and any relevant requirements regarding central heating plants in force in the country the boiler is installed.

The WKV boilers are a range of heating units in stainless steel foreseen for the II2H3P family gas category.

3.3 - PACKAGING

The WKV boilers are delivered fully complete with door and smoke chamber already fitted, whilst the casing with the insulation mattress is contained in separate cardboard packaging(s). The control panel and accessories are inside the combustion chamber.

Before starting the installation make sure that the length and the width of the boiler body received, indicated in the table on page 8, correspond to the dimensions of the ordered boiler, and that the cartons, containing the casing, or part of it, are marked as indicated below.

The casing of the boilers WKV complete with the insulation mattress, is contained in n°2 cartons. (1 carton for the WKV150).

In addition to the above indicated control panel, packaged in its own carton, in the combustion chamber as accessories, there are also:

- a carton containing the flanges for flow, return and safety connections (if applicable) with relevant gaskets and bolts;
- ceramic fibre rope for the insulation between the door and burner blast tube;
- 1 bag containing the condensate drain kit



After having unpacked the boiler check that it is intact and undamaged.



Keep the packaging material (cardboard box, plastic bags, polyester protection etc.) out of the reach of children as they can be dangerous. The manufacturer refuses all liability for injury to persons, animals or damage to property deriving from not having respected the above mentioned recommendations.

In the packaging, in addition to the boiler, you can also find the following contents:

- Hydraulic test certificate
- Service logbook
- Instruction manual for the person in charge of the appliance
- Instruction manual for the installer and servicing personnel
- Adhesive sticker indicating local venting regulations

ISOLATION AND CASING

N.B. For the model **WKV150**, mantle and isolation are contained in 1 package marked: **38353** (casing insulation VKW150)

N.B. For models **WKV230, WKV300, WKV348** the casing and insulation are contained in 2 packages marked:

37462 (casing side + isolation WKV230)

37463 (casing front. + back + cover WKV230)

38355 (casing side + isolation WKV300)

38354 (casing front. + back + cover WKV300)

37464 (casing side + isolation WKV348)

37465 (casing front. + back + cover WKV348)

CONTROL PANEL

N.B. For the model **WKV150** the control panel is contained in a package marked:

00362322 (control panel with control unit + external probe EBUS)

00362326 (WKV150 control panel "Slave")

N.B. For models **WKV230** the control panel is contained in a package marked:

00362321 (control panel with control unit EBUS + external probe)

00362325 (control panel "Slave")

N.B. For models **WKV300** the control panel is contained in a package marked:

00362320 (control panel with control unit + external probe EBUS)

00362324 (control panel "Slave")

N.B. For models **WKV230** the control panel is contained in a package marked:

00362318 (control panel with control unit EBUS + external probe)

00362323 (control panel "Slave")

ACCESSORIES

N.B. The hydraulic connection flanges with gaskets and bolts are contained in a package marked:

36372 (accessories WKV150 - WKV230)

36373 (accessories WKV300 - WKV348)

N.B. The condensate drain kit is contained in a package labeled: **27982**

Instructions for the installer

3.4 - HANDLING AND LIFTING



The boiler can be moved by lifting, via the holes or upper hooks.

If necessary, due to the dimensions of the boiler, it is possible to remove the front door to facilitate the introduction in the boiler house.

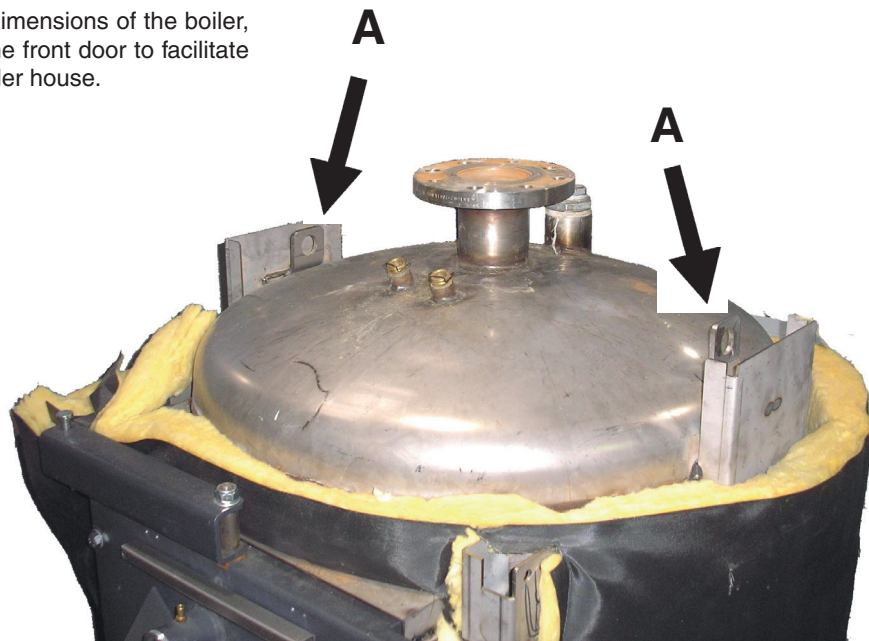

3.5 - INSTALLATION ON EXISTING HEATING SYSTEMS

When the appliance is installed on existing systems, ensure yourself that:

- The flue outlet pipe is suitable for condensing boilers, for the temperature of the products of combustion, calculated and manufactured according to the regulations in force. It must be installed as much as possible in a straight line, tested for soundness, insulated and must not have any occlusions or restrictions.
- The flue outlet pipe has a connection for the discharge of condensate.
- The boiler room has a suitable outlet for the discharge of condensate produced by the boiler.
- The electrical system has been fitted in compliance to the specific standards and the work has been carried out by a competent person.
- The circulation pump's output, the head and flow direction are suitable.
- The gas feed supply pipe and eventual tank are constructed according to the regulations in force.
- The expansion vessels assure the total absorption of the expansion of the fluid contained in the system.
- The system has been cleaned of impurities and lime scale.

3.6 - BOILER LOCATION

The boiler must be installed in accordance with the relevant requirements of the Gas Safety Regulations, current I.E.E. Regulations, local water authority by e-laws and it should also comply with any relevant requirements of the local gas supplier, local authority and the relevant Standard Codes of Practice and building regulations.

The boiler house must be ventilated via permanent openings having a total surface not inferior to 1/30th of the floor area of the boiler house, with a minimum of 0.5 m²

It is advisable to install the boiler as close as possible to the chimney connection on a non combustible floor (i.e. concrete or brick).

To facilitate cleaning of the flue circuit the boiler must have sufficient clearance space in front, not less than the length of the boiler body and, in any case, never less than 1300 mm.

When the door is open 90° the distance between the door and the adjacent wall must be at least equal to the burner length.

The surface must be flat, level, and of a suitable load bearing capacity to support the weight of the boiler (when filled with water - see general data table).

If the boiler is mounted on a plinth then the dimensions (see Frame 2) of the plinth must be at least CxZ (refer to the table dimensions).

Once the boiler has been installed it must be perfectly horizontal and stable (to avoid vibrations and noise).

X = not less than the length of the boiler body (dimensions given

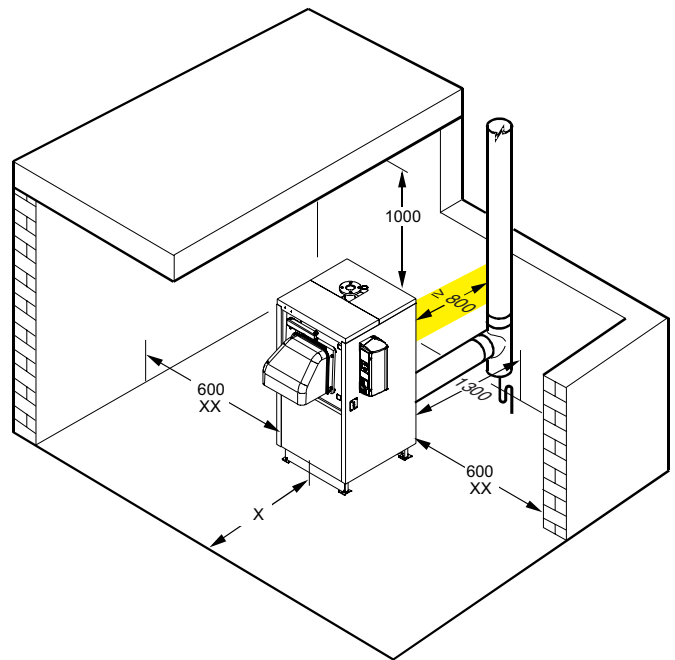

in millimetres); in any case never less than 1300 mm.

XX = see instructions.

3.7 - CHIMNEY FLUE CONNECTION

In condensing boilers the flue gases are evacuated at a very low temperature (max about 84°C). Therefore the chimney must be perfectly impermeable to the condensate of products of combustion and built with suitable materials which are resistant to corrosion.

The different spigot joints must be well sealed and equipped with suitable gaskets, in order to prevent the outlet of condensate and the inlet of air.

Furthermore ensure that the possible condensate or rain water coming from the chimney does not enter the boiler's flue chamber.

Refer to applicable regulations while determining the size and height of the flue.

In order to prevent the formation of ice during normal boiler operation, the temperature of the internal wall of the combustion product evacuation system, in all its length, has not to be below 0°C.

The flue must be installed in accordance with the recommendations of local and national codes of practice.

The flue pipe must be built using materials resistant to products of combustion, in Class W1, in accordance to EN 1443, in stainless steel or certified plastic. This can be PVDF (polyvinylidene fluoride) or PPS (Polyphenylene sulfide) or otherwise aluminium or different materials but with equivalent characteristics which comply to the regulations in force.

Instructions for the installer

Chimney dimension
DIN 4705

Flue Gas Temperature 40°C
Pressure available 40 Pa

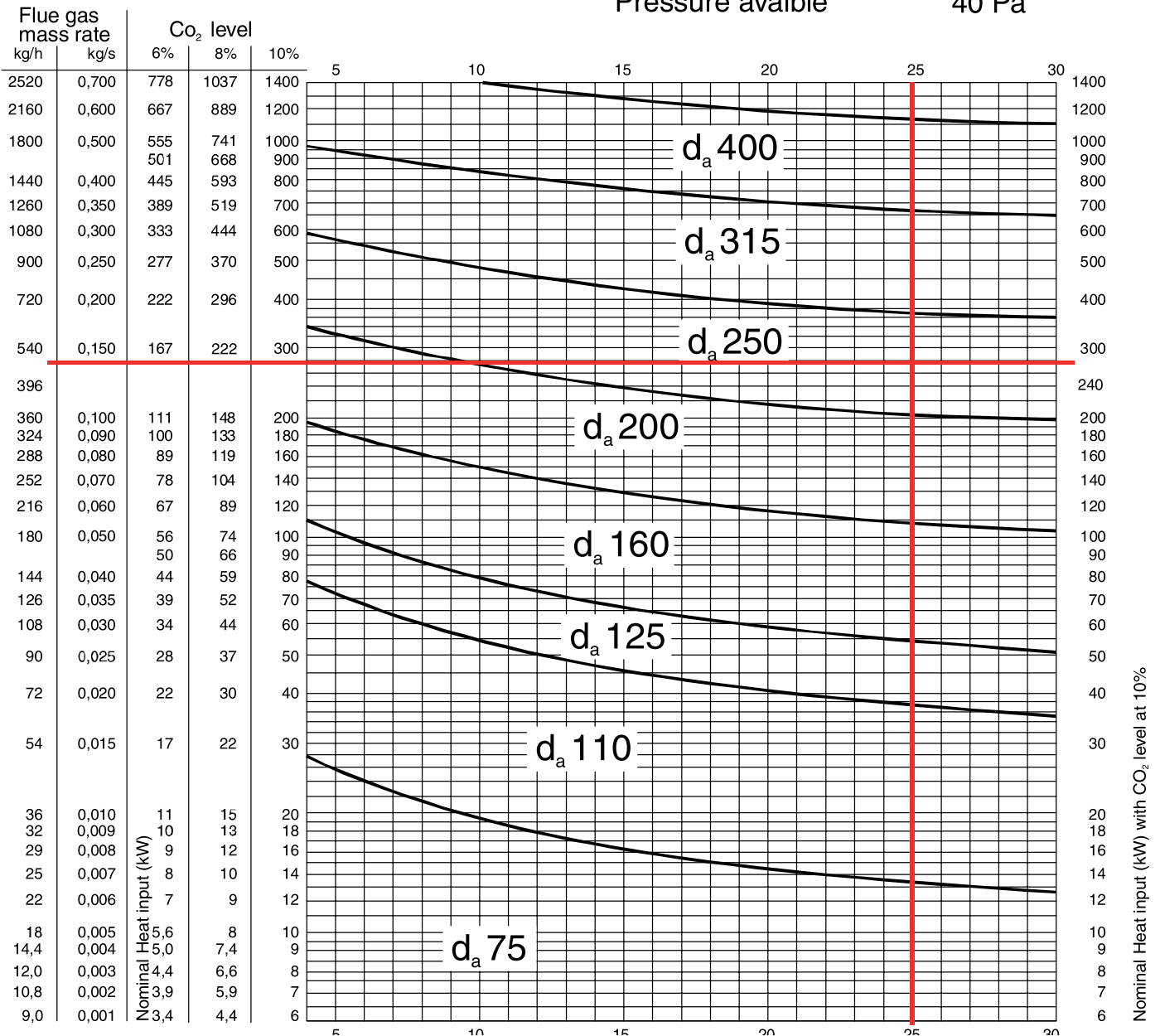

Flue gas mass flow rate	
WKM	Flue gas mass flow rate (max) kg/h
150	228,8
230	349,6
300	457,7
348	529,6

Esempio:
WKM 230
Flue gas mass flow rate = 349,6Kg/h
Chimney height = 25 m
Chimney connect. diam. = 200 mm



Note: The diagram shows indicative values

3.8 - CONDENSARE DRAIN

The condensate drain system must be:

- built in order to prevent the products of combustion discharging in the ambient or in the sewage(siphon);
- sized and built so as to permit the correct flow of the liquid discharges preventing any eventual leakages;
- installed in such a way to prevent the liquid contained inside freezing in cold weather
- The condensate, before being evacuated to the sewer, has to be neutralized, neutralisation which can be obtained by mixing the drain water coming from washing machines, dish washers etc., which normally have a base pH.

have an inclination toward the drain of at least 30 mm/m (3/8 in./ft). The liquid column inside the condensate siphon needs to be filled with water after installation. Its minimum height when all the fans are in operation must be at least 25 mm (1 in).

Given the acidity degree (pH 3 to 5) only plastic material can be used for the condensation evacuation pipes (special optional neutralization kits are available on request).

To maintain proper flow of condensate the drain pipe must

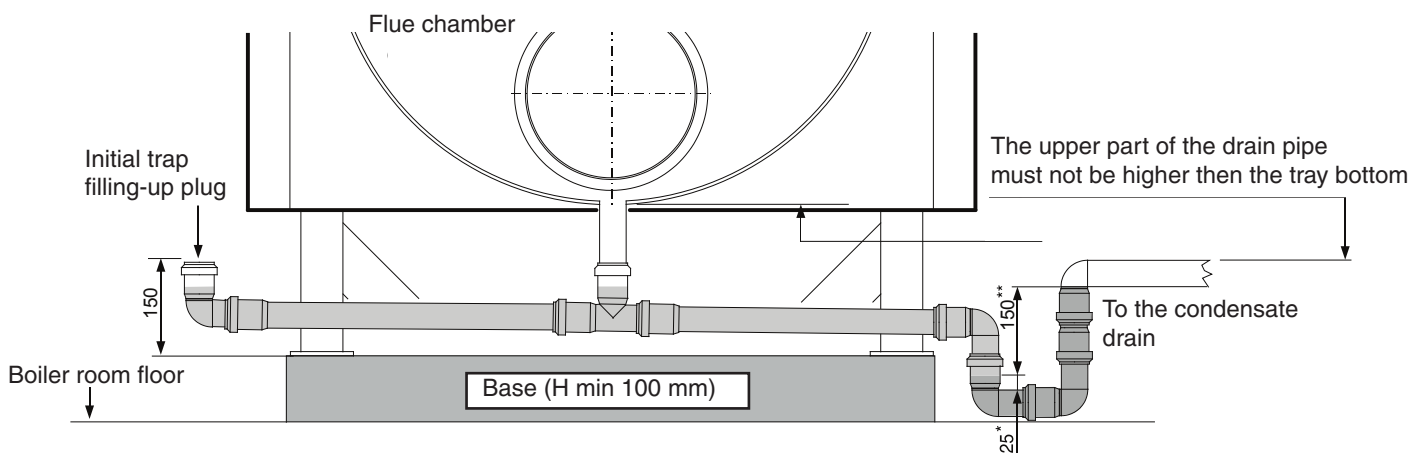

- * Minimum height safety siphon required by the Standard
- ** Minimum height with boiler running at maximum output

If the boiler is not installed on a plinth then it can be fitted directly onto the boiler floor and than a deep well of at least 100 mm will be required to house the siphon.

Any neutralization devices can be connected to the condensate after the trap.

For the calculation of the neutralization of the charge must be assessed the state of wear of the neutralizer after a year of operation.

Based on this information you can extrapolate the total duration of the charge.

For the neutralization of the condensate neutralizer kits are available NH 300 and NH 1500-P.

KIT NEUTRALIZATION NH 300 - code 00262827

- L 'NH neutralization unit 300 is designed to:
- Appliances with power up to 300 kW

- Works well with condensate drain the boiler placed lower down the condensate drain the boiler.

This unit does not require neutralization of the electrical connections.

KIT NEUTRALIZATION NH 1500-P - code 00262829

The 'unit of neutralizing NH 1500-P is designed to:

- Appliances with power up to 1500 kW
 - Works well with condensate drain the boiler placed higher condensate drain the boiler.
- This unit requires the neutralization of electrical connections.

Instructions for the installer

3.9 - FIRE DOOR: ADJUSTMENT, OPENING & CLOSING



IMPORTANT

- The door must be opened only when the boiler is cold to avoid causing damages to the fibre lining due to thermal stress.
- The door's fibre lining can crack after a brief period of boiler operation; this however does not reduce it's insulating capacity or it's life span.
- The door's fibre lining is easily replaceable and is covered by a 2 years guarantee.

For these models the door is assembled according to fig. 6. The door is therefore installed with two rotating hinges on the left hand side; the door is shut via 4 screws (position C).

The door mounting can be reversed so that it hinges from left to right.

Door adjustment:

- A) Axial door adjustment: further adjustment to the position of the door in relation to the chamber can be achieved through adjustment of the screws.

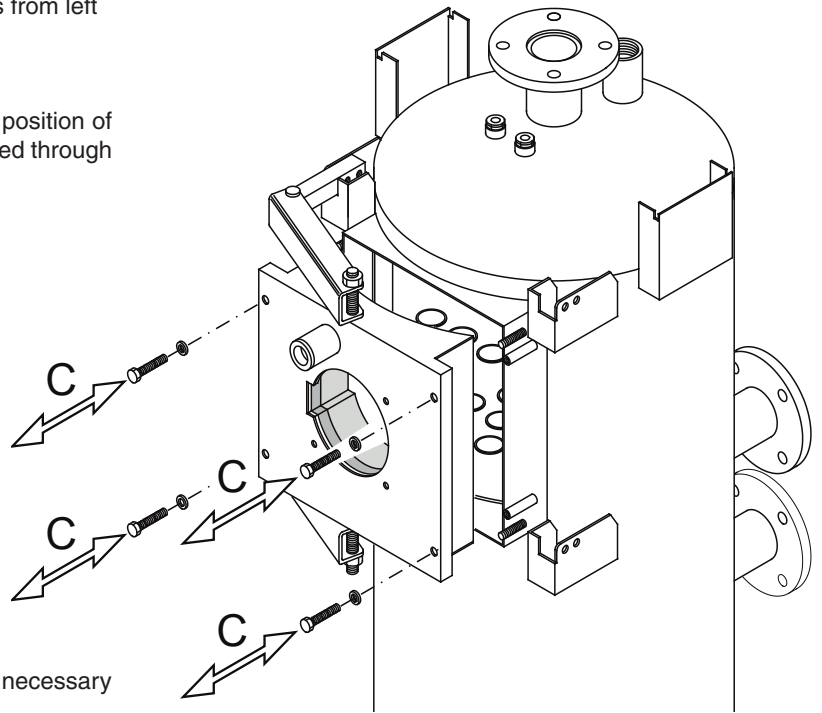

WARNING

Before opening the furnace door it is necessary to adopt the following precautions:

- Close the fuel cock (oil or gas) to the burner.
- Cool down the boiler by keeping the water circulating through it, and only then switch off the power.
- Place a Warning sign on the boiler with the following text: DO NOT USE , BOILER OUT OF ORDER, TO BE SERVICED.

3.10 - GAS CONENCTION



DANGER!

The gas connection must be carried out only by a qualified registered engineer who will have to respect and comply to the regulations in force and to the requirements indicated by the local gas supplier. An incorrect installation could cause injury to persons, animals or damage to property. The manufacturer shall not be held liable for any injury and/or damage.



Before installing the boiler it is recommended to thoroughly clean all the supply piping in order to remove any eventual residual grime which could compromise the boiler's correct functioning.



If you smell gas:

- a. Do not turn on or off electrical switches, use the telephone or any other object which can provoke sparks;
- b. Open all doors and windows in order to allow fresh air to enter and purify the room;
- c. Close all gas cocks
- d. Contact a service engineer, qualified installer or your gas supplier.



As a safety measure against gas leaks, the manufacturer recommends installing a surveillance and protective system composed of a gas leakage detector combined with an on-off selenoid valve fitted on the gas supply line.

The gas supply pipe must have a section which is adequate to the burner's output.

It is however important to comply with the specific standards and requirements in force.

Before commissioning an internal gas distribution system and therefore before connecting it to the gas meter, the complete installation must be tested for gas soundness.

If any part of the system is concealed from view the gas soundness test must be carried out before covering the pipes.

Before connecting the pipework the system must be tested with air or inert gas at a pressure of at least 100mbar.

Before commissioning the boiler ensure that the following operations are carried out:

- Open the gas meter cock and vent the air contained in the piping and subsequently proceed to vent device by device.
- Check, with the gas cock turned off, that there are no gas leaks. During the 2nd quarter of the hour from the start of the test, no pressure drop should be detected by the pressure gauge. Any gas leaks must be found by using only water soap solutions, or an equivalent product, and eliminated.
- Never look for gas leaks using a naked flame.

EXAMPLE OF A GAS SUPPLY SYSTEM

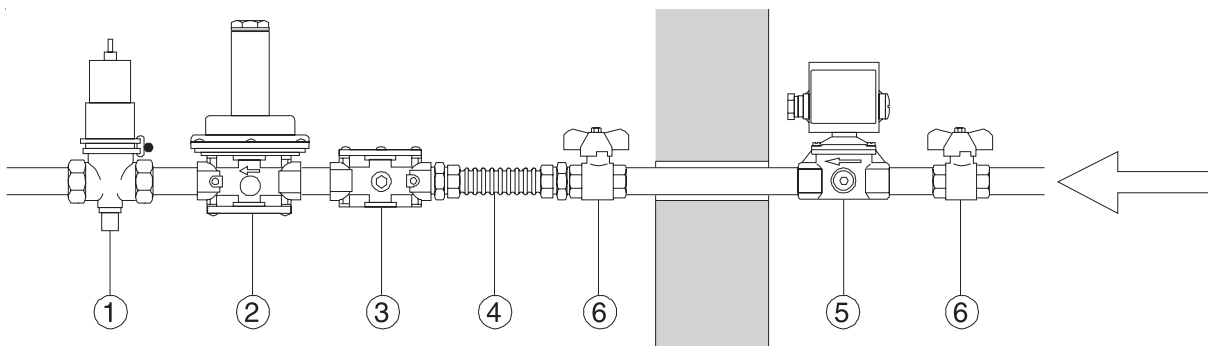

- 1 On-off gas supply valve
- 2 Double membrane regulator
- 3 Gas Filter

- 4 Anti-vibrating joint
- 5 Selenoid valve
- 6 On-off cock

3.11 - SYSTEM CONNECTION



WARNING!

Before connecting the boiler to the heating system we recommend that the system is flushed out with a suitable product in order to eliminate any metallic tooling or welding residues, oil and grime which could reach the boiler and affect the proper running of the boiler.

Do not use any solvents for flushing out the system as they could damage the system and/or its components.



Non-observance of these instructions could cause injury to persons, animals or damage to property. The manufacturer shall not be held liable for any such injury and/or damage.

The CH flow and return circuits have to be connected to the boiler via the respective connections as indicated on page 8.

When determining the size of the CH circuit pipes it is essential to bear in mind the pressure losses induced by any of the system's components and by the configuration of the system.

The route of the piping has to be conceived taking all the necessary precautions in order to avoid air locks and to facilitate the continuous purging of the system

Ensure yourself that the system's piping is not used as the earth clamps for the electrical or telephonic system. They are absolutely unsuitable for this use. In a short time this could cause serious damage to the piping, boiler and radiators.



WARNING!

IT IS ABSOLUTELY FORBIDDEN TO FIT ON-OFF VALVES ON THE BOILER BEFORE THE SAFETY DEVICES

CH pressure relief valve drainage

In correspondence to the CH pressure relief valve, provision should be made to install a discharge pipe with a funnel and a siphon which lead to an adequate drainage. The drainage has to be controllable by sight.



WARNING!

If this precaution is not taken it could lead to injury to persons, animals or damage to property. The manufacturer shall not be held liable for any such injury and/or damage

Expansion vessel connection



The PK...X 2S boilers are suitable for operating with a forced water circulation with an open or closed water tank. An expansion vessel is always needed because it compensates the increase in water volume caused by heating.

Filling /drainage connection



The boiler can be filled and drained by providing an appropriate external cock on the system's return pipe T5.

3.12 - DETERMINATION OF PRIMARY CIRCUIT PUMP OR BOILER SYSTEM PUMP

The boiler pump must have a delivery head which can ensure the water flow rate as shown in the graph "Water pressure losses".

The following table gives an indication of the pump's flow rate in function of the Δt of the primary circuit.



The size of the pumps must be determined by installers or technical engineers according to boiler data and system design. The water side resistance curve of the boiler is shown in the following graph.

The pump is not an integral part of the boiler. We recommend you choose a pump with the rate and discharge head at about 2/3 of its characteristic curve.

Power supply in kW	150	230	300	348
Max flow rate demanded in l/h ($\Delta t=15K$)	7826	11992	15708	18213
Niminal flow rate requested in l/h ($\Delta t=20K$)	5870	8994	11781	13660

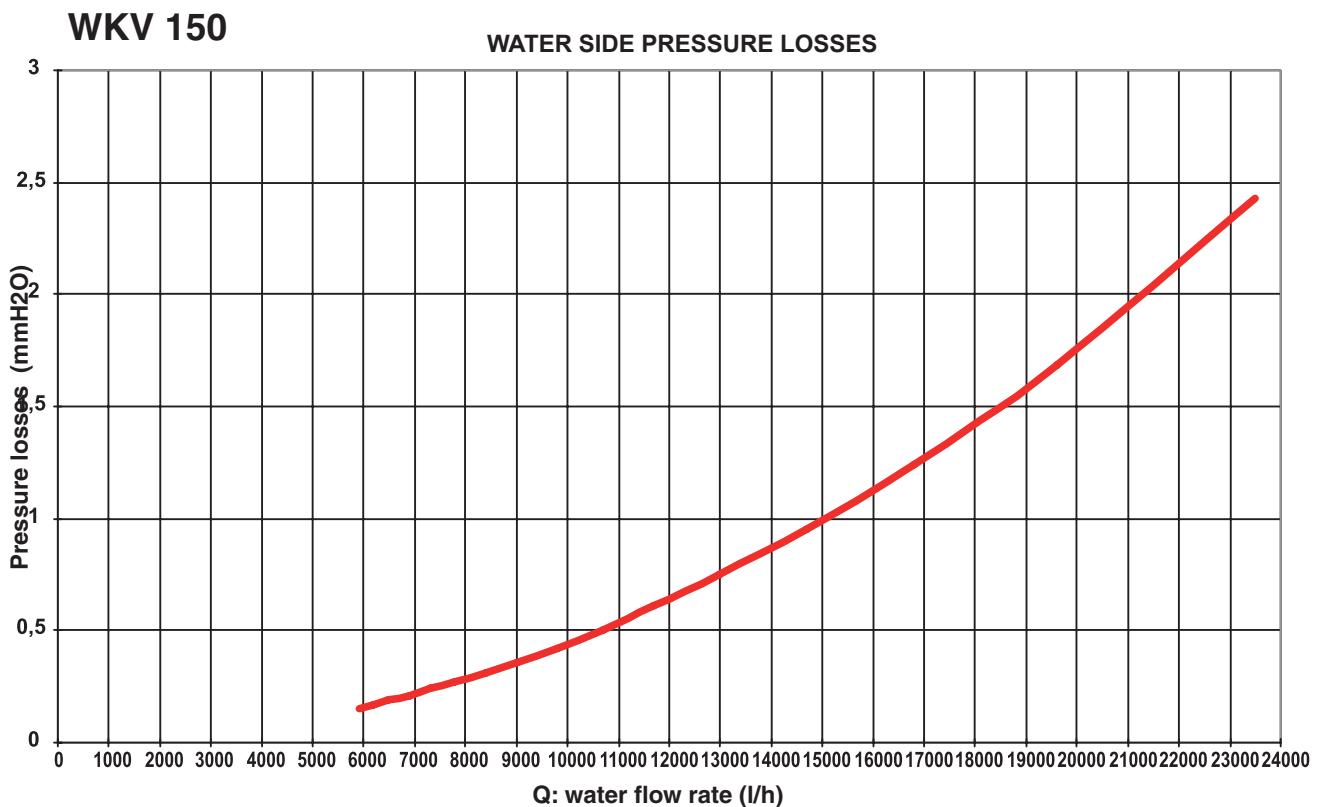

Instructions for the installer

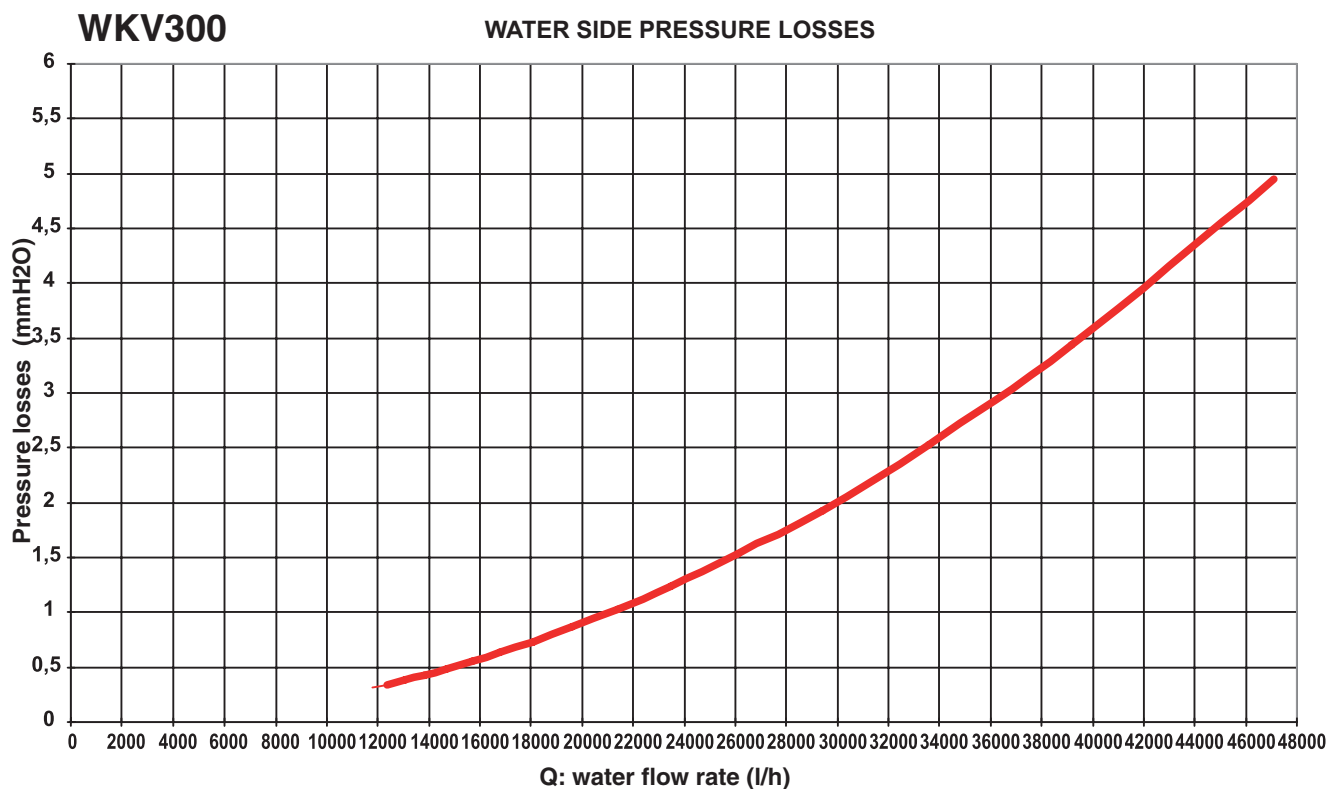
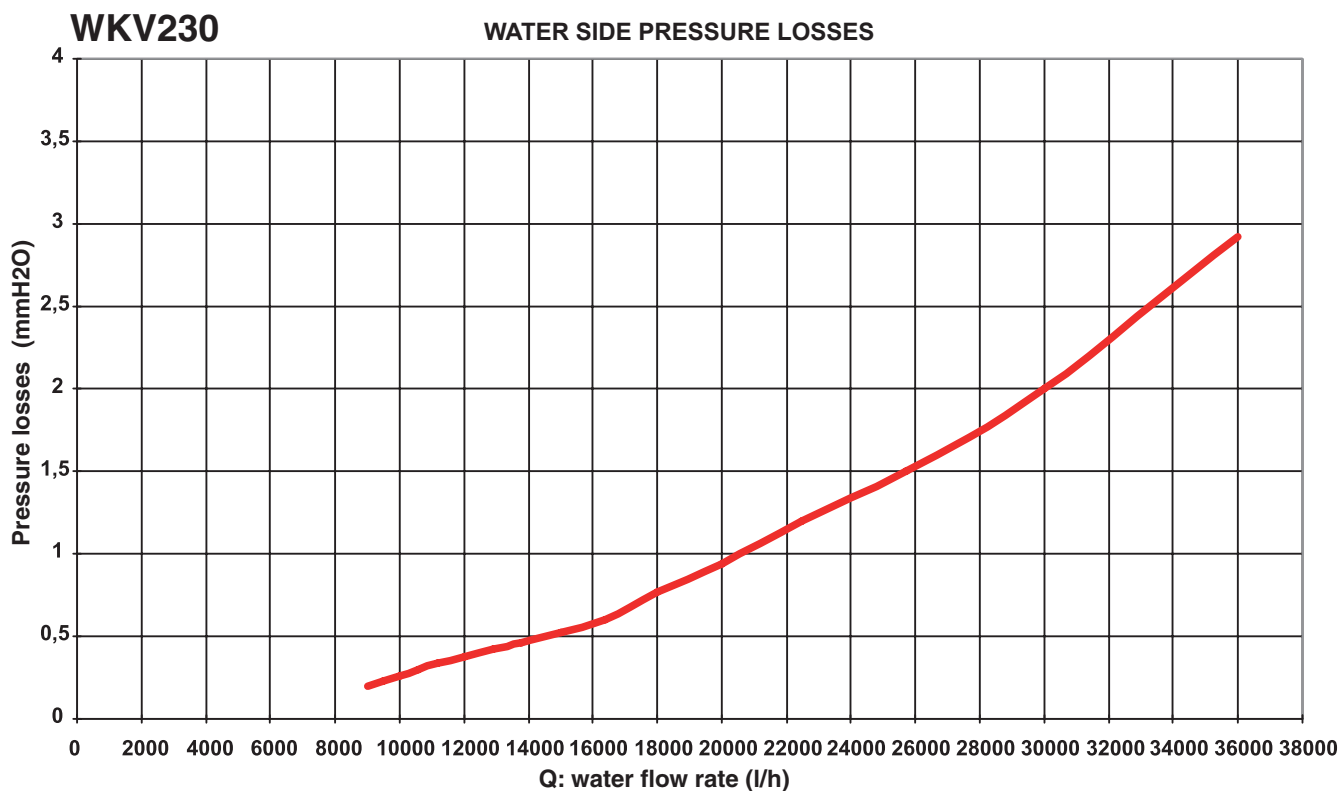

WKV348

WATER SIDE PRESSURE LOSSES

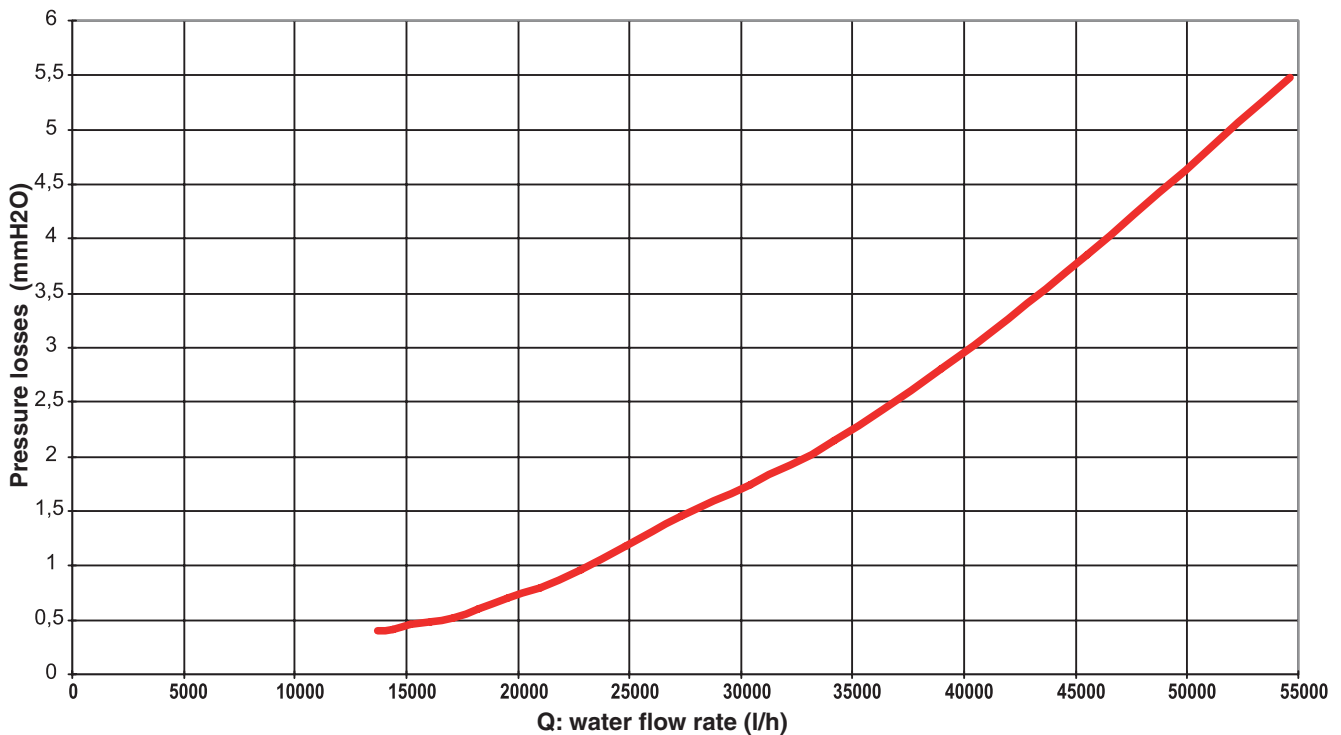

3.13 - FROST PROTECTION

If the flow temperature (measured at global flow NTC) falls below 7°C, the system pump circulates water around the water circuit and all the heat modules will operate at minimum output.

Note: The anti-freeze solution must be compatible with the materials used on the entire heating system and tolerable with aluminium alloys.



WARNING:

If the boiler has remained unused for a long period, and you notice the presence of frost (temperatures of < 3°C), do NOT fire the boiler. Fire the boiler only if you know that an anti-freeze solution has been added in the proper percentage to the primary circuit.

3.14 - MIXING HEADER AND PLATE HEAT EXCHANGER

In order to ensure correct boiler operation it is necessary to use a mixing header which guarantees:

- the separation and collection of circuit dirt
- optimal air venting
- hydraulic de-coupling of the two hydraulic circulation circuits
- balancing of the circuits

A suitably sized plate heat exchanger has the advantage of separating the two circuits (primary and secondary), permitting the installation of the boiler in an industrial design.

Instructions for the installer

3.15 - WATER TREATMENT

The chemical-physical characteristics of the filling water and reinstatement water in heating systems are of fundamental importance for guaranteeing correct and safe boiler operation.

Before filling the CH circuit with water, it is necessary to analyse the water and decide for a proper treatment.

The purpose of this treatment is finalized to eliminate or substantially reduce the following problems:

- lime scale deposit
- corrosions
- deposits
- biological growths (moulds, bacteria, algae, fungi, etc)

The chemical treatment of the network water enables the prevention of these problems and guarantees safe boiler operation and economical advantages, in terms of maintenance and global thermal efficiency.

The chemical analysis of the water enables us to obtain a lot of information on the system's condition and state of "health".

It is essential to avoid any problems with the boiler.

The pH is a measure of the acidity or alkalinity of a solution.

The pH scale has a range of 0-14, where 7 is neutral.

Values inferior to 7 indicate acidity, values above 7 indicate alkalinity.

The ideal pH value for water in heating systems fitted with aluminium boilers is between 6,5 and 8, with a hardness of 15°F.

In heating systems where the water has a value outside this range, this considerably accelerates the destruction of the protective oxidized layer which naturally develops inside the aluminium bodies: if the pH is below 6, acidity is present, if it is above 8, the water is alkaline or it is caused by an alkaline treatment (for example phosphate or glycol used as an antifreeze) or in several cases it is due to the natural formation of alkaline in the system.

Vice versa, if the pH value is between 6,5 and 8, the aluminium surfaces of the boiler body are passivated and protected from further corrosive attacks.

To minimize corrosion it is essential to use a scale inhibitor, however in order for this to function correctly, the metallic surfaces have to be clean.

The best corrosion inhibitors on sale also contain a protective system for aluminium which acts by stabilizing the water's pH value, preventing unforeseen variations.

We recommend that the heating system's water pH value is systematically controlled (minimum twice a year). In order to do this, it is not necessary to run a chemical analysis in a laboratory, but it is sufficient to use a simple analytical 'kit' contained in portable cases, easily found on sale.

Therefore, prior to filling the heating system with water it will be necessary to fit the devices indicated in the figure below.



THE CONNECTION MUST BE FITTED ON THE PRIMARY CIRCUIT'S RETURN PIPE DOWN-STREAM OF THE CIRCULATING PUMP

All the necessary precautions must be taken in order to avoid the formation and localization of oxygen in the system's water. For this reason, the plastic pipes used in underfloor heating systems must be impermeable to oxygen.

If any antifreeze solutions are used ensure yourself that they are compatible with aluminium and with any other components and materials fitted on the system.



**WARNING!
ANY DAMAGE CAUSED BY THE BOILER,
DUE TO THE FORMATION OF LIME SCALE
OR DUE TO CORROSIVE WATER WILL INVA-
LIDATE THE APPLIANCE WARRANTY.**

EXAMPLE OF SCALE REDUCING DEVICE CONNECTION FOR WATER TREATMENT

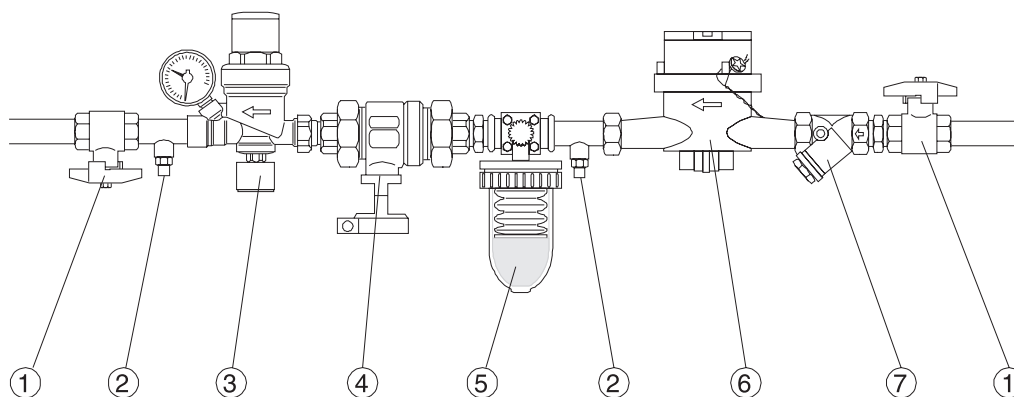

1. Ball valve
2. Inspection pocket
3. Filling-up group
4. Disconnecter
5. Scale reducing device
6. Litrecounter (recommended)
7. "Y" filter

3.16 - CASING ASSEMBLY (With panel on the right side)

- A. Fit the insulation blanket (1) onto the boiler shell and secure in to place using the elasticated straps (2) provided, ensuring that the metal clips grip in to the external surface of the insulation.
- B. Fit the boiler shells top insulation blanket (3) and secure in to place using the elasticated straps (2) provided, ensuring that the metal clips grip in to the external surface of the boiler shell's insulation.

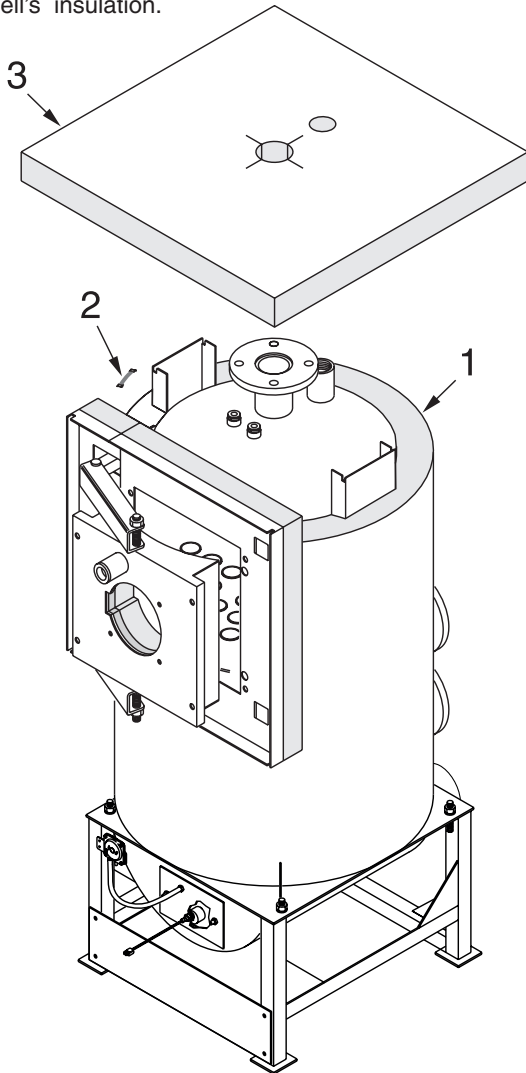

Make a convenient cut in the upper part of the insulation blanket to get easy access to the bulb holders

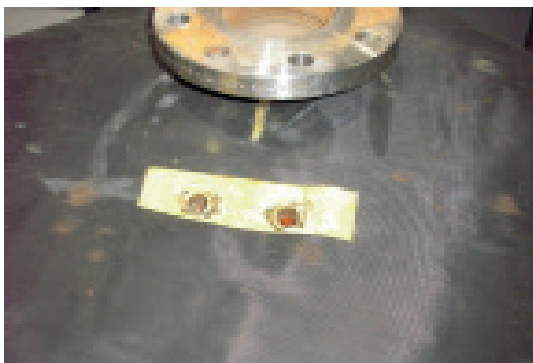

- C. Fit the self-tapping screws onto the internal profiles of the 2 side panels (4 and 5).

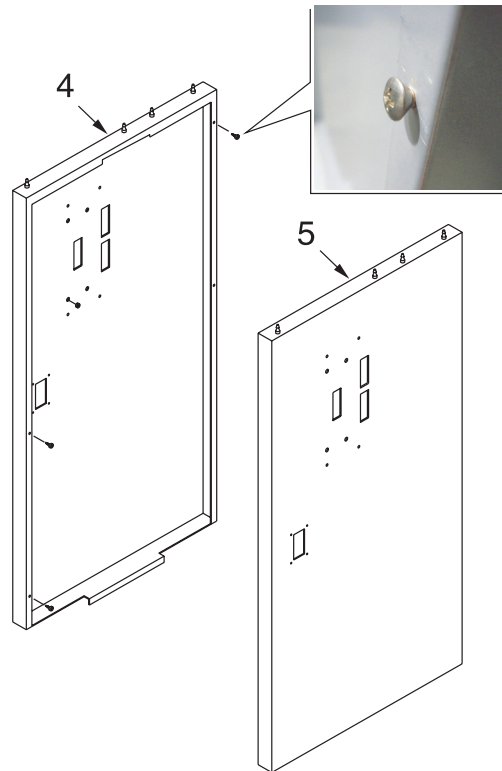

- D. Fit the left side panel (4) fixing it on to the front panel and securing it to the top left squadretta on the boiler shell, inserting the lower bend inside the bottom L profiles.

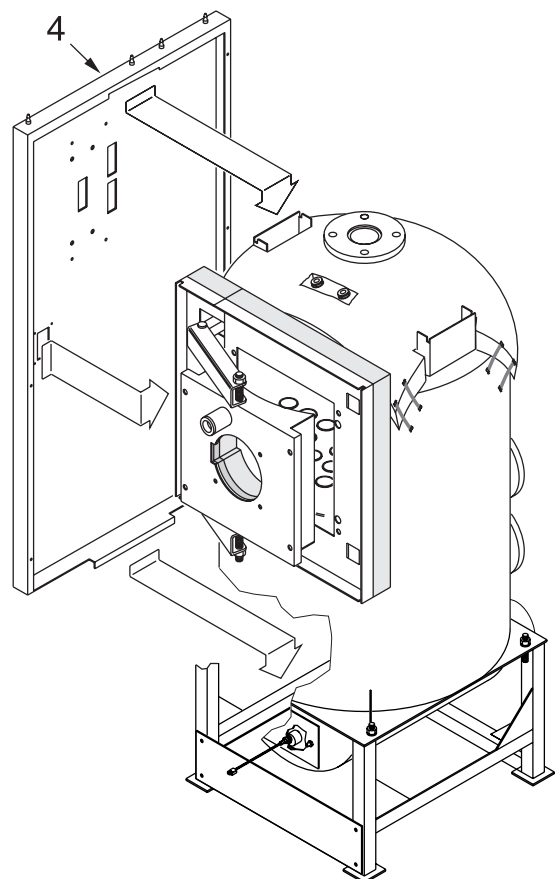

Instructions for the installer

E. After removal of the two side screws from the control panel rotate its cover towards the front

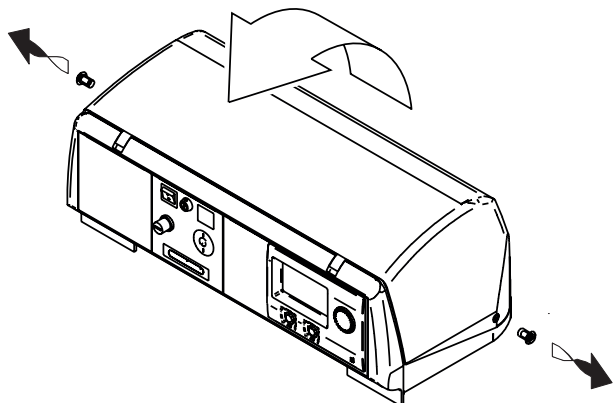

and insert the cables and the capillaries of thermometer and thermostats through the slots on its base.

F. Fit the right hand side panel (5) to the lower panel and fix it to the upper squadretta on the right hand side of the boiler body, inserting the lower bend inside the bottom L profiles.

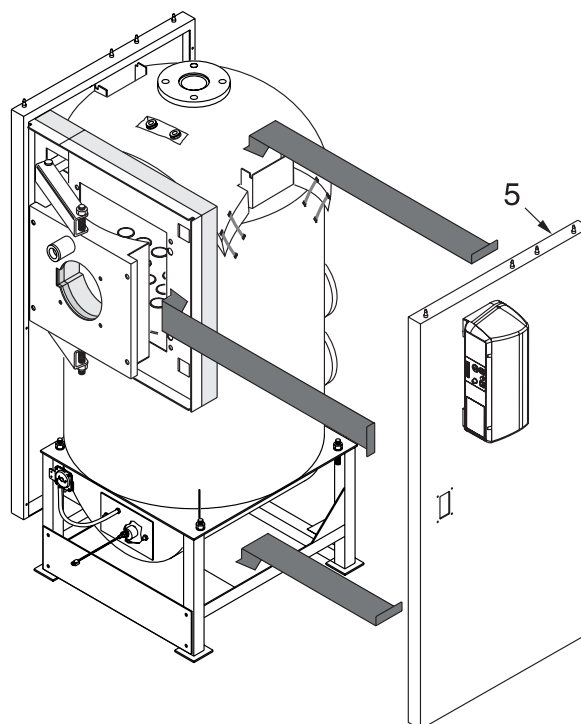

G. Insert the thermometer and thermostat bulbs in the sensor pockets as shown in Fig. 8

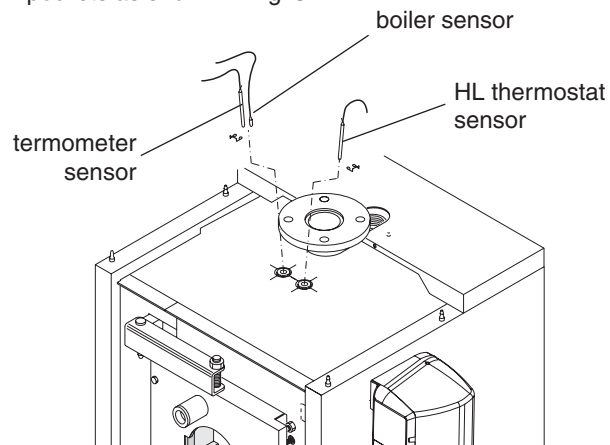

Fit the control panel to the right hand side panel (5).



and connect the mains, the burner, the pump(s) and any equipment to the control panel.

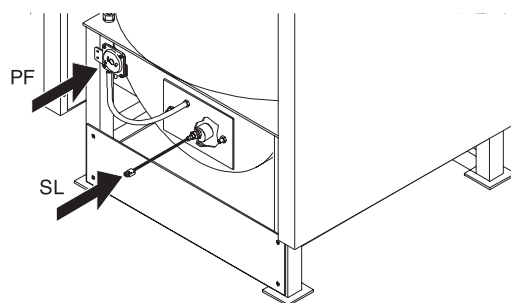

Instructions for the installer

Guide the burner plug through the side cable clamp plate(6) and clamp the cable using the cable clamp supplied. Fix the side cable clamp plates to the casing side panels.



Refit the upper shell of the control panel.

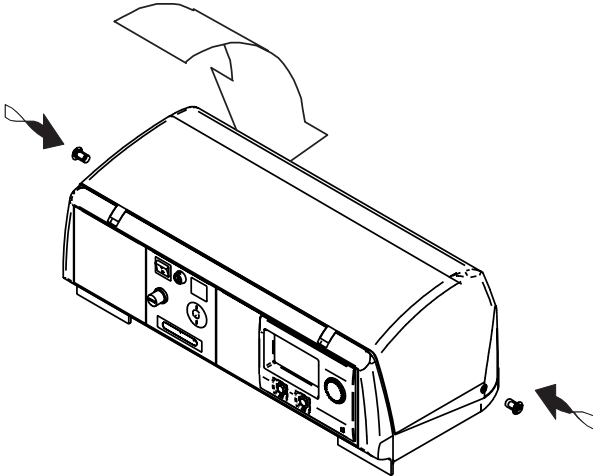

Fix the platelets (pos 6) support the two sides of the conduit and the plate (pos 7) closing the lateral left side.

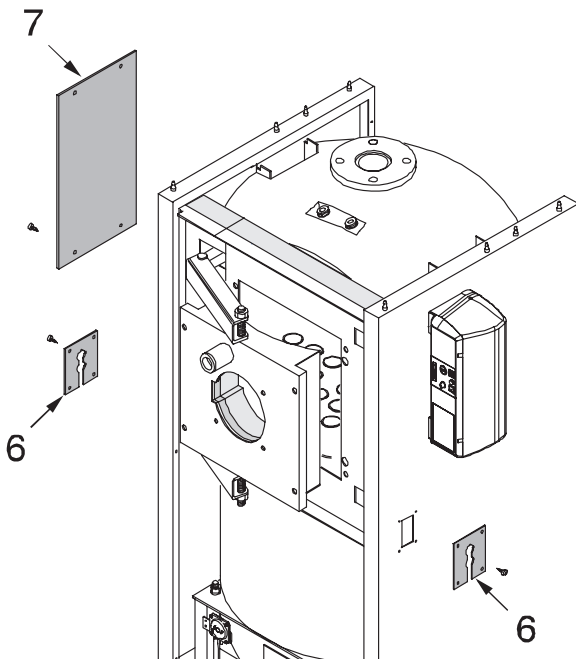

H. Fit the top panel (8) and fix it onto the side panels (4 & 5).

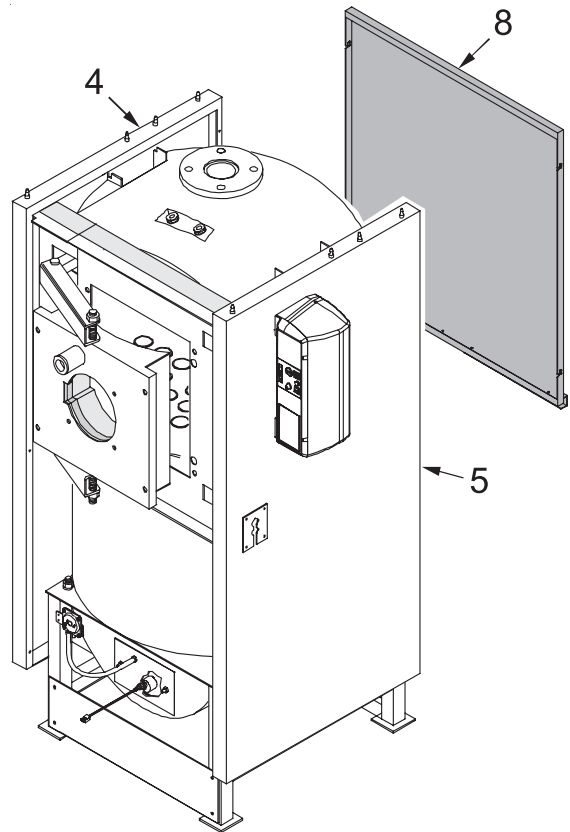

I. Fix the retaining strips (9) onto the lower left hand side rear panel (4) and to the upper panel (8).

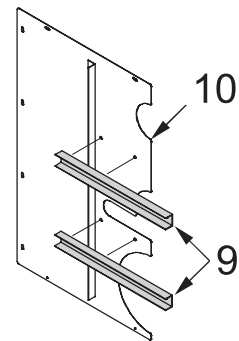

L. Fit the right hand side rear panel (10) onto the left hand side rear panel (4) and to the upper rear panel (8).

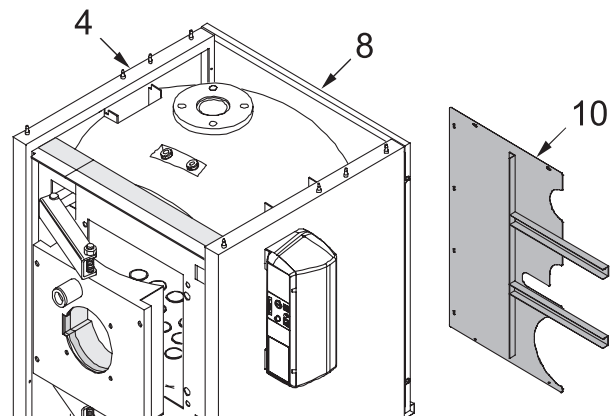

Instructions for the installer

- M. Fit the lower right hand side rear panel (11) onto the right hand side rear panel (5), to the left hand side rear panel (10) and to the upper rear panel (8).
Unite the two rear panels with the retaining strips profile (12).

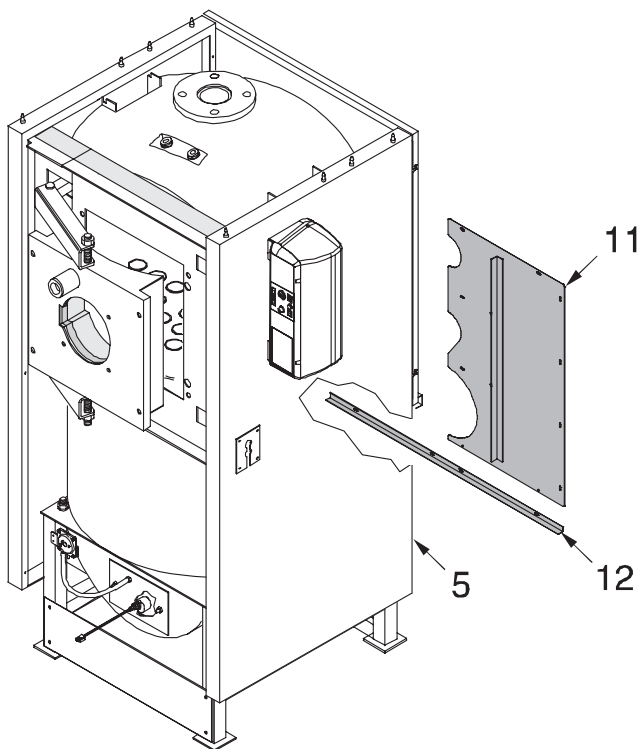

- N. Fit the lower front panel (13) and fix it on to the side panels (4 and 5).

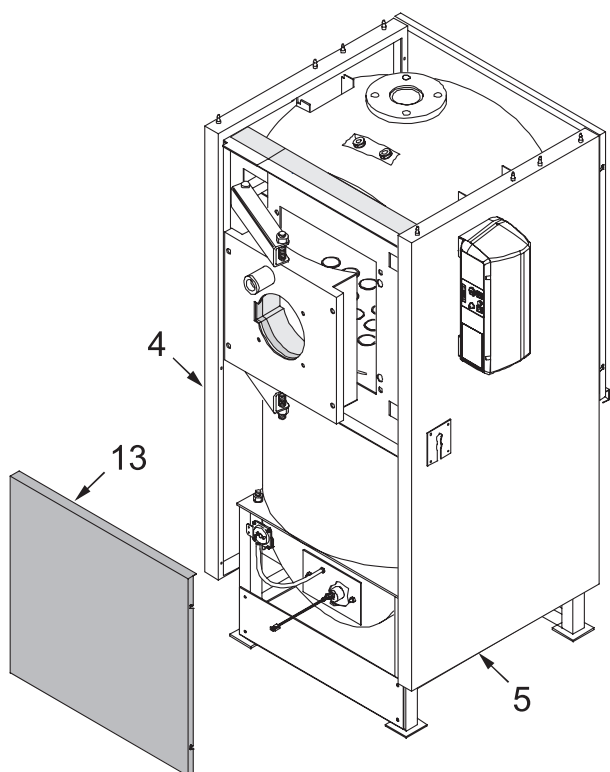

- O. Position the top panels (14 and 15) and press them against the side panels.

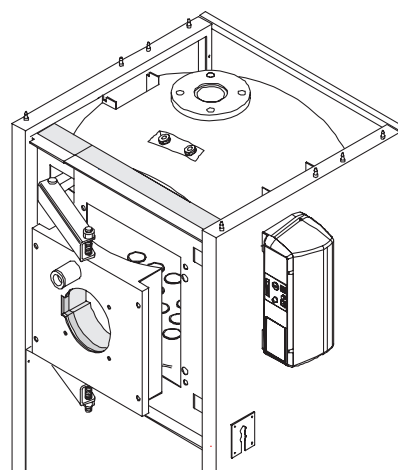
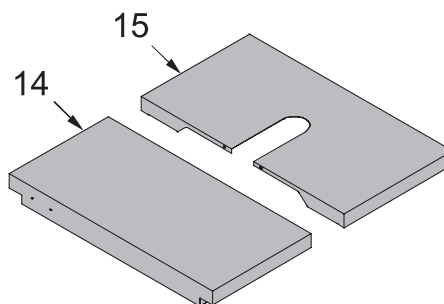

fit them on to the side panel.
The data plates are in the plastic bag containing the documents.

Montaggio del pannello comandi sul lato sinistro



Warning!

In the event that the panel is mounted on the left side, you must turn the temperature control unit eBus.

To turn the temperature control unit eBus on the control panel, you must:

- Q) remove the two screws "1" cover fixing "2" access to the terminal unit of the "3",

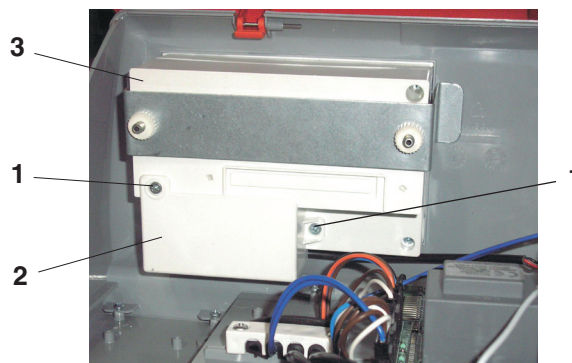

Instructions for the installer

R) after removing the cover disconnect the connector "4", unscrew the 2 nuts "5" and remove the bracket "6",

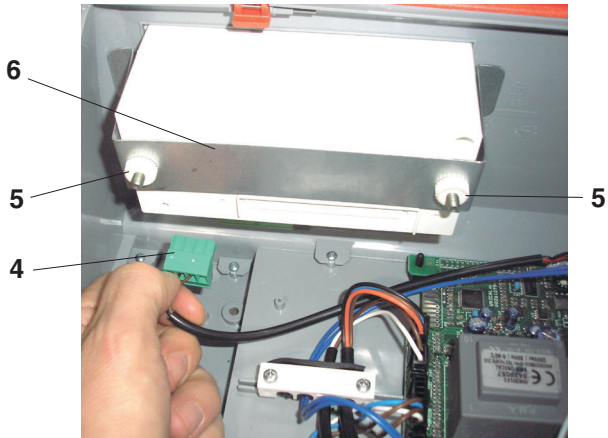

U) plug the connector "4" on the unit,

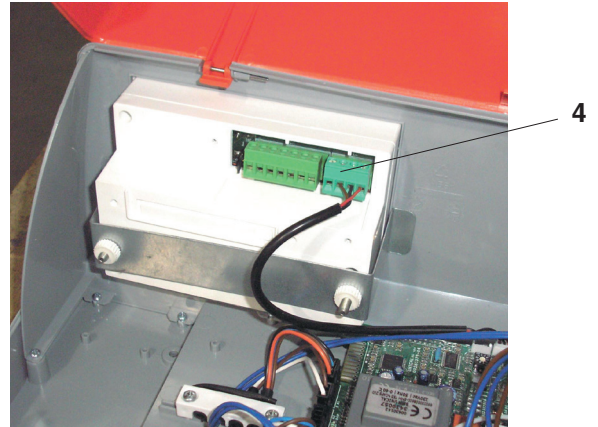

S) Turn the Unit 180°,

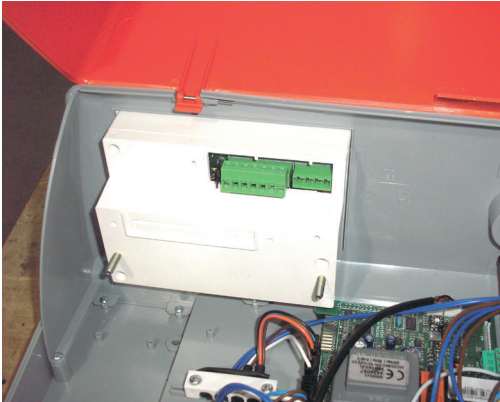

V) replace the cover "2" access to the terminal unit, and secure with the two screws "1".

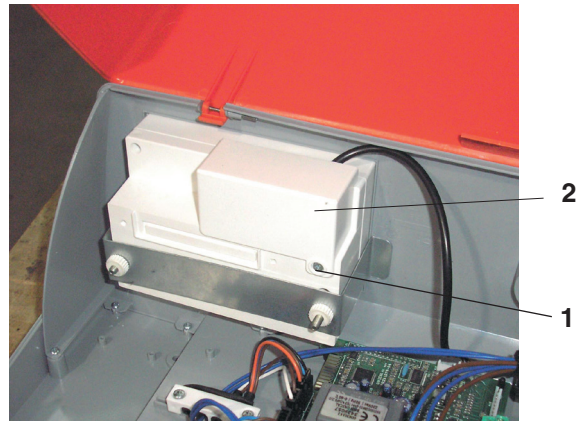

T) to reposition the unit "3", through the bracket "6" and tighten the 2 nuts "5",

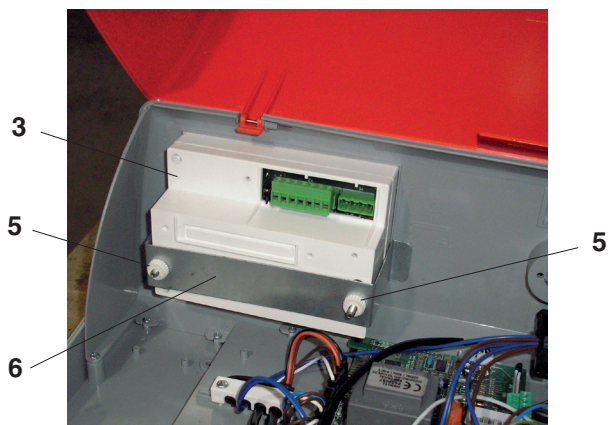

Instructions for the installer

3.17 - SYSTEM FILLING AND DRAINING



Warning!
Do not mix the CH system's water with anti-freeze or anti-corrosion solutions using wrong concentrations! It could cause damage to the washers and could provoke noise during normal boiler operation.
The manufacturer refuses all liability for injury to persons, animals or damage to property deriving from not having respected the above mentioned recommendations.

To fill the system it is necessary to fit a filling cock on the system's return.

The boiler is equipped with its own drain tap, whose position is indicated in the figure on page 17.
This tap must NEVER be used for draining of the whole system as this could lead to system dirt gathering in the boiler, compromising good boiler operation. Therefore, the system has to be fitted with its own draining tap, of the right size for the system's capacity.

After completing all the system's service connections the circuits may be filled.

EXAMPLE OF FILLING MANIFOLED

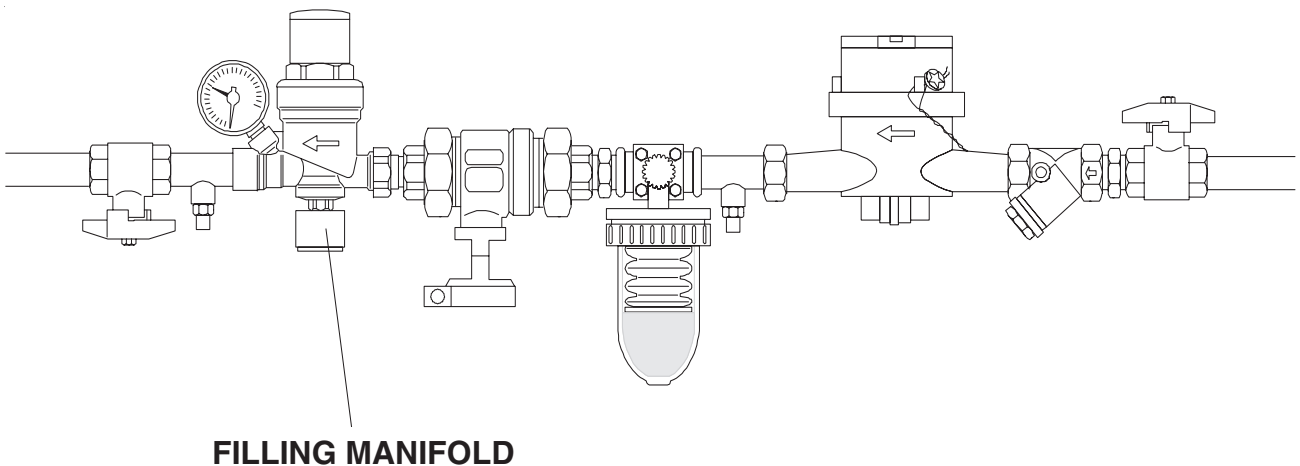

3.18 - ELECTRICAL CONNECTIONS

General warnings

The electrical safety of the appliance is assured only when it is correctly earthed, according to the electrical rules in force. The gas, D.H.W. and the CH system pipes cannot be used as ground plates.

Ensure that the above safety electrical requirements subsist; in case of doubt, ask for a professionally qualified technician to check the appliance's electrical system.

The manufacturer refuses responsibility for any damages arising from failure to earth the boiler correctly.

It is necessary that a qualified technician verifies that the electrical system is adequate to the appliance's maximum absorbed power, indicated on the data plate, verifying in particular that the section of the system's cables is suitable to the appliance's maximum absorbed power.

For the appliance's general electrical supply the use of adaptors, multiple sockets and/or extension cords is strictly forbidden.

The use of any power supplied equipment implies the observance of several fundamental rules, such as:

- Do not touch the appliance with any wet part of your body and/or barefooted;
- Do not pull the supply cables
- Do not expose the boiler to sunlight, rain, etc., unless it is explicitly foreseen;
- Do not permit children or inexperienced people to use the appliance.

Mains electrical supply connection 230V

The electric connections of the boiler are shown in the section named "ACTUAL WIRING DIAGRAM" (paragraph 3.19 page 31)

The boiler installation requires a mains supply of 230 V - 50 Hz. The wiring to the boiler must conform to current CEI regulations.

The supply cable must have the following characteristics: PVC HT CABLE H05V2V2-F 3x0,75



DANGER!

The electrical connections must be carried out only by a qualified engineer. Before carrying out the connections or any other operation on the electrical parts, always switch off and disconnect the electricity supply and ensure yourself that it cannot be accidentally turned on. It is necessary to fit a double pole switch on the electrical supply line, having a 3 mm contact



separation in both poles, in an easy accessible position in order to make quick and safe the servicing operations.



The supply cable must be replaced only by highly qualified personnel. Failure to do so could compromise the appliance's safety.



WARNING!

We remind you that upstream of the electrical connection, it will be necessary to foresee a service relay (NOT SUPPLIED) which, when the electrical safety devices (ISPESL) intervene, shuts down the electrical supply to the on-off fuel valve fitted on the gas supply circuit, but not to the boiler so as to guarantee the running of the pump and permit the boiler to cool down.

Room thermostat connection



DANGER!

Switch off and disconnect the electricity supply before carrying out any operations on the electrical parts.

- Gain access to the Y1 terminal board
- Room thermostat: connect the thermostat's cables to the terminals 1 and 2.

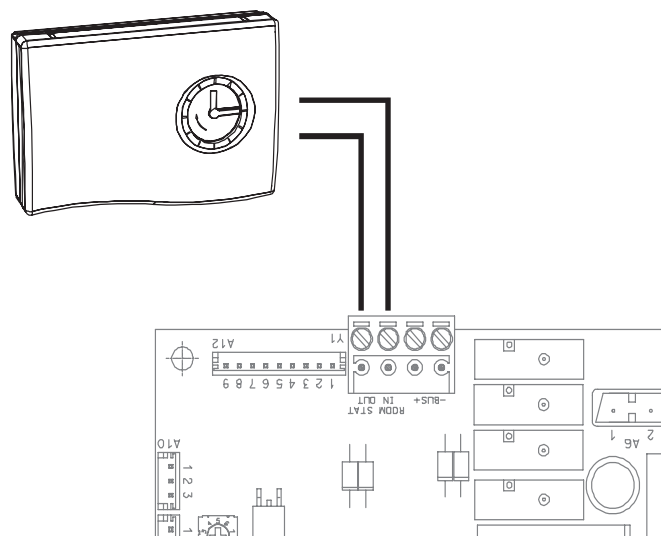

Instructions for the installer

Outdoor sensor connection Single boiler



DANGER!
Switch off and disconnect the electricity supply before carrying out any operations on the electrical parts.

- Gain access to the rear of the eBus and remove the terminals numbered from 5 to 11.
- Outdoor sensor connection: insert the cables between the pins 9 and 10 on the e-Bus terminal board.

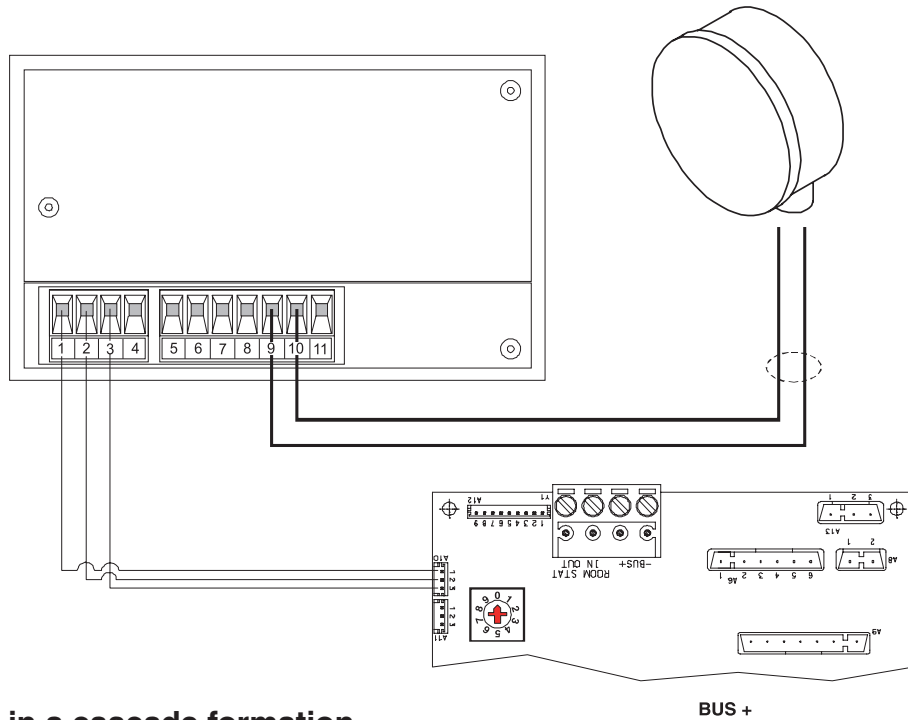

Boilers installed in a cascade formation



DANGER!
Switch off and disconnect the electricity supply before carrying out any operations on the electrical parts.

- Gain access to the Y2 terminal board on the BCM Cascade controller
- Outdoor sensor connection: insert the cables between the pins 6 and 7 on the terminal board.

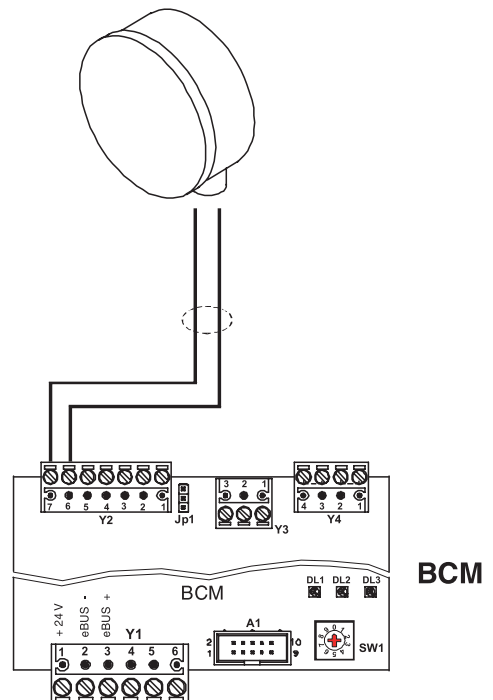

Instructions for the installer

3.19- FUNCTIONAL FLOW WIRING DIAGRAM

- E.ACC = Ignition electrode
- E.RIV = Ionization electrode
- IG = Main switch
- PF = Flue switch
- PG = Gas switch
- SR = CH sensor
- SRR = CH return sensor
- SL = Condensate level sensor
- TL = Limit thermostat
- TR.ACC = Ignition transformer
- VG = Gas valve
- VM = Modulating fan detection/adjustment

eBUS HEATING CONTROL (If foreseen)

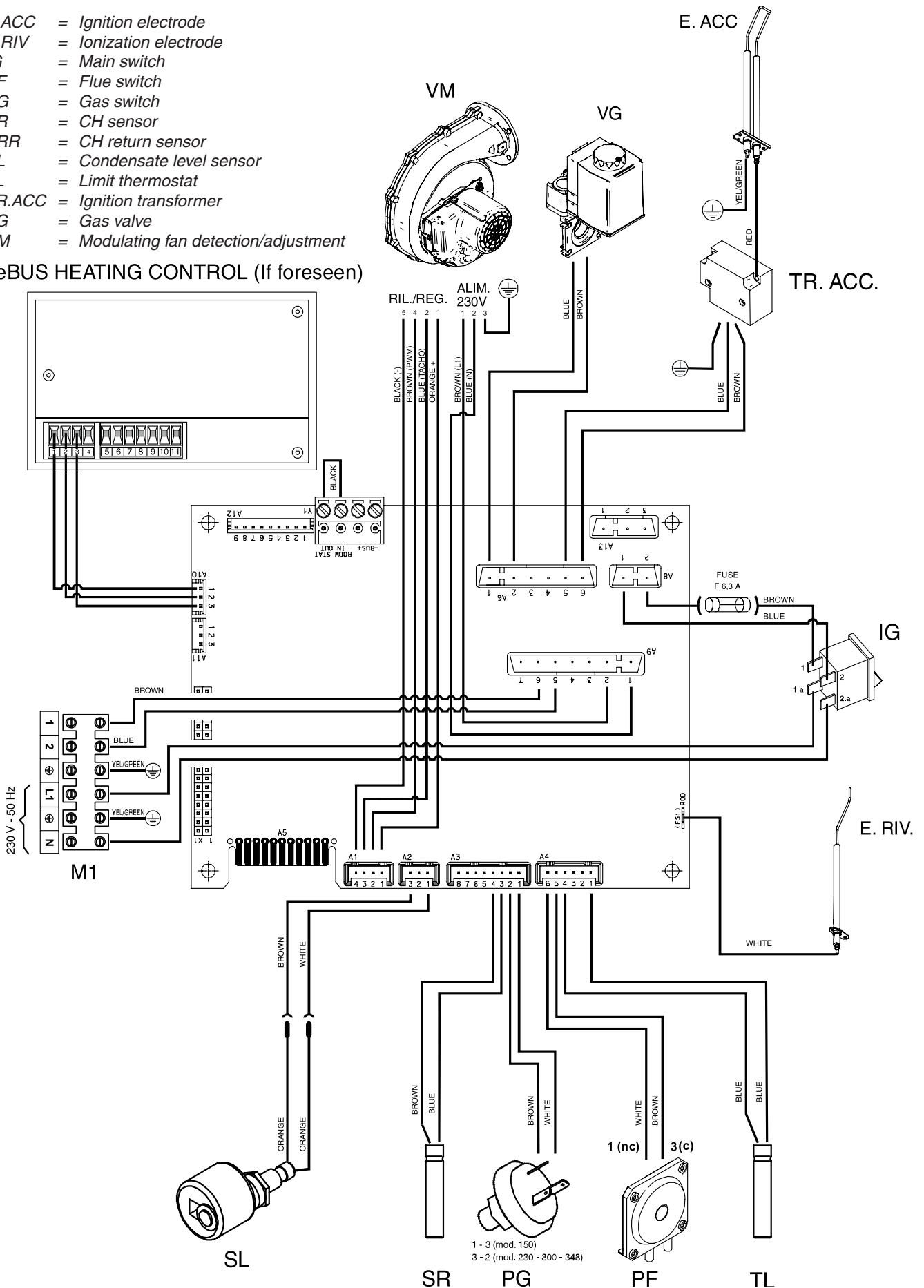

3.20 - TYPES OF INSTALLATION

Single boiler

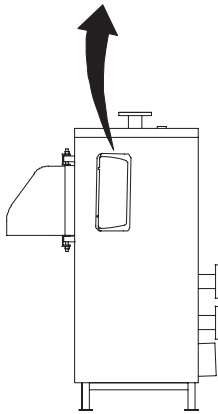
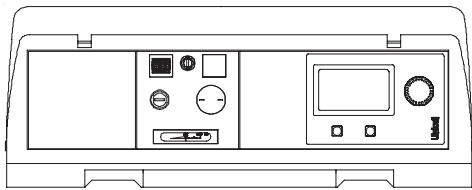

Control panel fitted with an eBus heating controller

Boiler Cascade

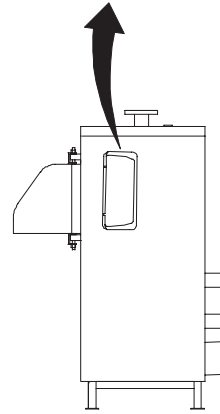
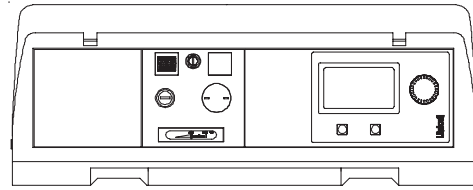

Control panel fitted with an eBus heating controller

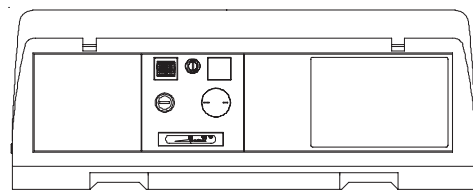

Slave Panel

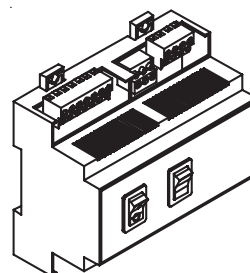
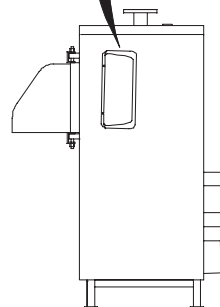

BCM cascade manager (kit 00361602)

Instructions for the installer

Electrical connections for boilers installed in a cascade formation



The cable for the connection between the boiler and the BCM must have the following characteristics:
PVC HT CABLE 3x0,5

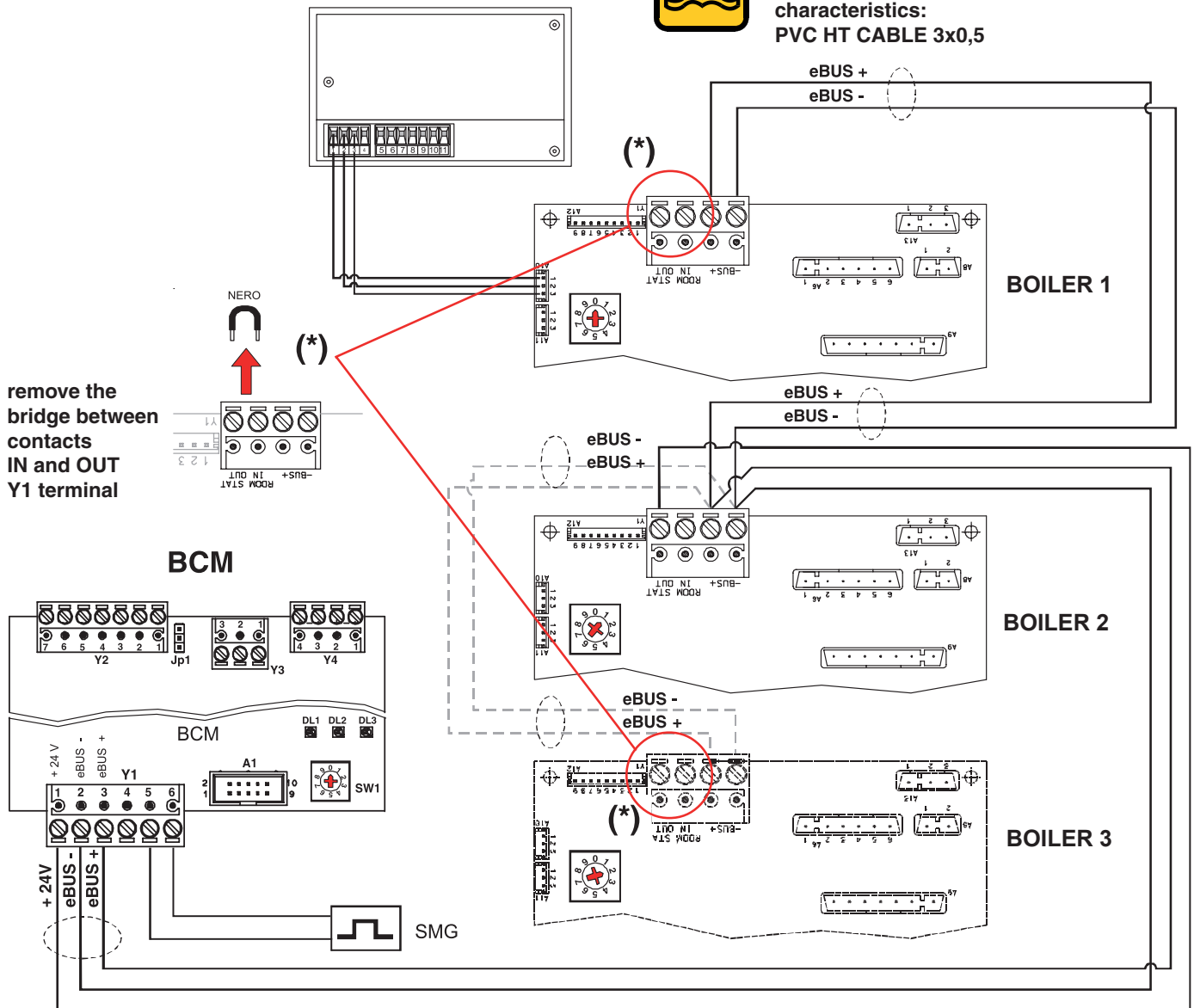

Board selector setting



pos.	BCM
Boiler 1 (with eBus UNIT)	0
Boiler 2 (Slave)	1
Boiler 3 (Slave)	2
Boiler 4 (Slave)	3
Boiler 5 (Slave)	4
Boiler 6 (Slave)	5
Boiler 7 (Slave)	6
Boiler 8 (Slave)	7

3.21 - INSTALLATION EXAMPLES (Functional diagram)

Boiler connection to the heating system, with 1 direct high temperature heating zone

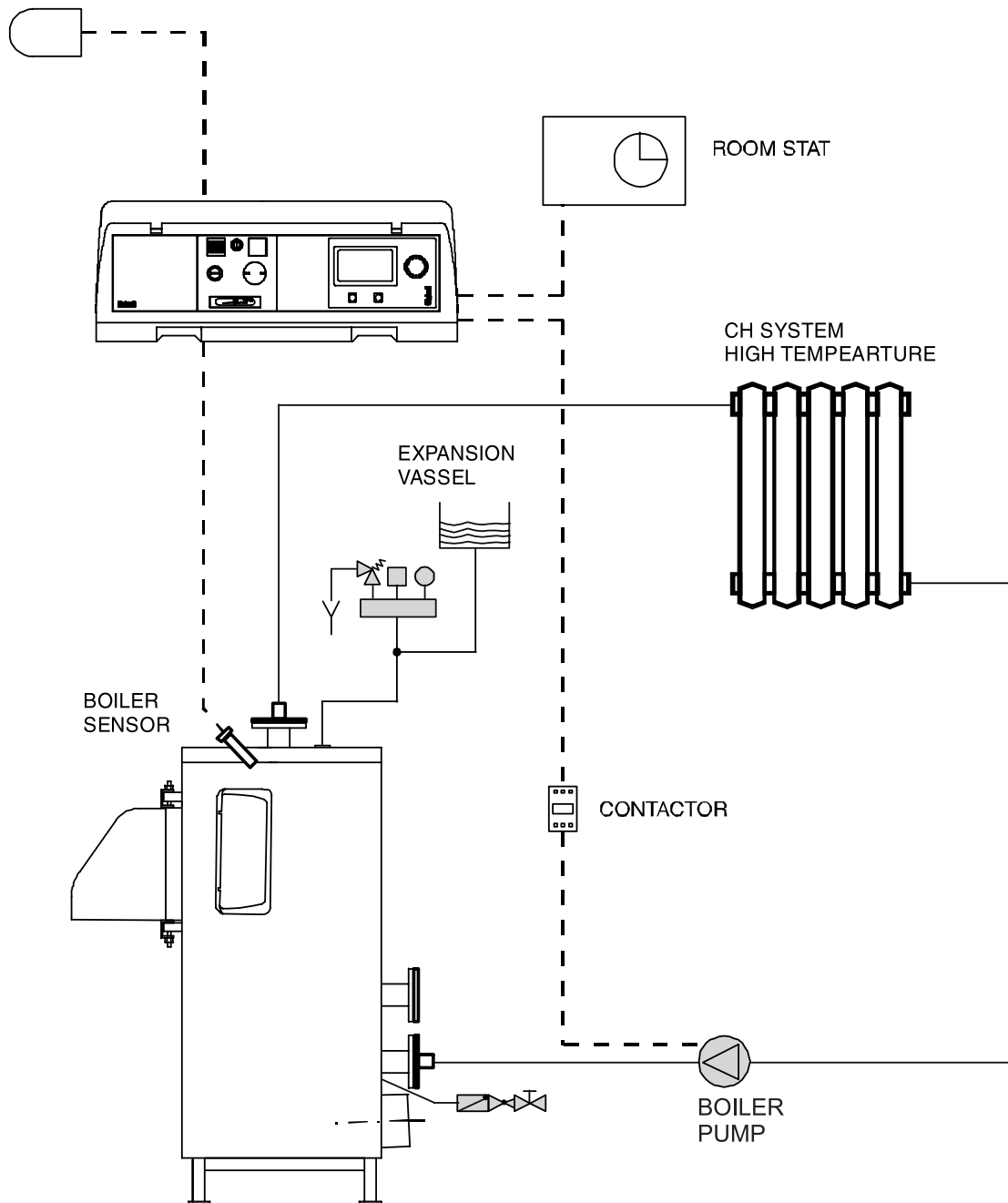

NB: In case of a single system return (low or medium temperature), the connection must **ALWAYS** be carried out on the inlet and the lower back of the boiler (stub "low-temperature system return").

Installation of 2 boilers in a cascade arrangement functioning for 1 high temperature zone + 1 low temperature zone, managed via a motorized mixing valve + domestic hot water production.

Instructions for the installer

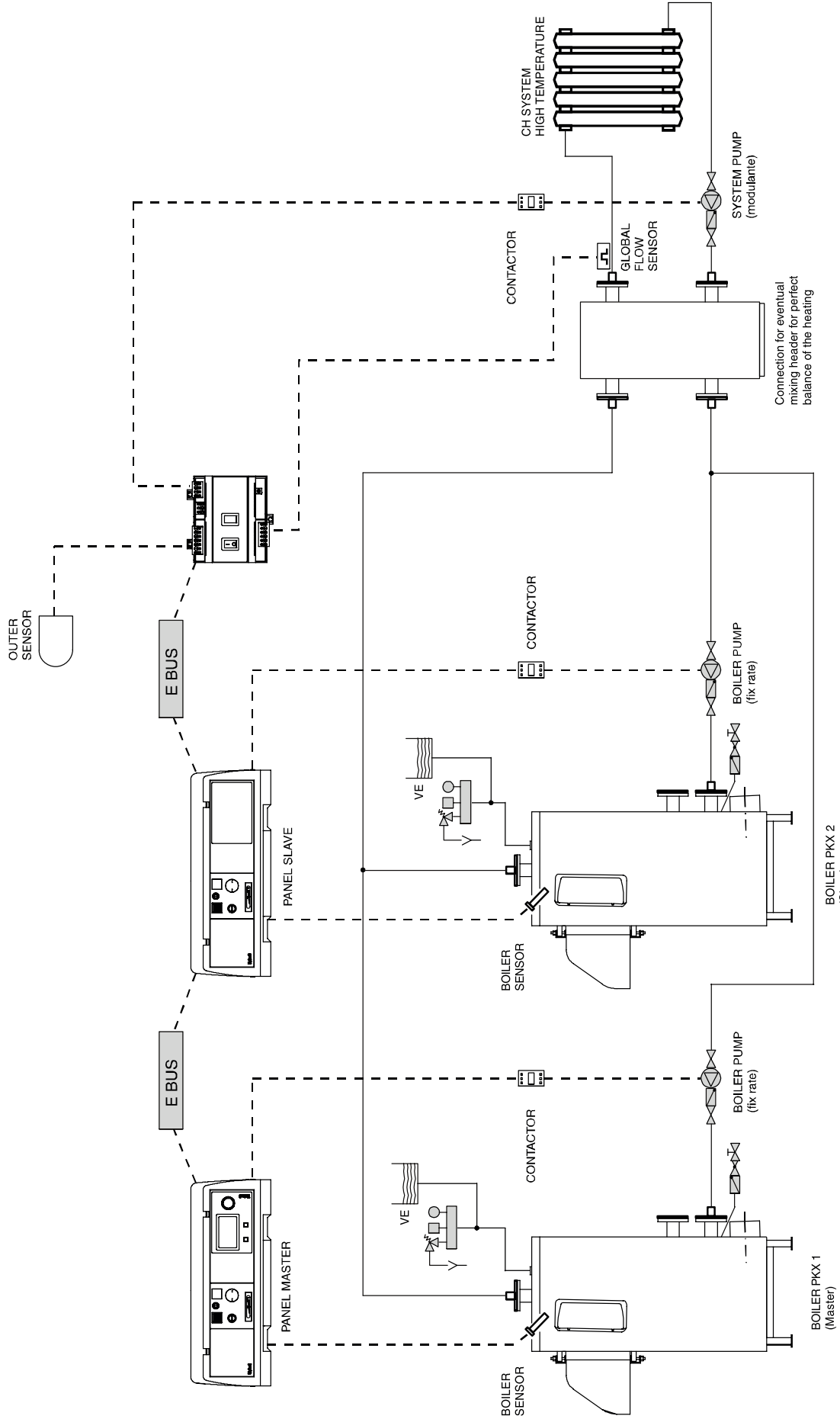

NB: In case of a single system return (low or medium temperature), the connection must ALWAYS be carried out on the inlet and the lower back of the boiler (stub "low-temperature system return").



3.26 - INITIAL LIGHTING

PRELIMINARY CHECKS



The first ignition must be carried out by a qualified technician. Failure to do so could cause injury to persons, animals or damage to property. The manufacturer shall not be held liable for any injury and/or damage.

Before lighting the boiler check that:

- “ the boiler installation has been carried out in accordance with the specific Standards;
- “ the combustion air inlet and the discharge of the products of combustion occur in the correct way in accordance to the specific Standards and regulations in force;
- “ the gas supply system is correctly dimensioned for the boiler's output and is fitted with all the safety and control devices prescribed by the regulations in force;
- “ the boiler's electrical supply is 230 V - 50 Hz;
- “ the system has been filled with water (pressure registered on the gauge 1 bar with pump not running);
- “ all of the system's on-off valves are open;
- “ the mains gas supply corresponds to the one which the boiler has been calibrated for: otherwise convert the boiler to use the available gas; this operation must be carried out by a qualified technician in compliance to the regulations in force;
- “ the gas supply cock is open;
- “ there are no gas leaks;
- “ the external mains supply switch is in the on position;
- “ the boiler system's safety valve is not blocked and that it is connected to the sewage system;
- “ there are no water leaks;
- “ all the necessary ventilation conditions and minimum clearance distances are guaranteed for subsequent servicing.

LIGHTING AND SHUTTING DOWN PROCEDURES

For lighting and shutting down the boiler refer to the “INSTRUCTIONS GUIDE FOR THE PERSON IN CHARGE OF THE APPLIANCE”

Information to be passed on to the person in charge of the appliance

The person in charge of the appliance must be instructed on the

use and operation of the boiler and in particular detail:

- Hand over to the person in charge of the appliance the booklet: “INSTRUCTIONS GUIDE FOR THE PERSON IN CHARGE OF THE APPLIANCE”, as well as all the other literature relative to the appliance, and placed in the envelope contained in the packaging,. The person in charge of the appliance must retain this literature for any future reference.
- Inform the person in charge of the appliance of the importance of the air vents and of the flue outlet system, stressing the fact that absolutely no modification can be made.
- Inform the person in charge of the appliance regarding the control of the system's water pressure and how to restore it to the correct value.
- Explain and demonstrate to the user the correct function and adjustment of the temperature, thermostats and radiators for the economic use of the system.
- Remind the person in charge of the appliance that in order to comply to the regulations in force the boiler has to be inspected and serviced annually and the measurement of the combustion efficiency should be carried out as required by the national regulations in force.
- If the appliance is sold or transferred to another owner or if the present user moves home and leaves the appliance installed, ensure yourself that the manual always follows the appliance so that it can be consulted by the new owner and/or installer.

The WKV boilers are forced water circulation system boilers: therefore it is necessary to ensure that the water circulates when the burner is firing.

You must avoid the burner firing without the system pump being activated; otherwise the safety thermostat could intervene.

The room ambient temperature will be adjusted via the mixing valve managed by the heating controller.

When the burner fires or turns off you could hear a slight noise caused by the structure. This should not give cause for concern because these thermal expansions have been foreseen in the developing phase.

Instructions for the installer

3.23 - BURNER PRESSURE ADJUSTMENT WKV 150



WARNING!

All the instructions indicated below are for the exclusive use of qualified service technicians or installers.



All the boilers are supplied already calibrated and tested. However, if it is necessary to change the calibration, the gas valve must be re-calibrated. Warning: during this operation do not request any DHW draw-off .

A) Max output adjustment

- Remove the sampling point cap and insert a suitable C02 gas analyser in the flue outlet terminal.

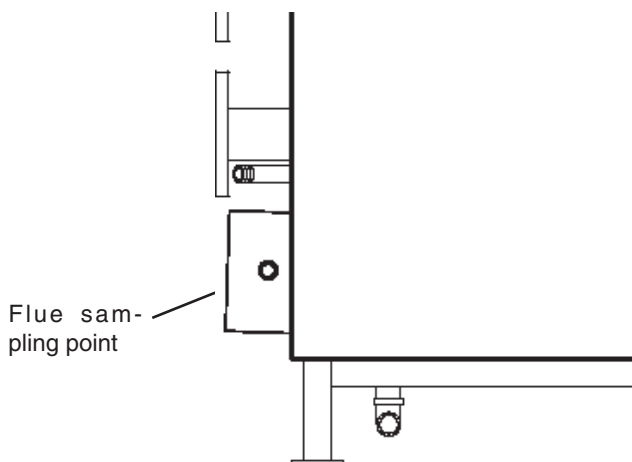

- Via the e-bus controller activate the "Test" mode and run the boiler at maximum output.
- Check that the C02 values are within the values indicated in the table "Burner pressures"
- If necessary correct the value by turning the adjustment screw "A" in a CLOCKWISE direction to decrease the value and in an ANTICLOCKWISE direction in order to increase it.

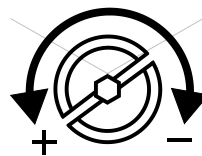
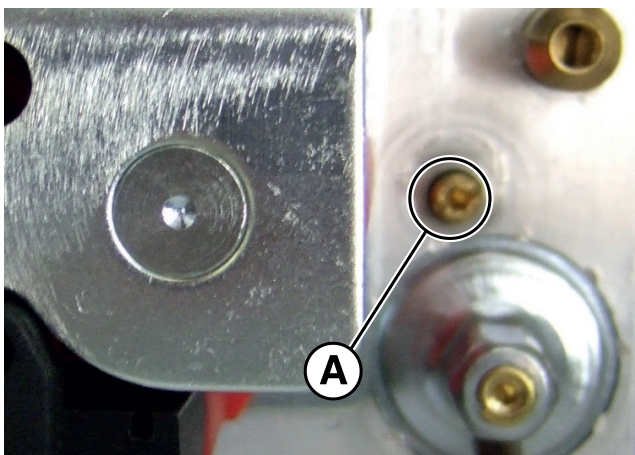

MAXIMUM OUTPUT
ADJUSTMENT SCREW

B) Min output adjustment

- Via the e-bus controller change the "Test" mode and run the boiler at minimum output (refer to procedure illustrated on page 43).
- Check that the C02 values are within the values indicated in the table "Burner pressures"
- If necessary correct the value by turning the adjustment screw "B" in a CLOCKWISE direction to increase the value and in an ANTICLOCKWISE direction in order to decrease it.

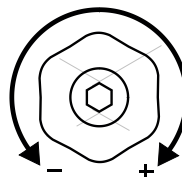
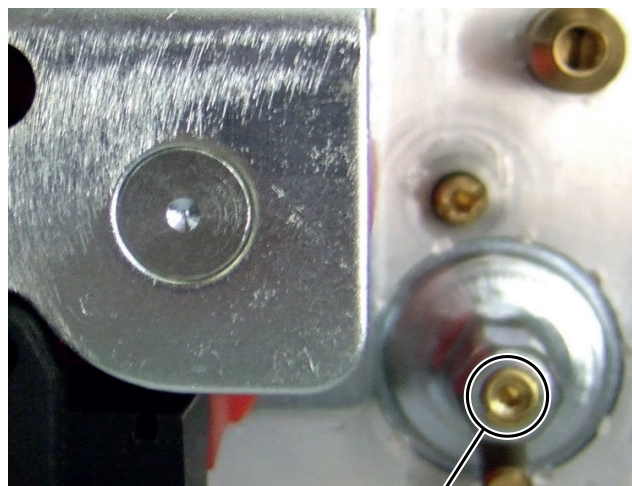

MINIMUM OUTPUT
ADJUSTMENT SCREW



Note: To disable the "Test" mode press the left key.

C) COMPLETION OF THE BASIC ADJUSTMENTS

- Check the C02 values at the minimum and maximum input.
- If necessary make the required adjustments



To ensure correct operation the C02 values have to be adjusted with extreme care respecting the values indicated in the table.

- Replace the protective cap on the sampling test point on the flue outlet terminal.

In case of gas valve replacement or difficult ignition:

Tighten the maximum adjustment screw "A" in a clockwise direction until you arrive to the abutting end, than slacken for 7 turns.

Verify boiler ignition; if the boiler goes into lockout slacken the screw "A" again of one turn, than retry to light the boiler. If the boiler goes into lockout again, carry out the above indicated operations until the boiler fires.

At this point carry out the burner adjustment as previously indicated.

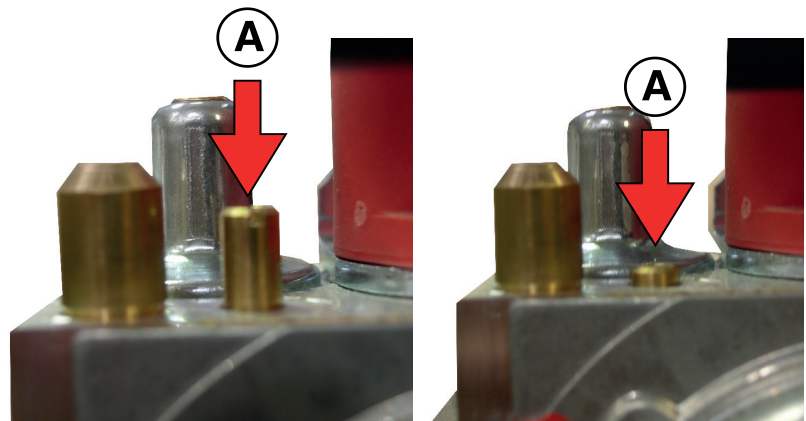

INJECTORS - PRESSURES

WKV 150

Check the CO₂ levels often, especially at low output

Gas Type	Supply Pressure (mbar)	Diafraghm collettore (Ø e n. fori)	Levels CO ₂ (%)		Fan speed %		Ø Injectors (mm)	Consump. min.	Consump. max.	Starting Power %
			min	max	FL min	FH max				
Gas nat. (G20)	20	-	9,1	9,1	31	96	9,0	3,7 m ³ /h	14,8 m ³ /h	60

3.25 - BURNER PRESSURE ADJUSTMENT WKV230 - WKV300 - WKV348



WARNING!
All the instructions indicated below are for the exclusive use of qualified service technicians.



All the boilers are supplied already calibrated and tested. However, if it is necessary to change the calibration, the gas valve must be re-calibrated.

Warning: during this operation do not request any DHW draw-off .

- Via the e-bus controller activate the "Test" mode and run the boiler at maximum output (refer to procedure indicated on page xx).
- Check that the percentage of CO₂ is within the values indicated in the table "Burner pressures"
- If necessary correct the value by turning the adjustment screw "A" in a CLOCKWISE direction to increase the value and in an ANTICLOCKWISE direction in order to decrease it.

A) Max output adjustment

- Remove the sampling point cap and insert a suitable CO₂ gas analyser in the flue outlet terminal.

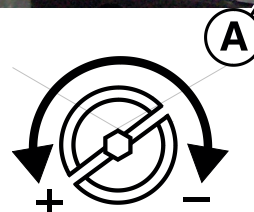
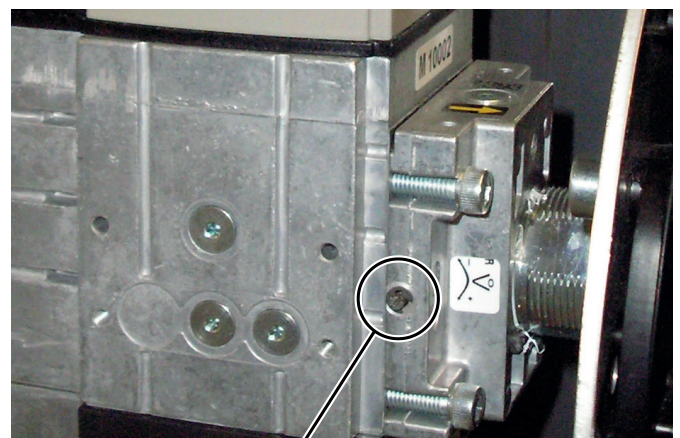
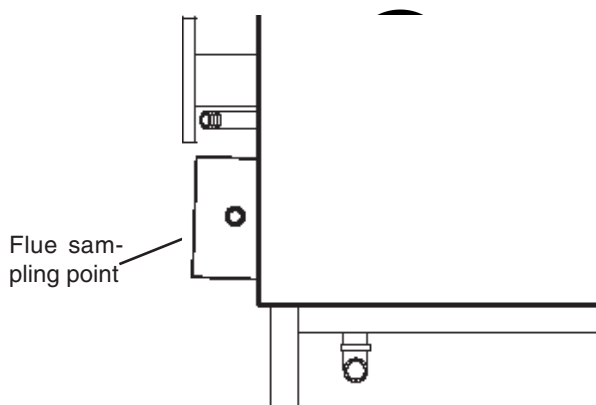

MAXIMUM OUTPUT
ADJUSTMENT SCREW

Instructions for the installer

B) Min output adjustment

Via the e-bus controller Change the "Test" mode and run the boiler at minimum output (refer to procedure illustrated on page 43).

- Check that the CO₂ values are within the values indicated in the table "Burner pressures"
- If necessary correct the value by turning the adjustment screw "B" in a CLOCKWISE direction to increase the value and in an ANTICLOCKWISE direction in order to decrease it.

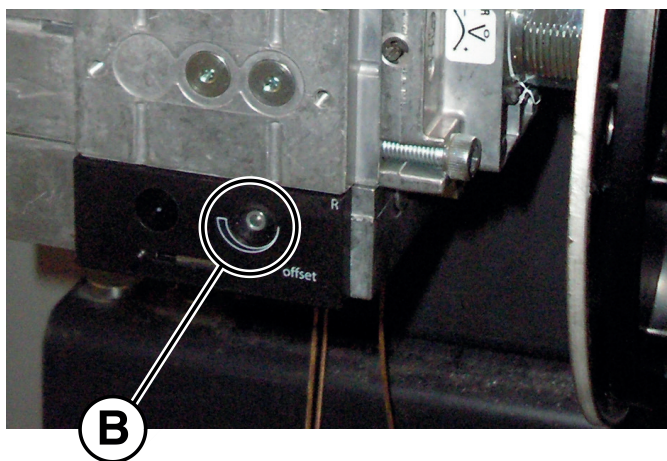

MINIMUM OUTPUT ADJUSTMENT SCREW



C) COMPLETION OF THE BASIC ADJUSTMENTS

- Check the CO₂ values at the minimum and maximum input.
- If necessary make the required adjustments



To ensure correct operation the CO₂ values have to be adjusted with extreme care respecting the values indicated in the table.

- Replace the protective cap on the sampling test point on the flue outlet terminal.

INJECTORS - PRESSURES

WKV 230

Check the CO₂ levels often, especially at low output

Gas Type	Supply Pressure (mbar)	Diafraghm collettore (Ø e n. fori)	Levels CO ₂ (%)		Fan speed %		Ø Injectors (mm)	Consump. min.	Consump. max.	Starting Power %
			min	max	FL	FH				
Gas nat. (G20)	20	-	9,2	9,2	min 24	max 82	15	5,28 m ³ /h	22,83 m ³ /h	60

WKV 300

Gas Type	Supply Pressure (mbar)	Diafraghm collettore (Ø e n. fori)	Levels CO ₂ (%)		Fan speed %		Ø Injectors (mm)	Consump. min.	Consump. max.	Starting Power %
			min	max	FL	FH				
Gas nat. (G20)	20	-	9,1	9,1	24	87	15	7,4 m ³ /h	29,61 m ³ /h	50

WKV 348

Gas Type	Supply Pressure (mbar)	Diafraghm collettore (Ø e n. fori)	Levels CO ₂ (%)		Fan speed %		Ø Injectors (mm)	Consump. min.	Consump. max.	Starting Power %
			min	max	FL	FH				
Gas nat. (G20)	20	-	9,1	9,1	24	99	15	7,4 m ³ /h	34,26 m ³ /h	50

Instructions for HSCP calibration/adjustment

3.25 - ACTIVATION CHIMNEYSWEEPER MODE

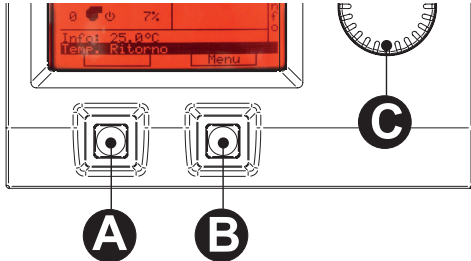

Press key A (store)

Turn the C until "Manual control" appears on the display.



For activating the "CHIMNEYSWEEPER MODE" proceed as follows:

- Press key B (menu)
- Turn the knob C on the display) until the symbol appears
- Press key A (selection)
- Turn the knob "C" until Manual Control appears on the display
- Press key "A" (selection) (and you enter in the menu "Password check")
- Turn the knob "C" to ZERO
- Press key A (1° zero) appears on the display
- Press key A (2° zero) appears on the display
- Press key A (3° zero) appears on the display
- Press key A (4° zero) appears on the display
- Turn the knob C on on

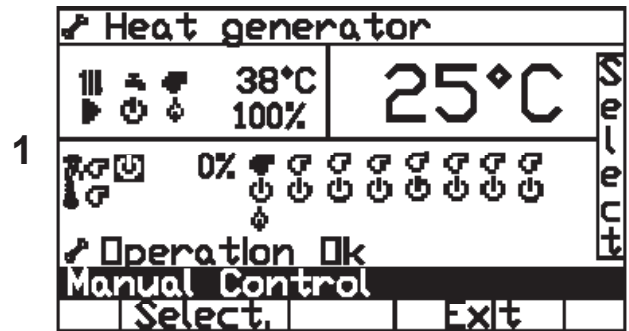

1 Select the activation command of the function

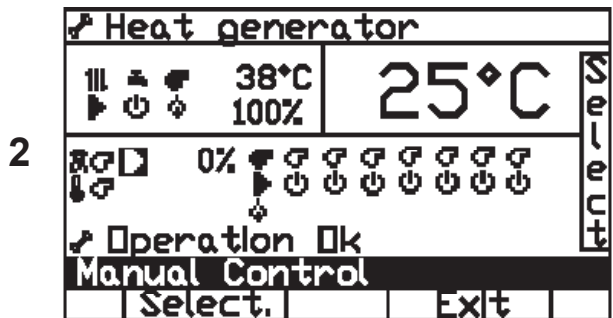

2 Select the modulation level setting and change it as follows: MAXIMUM OUTPUT = 100%

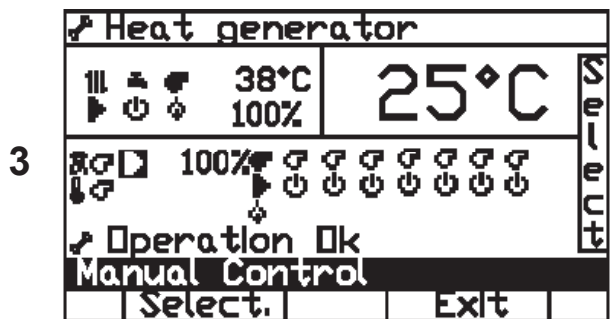

3 The system will fire at the MAXIMUM HEAT OUTPUT = 100%: Proceed with the combustion analysis

Instructions for HSCP calibration/adjustment

3.26 - PROGRAMMING THE OPERATOR PARAMETERS

ATTENTION! OPERATIONS TO BE CARRIED OUT ONLY BY TECHNICIANS TO VERIFY AND MODIFY (IF REQUIRED) THE OPERATING PARAMETERS

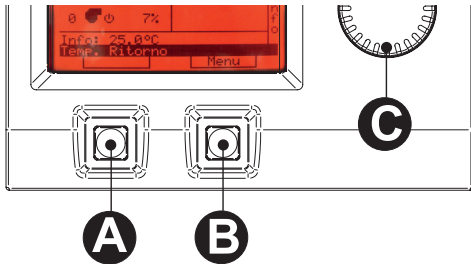





To display/modify the “operating parameters” proceed as follows:

- Press key B (menu)
- Rotate knob C until reaching (symbol )
- Press key A (selection)
- Rotate knob C until “Parameter Settings” appears on the display
- Press key A (selection) (enter the parameter and relative set values screenshot)
- Rotate knob C to scroll the parameter list

To modify the involved parameter

- Press key A (selection) (enter the password)
- Rotate knob C to ZERO
- Press key A (1st zero) appears on the display 

- Press key A (2nd zero) appears on the display 
- Press key A (3rd zero) appears on the display 
- Press key A (4th zero) appears on the display 
- Rotate knob C up 
- Press key A (save)

At this point you can modify the parameters

- Rotate knob C to select the involved parameter
- Press key A (selection)
- Rotate knob C to modify the parameter value
- Press key A (save) to confirm

Instructions for HSCP calibration/adjustment

Position	Identification	Parameter description	DEFAULT SETTINGS			
			WKV 150	WKV 230	WKV 300	WKV 348
1	31	CH: Minimum Setpoint	20	20	20	20
2	39	CH: Maximum Setpoint	85	85	85	85
3	322	Pump: Overrun	5	5	5	5
4	309	System Config. (single master)	3	3	3	3
		System Config. (master in battery)	2	2	2	2
		System Config. (slave)	2	2	2	2
5	619	Ignition modulation	60	60	50	65
6	314	Standby modulation	0	0	0	0
7	319	Maximum Modulation	96	99	90	99
8	346	Minimum Modulation	32	29	24	28
9	488	Fan: PWM @ Max	10	10	20	20
10	527	Fan: Set./Rev	2	2	3	3
11	161	Burner power	150	230	300	350
12	483	Max differential Temp.	0	0	0	0
13	622	Minimum flow sensor	0	0	0	0
14	34	Burner hysteresis	50	50	50	50
15	336	Temperature Gradient	10	10	10	10
16	353	Proportional adjustment	20	20	20	20
17	354	Integrative adjustment	12	12	12	12
18	478	Derivative Adjustment	10	10	10	10
19	486	Fan: Prop. Adjust.	6	6	14	14
20	487	Fan: Int. Adjust.	1	1	2	2
21	337	Modulation Gradient	1000	1000	2000	2000
22	526	Fan: Max. Speed	100	110	100	110
23	777	APS Control	0	0	0	0
24	793	Chimney obstruction sensor	1	1	1	1

4

INSPECTIONS AND MAINTENANCE



Inspections and maintenance performed professionally and according to a regular schedule as well as the use of original spare parts are of the utmost importance for fault-free operation of the boiler and to guarantee its long life.

Yearly maintenance of the appliance is mandatory in compliance with Laws in force.



Failure to perform Inspections and Maintenance can entail material and personal damage.

We therefore recommend stipulating an inspection or maintenance contract.

Inspections help to determine the actual status of the appliance and to compare it with the nominal status. This is done through measuring, controls and observation.

Maintenance is required to eliminate any differences between the actual status and the nominal status. This is normally done by cleaning, setting and replacing individual components subject to wear.

Maintenance intervals and their extent are determined by a specialist based on the status of the appliance ascertained through inspection.

Inspection and maintenance instructions



To assure long-term functioning of your appliance and to avoid altering its approved status, only original spare parts must be used.

Before proceeding with maintenance, always perform the following operations:

- Disconnect the electric mains switch.
- Isolate the appliance from the electric mains by means of an isolated device with a contact opening of at least 3 mm (e.g. safety devices or power switches) and make sure that it cannot be re-connected accidentally.
- Close the gas shut-off valve upstream the boiler.
- Close any shut-off valves on the heating flow and return pipes.

After having completed all maintenance work, always perform the following operations:

- Open the heating flow and return pipes.
- If necessary, restore the heating system pressure until it reaches the static pressure relative to the highest point of the system.
- Open the gas shut-off valve.
- Reconnect the appliance to the electric mains and engage the switch.
- Make sure the appliance is gas tight and watertight.
- Vent the heating system and restore pressure if necessary.

Should you decide to temporarily deactivate the boiler, you must:

- a) shut off the various supplies: electric, water and fuel;
- b) empty the water system if antifreeze is not used.

Boiler body maintenance



Danger!
Before performing any maintenance, make sure the boiler and its components have cooled off.

Disconnect the boiler from the electric mains and shut the gas supply to the appliance.



Attention!
Before cleaning the boiler body, protect the panel board against any water sprays.

Once a year, at the end of the heating season, the boiler must receive a general cleaning.

Before performing any maintenance, make sure that all the precautions referred to in the previous point have been taken.

To proceed with maintenance you must:

- disconnect power by acting on the main switch;
- remove the burner, which could be overhauled at the same time;
- open the furnace door to access the combustion chamber;
- remove the smoke chamber access door;
- make sure the internal parts are intact.

Checking status of gaskets and insulation fibres



The insulation fibre of the door can show cracks after a short time of operation; this however does not reduce its insulation capacity nor jeopardise its lifespan.

Check the status of the seal gasket which must not show signs of deterioration; if so, it must be replaced, using only original spare parts.

Check the status of the smoke chamber inspection cover gasket.
Replace it if worn, using only original spare parts.

Components to check during yearly inspection

COMPONENT:	VERIFY:	CONTROL/INTERVENTION MEASURE:
Ts (safety thermostat)	Does the thermostat place the boiler in safety when overheating?	Bring the boiler to operating temperature with the pumps stopped.
System expansion vessel	Does the vessel contain the right amount of air?	Check pressure. Pressurise the boiler (open the pump bleeder). Open the heating circuit closing valves.
Door gaskets	Does smoke seep through the door gaskets?	Further tighten the door screws. Replace the sealing gasket and possibly the internal gasket of the door.
Smoke chamber gaskets	Does smoke seep through the smoke chamber gaskets?	Further tighten the smoke chamber nuts. Replace the sealing gaskets.
Ignition electrode	Does ignition occur correctly?	Make sure that the distance between electrode and burner is 9-10 mm. Make sure that the distance between the electrode tips are 3 mm. Check the discharge with closed gas.
Detection electrode	Is the flame detection correct?	Make sure that the distance between electrode and burner is 15-18 mm. Check ignition and detection with cold system.
Burner	Is the burner still in optimal operating conditions?	Visual check the fibre; if dirty, clean using water jet from inside out

5

ERROR CODES

5.1 - ERROR CODES DISPLAY

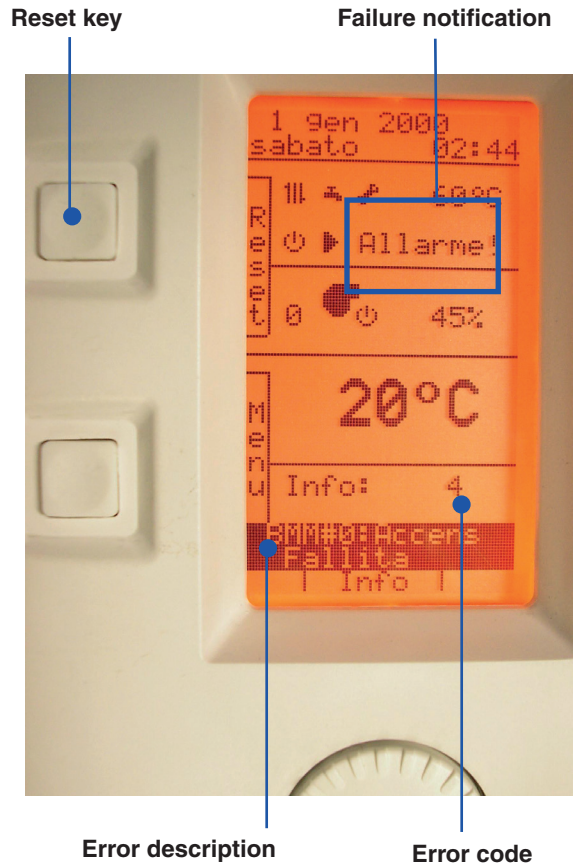

Error codes of EBUS control unit are indicated below together with its meaning and corrective actions.

<p>Code:</p> <p>13</p>	<p>Meaning: Sanitary sensor failure (only if the boiler is coupled with an outer storage tank)</p> <p>Solution: Make sure the sensor and/or wiring is efficient</p>	<p>Code:</p> <p>2</p>	<p>Meaning: Insufficient gas pressure</p> <p>Solution: Check the pressure; if pressure is correct, check the pressure switch efficiency and/or wiring</p>
<p>Code:</p> <p>32</p>	<p>Meaning: Mains voltage < 190 Vac</p> <p>Solution: Check the mains voltage, if < 190 Vac, if the mains voltage is correct replace the control board</p>	<p>Code:</p> <p>29</p>	<p>Meaning: Presence of water inside the smoke chamber</p> <p>Solution: Verify the correct operation of the condensation draining system</p>

Code: **6** **Meaning:**
Excessive water temperature detected by the heating sensor (SR) (> 95°C)

Solution:
Check water circulation in installation

Code: **5** **Meaning:**
Loss of the flame signal during operation

Solution:
Press the unblock key on the panel

Code: **4** **Meaning:**
No flame detected during the ignition phase

Solution:
Press the unblock key on the panel

Code: **24** **Meaning:**
Modulating fan failure

Solution:
Check the fan wiring

Code: **26** **Meaning:**
Modulating fan failure

Solution:
Check the fan wiring

Code: **28** **Meaning:**
Flue pressure switch intervention (PV)

Solution:
Check the flue discharge state

Code: **16** **Meaning:**
Heat exchanger freezing

Solution:
Carefully defrost the heat exchanger

Code: **1** **Meaning:**
Safety thermostat intervention (TL)

Solution:
Press the unblock key on the panel

Code: **12** **Meaning:**
Heating system failure (SR)

Solution:
Make sure the sensor and/or wiring is efficient

Code: **30** **Meaning:**
Modification of the operating parameters due to EMC disturbances

Solution:
Restore the factory settings

Code: **11** **Meaning:**
Flame detected before starting the ignition cycle

Solution:
Disconnect the detection electrode cable from the control board; if the error code disappears, replace the cable, otherwise replace the control board

Code: **20** **Meaning:**
Flame detected once the burner has been turned off

Solution:
Disconnect the gas valve cable from the control board; if the error code disappears, replace the control board, otherwise replace the gas valve

Code: **10** **Meaning:**
Inner failure

Solution:
Replace the control board

schuster®

CE 0035324 - 1ª edizione 10/14

The manufacturer declines every responsibility for the possible inaccuracies if owed to errors of transcript or press. Also reserves the right to bring those changes that it will hold necessary to its own products or profits, without jeopardizing its essential characteristics

Schuster - via Padana Inferiore 52/C - 29012 Caorso (PC) - Italy - e-mail: info@schusterboilers.com - www.schusterboilers.com