

BWA

90

Warning: this manual contains instructions to be used exclusively by the installer and/or a competent person in accordance with the current laws in force. The end user MUST not make any alterations to the boiler.

Failure to follow the instructions indicated in this manual, which is supplied with the boiler, could cause injury to persons, animals or damage to property. The Manufacturer shall not be held liable for any injury and/or damage.

CONTENTS

1 GENERAL INFORMATION	3
1.1 Symbols used in this guide	3
1.2 Correct use of the appliance	3
1.3 Water treatment	3
1.4 Information to be passed over to the person in charge of the appliance	3
1.5 Safety warnings	4
1.6 Data badge	5
1.7 General warnings	6
2 TECHNICAL FEATURES AND DIMENSIONS	7
2.1 Technical features	7
2.2 Dimensions	8
2.3 Main components	11
2.4 Boiler water circuit	12
Operating performances according to the Standard UNI 10348	13
2.6 General features	13
3 INSTRUCTIONS FOR THE INSTALLER	14
3.1 General warnings	14
3.2 Installation standards	15
3.3 Packaging	15
3.4 Boiler location in a boiler room	16
3.5 Installation on existing systems	17
3.6 Gas connection	17
3.7 Connection return and flow system pipes	18
3.8 Supplemental safety, security and control devices prescribed by the Law 01-12-75	19
3.9 Safety pressure relief valve	20
3.10 Working pressure	20
3.11 Mixing header filter	21
3.12 Mixing header	21
3.13 Condensing drain	22
3.14 Water treatment	22
3.15 Fluing connections	24
3.16 Electrical connections	25
General warnings	25
Connection to electrical supply 230V	25
Room thermostat and/or heating controller E8 connection	25
3.17 Practical connection diagrams	26
3.18 Management connections diagram with E8 regulator	29
3.19 Examples of installation (functional diagram)	31
3.20 Examples of installations with optional kits	37
3.21 Filling the system	41
3.22 Preliminary checks	42
3.23 Burner adjustment	43
3.24 Programming of the operational parameters	43
4 SERVICING SCHEDULE	47
Instructions for checking and servicing the appliance	47
Table of the resistance values in function of the heating and domestic sensor temperature	48
Verifica e pulizia del sifone scarico condensa	48
5. FAULT FINDING	50
Display off error codes on heating controller E8	51
6 DECLARATION OF CONFORMITY	53

1

GENERAL INFORMATION

1.1 - SYMBOLS USED IN THIS GUIDE

When reading this guide particular care has to be given to the parts marked with the followings symbols:



DANGER!
Indicates serious danger for your personal safety and for your life



WARNING!
Indicates a potentially dangerous situation for the product and the environment



NOTE!
Suggestions for the user

1.2 - CORRECT USE OF THE APPLIANCE



The ALKON appliance has been designed utilizing today's heating technology and in compliance with the current safety regulations. However, following an improper use, dangers could arise for the safety and life of the user or of other people, or damage could be caused to the appliance or other objects. The appliance is designed to be used in pumped hot water central heating systems. Any other use of this appliance will be considered improper. The Manufacturer declines any responsibility for any damages or injuries caused by an improper use; in this case the risk is completely at the user's responsibility. In order to use the appliance according to the scopes it was designed for it is essential to carefully follow the instructions indicated in this guide.

1.3 - WATER TREATMENT



- The hardness of the mains water supply conditions the frequency with which the heat exchanger is cleaned.
- In hard water areas where the main water can exceed 15°f total hardness, a scale reducing device is recommended. The choice of this device has to be made taking into consideration the characteristics of the water.
- In order to improve the resistance to lime scale it is recommended to adjust the domestic hot water temperature as near as possible to the one you really require.
- We recommend you to check the state of cleanliness of the domestic hot water heat exchanger at the end of the first year and subsequently, on the basis of the lime scale found, this period can be extended to two years.

1.4 - INFORMATION TO BE HANDED OVER TO THE USER



The user has to be instructed on the use and operation of his heating system, in particular:

- Hand over these instructions to the end user, together with any other literature regarding this appliance, placed inside the envelope contained in the packaging. **The user has to keep these documents in a safe place in order to always have them at hand for future reference.**
- Inform the user on the importance of air vents and of the flue outlet system, stressing the fact that is absolutely forbidden to make any alterations to the boiler.
- Inform the user how to check the system's water pressure as well as informing him how to restore the correct pressure.
- Explain the function of time and temperature controls, thermostats, heating controls and radiators, to ensure the greatest possible fuel economy.
- Remind the user that it is obligatory to carry out a comprehensive service annually and a combustion analysis every two years (in compliance with the national law).
- If the appliance is sold or transferred to another owner or if the present user moves home and leaves the appliance installed, ensure yourself that the manual always follows the appliance so that it can be consulted by the new owner and/or installer.

Failure to follow the instructions indicated in this guide, which is supplied with the boiler, could cause injury to persons, animals or damage to property. The manufacturer shall not be held liable for any such injury and/or damage.

General Information

5 - SAFETY WARNINGS



WARNING!

The installation, adjustment, and servicing of this appliance must be carried out by a competent person and installed in accordance with the current standards and regulations. Failure to correctly install this appliance could cause injury to persons, animals or damage to property. The manufacturer shall not be held liable for any injury and/or damage.



DANGER!

Servicing or repairs of the appliance must be carried out by The Manufacturer authorised service technicians; The Manufacturer recommends drawing up a service contract. Bad or irregular servicing could compromise the safe operation of the appliance, and could cause injury to persons, animals or damage to property for which The Manufacturer shall not be held liable.



Modifications to parts connected to the appliance

Do not carry out any modifications to the following parts:

- the boiler
- to the gas, air, water supply pipes and electrical current
- to the flue pipe, safety relief valve and its drainage pipe
- to the constructive components which influence the appliance's safe operation



WARNING!

When tightening or loosening the screw pipe connections, use only adequate fork spanners. The improper use and/or the use of inadequate equipment can cause damages (for example water or gas leakages).



WARNING!

Indications for appliances operating with propane gas

Ensure yourself that before installing the appliance the gas tank has been purged.

For a correct purging of the tank contact the liquid gas supplier or a competent person who has been legally authorized.

If the tank has not been correctly purged problems could occur during ignition.

If this occurs contact the liquid gas tank's supplier.

Smell of gas

If you smell gas follow these safety indications:

- Do not turn on or off electrical switches
- Do no smoke
- Do not use the telephone
- Close the main gas tap
- Open all windows and doors where the gas leakage has occurred
- Inform the gas society or a company specialized in installing and servicing heating systems



Explosive and easily inflammable substances

Do not use or leave explosive or easily inflammable material (as for example: petrol, paint, paper) in the room where the appliance has been installed.



1.6 DATA BADGE

CE marking

The CE marking certifies that the boilers meet:

- The essential requirements of the gas appliance directive (directive 2009/142/EEC)
- The essential requirements of the electromagnetic compatibility directive (2004/108/EEC)
- The essential requirements of the efficiency directive (92/42/EEC)
- The essential requirements of the efficiency directive (directive 2006/95/EEC)

KEY:

- 1 = CE monitoring body
- 2 = Type of boiler
- 3 = Boiler model
- 4 = Number of stars (directive 92/42 EEC)
- 5 = (S.N°) Serial Number
- 6 = P.I.N. Product Identification Number
- 7 = Types of approved flue gas exhaust configurations
- 8 = (NOx) NOx Class

- A = Heating circuit characteristics
- 9 = (Pn) Effective nominal output
- 10 = (Pcond) Effective output in condensation
- 11 = (Qn) Maximum heat output
- 12 = (Adjusted Qn) Adjusted for rated heat output
- 13 = (PMS) Max. heating operating pressure
- 14 = (T max) Max. heating temperature









- B = Domestic hot water circuit characteristics
- 15 = (Qnw) Rated heat output in domestic hot water function (if different to Qn)
- 16 = (D) Specific D.H.W. flow rate according to EN 625 - EN 13203-1
- 19 = (PMW) Max. domestic hot water operating pressure
- 20 = (T max) Max. domestic hot water temperature

- C = Electrical characteristics
- 21 = Electrical power supply
- 22 = Consumption
- 23 = Protection rating

- D = Countries of destination
- 24 = Direct and indirect countries of destination
- 25 = Gas category
- 26 = Supply pressure

- E = Factory settings
- 27 = Adjusted for gas type X
- 28 = Space for national brands

- G = ErP
- 29 = Seasonal space heating energy efficiency
- 30 = Energy efficiency in DHW production mode

②	
Model	③
S.N°	⑤
PIN	⑥
Types	⑦
NOx	⑧
A 	Pn ⑨ kW Pcond ⑩ kW Qn ⑪ kW Adjusted Qn ⑫ kW PMS ⑬ bar T max ⑭ °C
B 	Qnw ⑮ kW D ⑯ l/min PMW ⑰ bar T max ⑳ °C
G ErP 	ηs ⑲ %  ηwh ⑳ % 
E Factory setting 	D Countries of destination
⑳ mbar <input type="checkbox"/> ㉑ mbar <input type="checkbox"/> ㉒ mbar <input type="checkbox"/> ㉓ mbar <input type="checkbox"/> ㉔ mbar <input type="checkbox"/> ㉕ mbar <input type="checkbox"/> ㉖ mbar <input type="checkbox"/> ㉗ mbar <input type="checkbox"/>	㉘ ㉙ ㉚
C Electrical Power supply 	
㉛ V HZ ㉜ W	
IP class: ㉝	
  ㉞	①
Made in Italy	

General Information

1.7 - GENERAL WARNINGS

This instruction manual is an integral and indispensable part of the product and must be retained by the person in charge of the appliance.

Please read carefully the instructions contained in this manual as they provide important indications regarding the safe installation, use and servicing of this appliance.

Keep this manual in a safe place for future reference.

The installation and servicing must be carried out in accordance with the regulations in force according to the manufacturer's instructions and by legally competent authorized persons.

By a competent person, we imply a person who has a specific technical qualification in the field of components for central heating systems for domestic use, domestic hot water production and servicing. The person must have the qualifications foreseen by the current laws in force.

Bad or irregular servicing could compromise the safe operation of the appliance, and could cause injury to persons, animals or damage to property. The manufacturer shall not be held liable for any such injury and/or damage.

Before carrying out any cleaning or servicing turn off the electrical supply to the boiler by means of the ON/OFF switch and/or by means of the appropriate shutdown devices.

Do not obstruct the intake/outlet terminal ducts.

In the event of failure and/or faulty functioning of the appliance,

switch off the boiler. Do not attempt to make any repairs: contact qualified technicians.

Any repairs must be carried out by authorized technicians and using only original spare parts. Non-observance of the above requirement may jeopardize the safety of the appliance.

To guarantee the efficiency and correct functioning of the appliance it is indispensable to have the boiler serviced annually by a qualified person.

If the boiler remains unused for long periods, ensure that any dangerous parts are rendered innocuous.

If the appliance is sold or transferred to another owner or if the present user moves home and leaves the appliance installed, ensure yourself that the manual always follows the appliance so that it can be consulted by the new owner and/or installer.

Only original accessories must be used for all appliances supplied with optionals or kits (including electrical ones). This appliance must be used only for the purposes for which it has been expressly designed. Any other use shall be considered incorrect and therefore dangerous.

2

TECHNICAL FEATURES AND DIMENSIONS

2.1 - TECHNICAL FEATURES

The BWA 90 boiler is a low water content thermal element (about 10 lt), with a built-in premix gas burner, for heating only. It is mainly used as element for the modular boilers in cascade (max 4 boilers).

PECULIAR CHARACTERISTICS:

- 1) modular structure to tall integration.
- 2) mainly for outdoor installation: IPX5D.
- 3) prearranged for quick installation " Plug and Play " also in cascade of up to 4 modules.
- 4) modulating pump driven by the electronic PCB, for the maximum efficiency in condensation
- 5) optional regulator for the management of the single and cascade modules and the thermal loads (remote controllable)
- 6) modulation ratio of the single module
- 7) control for every single module, with display and diagnostic

Optional regulator for the management of the single or cascade modules and of the remotable thermal loads These boilers have a normal input of 90 kW and they have been approved in order to operate with natural gas or LPG in all the European countries, according to the The Manufacturer instructions.

The ALKON boiler is supplied complete with all the safety and control devices in accordance with all the current regulations and its technical and functional features comply with the regulations prescribed by the law No. 1083 dated 06/12/1971 concerning safety and use of combustible gas and with the requirements prescribed in the law No. 10 dated 09/01/1991 and any subsequent amendments – Gas Directive 90/396 CEE – Efficiency Directive 92/42 CEE – Electromagnetic Compatibility Directive 89/336 CEE – Low Voltage Directive 73/23 CEE.

The boilers of the **ALKON** range are rated in the class 4 star category for efficiency, according to the Directive 92/42 CEE and D.P.R. 660; moreover they are rated in Class 5 for their NOx emissions in accordance to the Standards EN 297 and EN 483.

DESCRIPTION OF COMPONENTS AND FEATURES

- 1 Aluminium heat exchanger/condenser;
- 2 **premixed combustion group working at constant air-gas ratio**
- 3 Safety limit thermostat;
- 4 Flow temperature sensor;
- 5 Return temperature sensor;
- 6 Automatic air vent;
- 7 Control panel with electrical protection IP X5D;
- 8 Condensate drain siphon;
- 9 Electronic ignition;
- 10 Flame modulation in function of the absorbed power;
- 11 Pump overrun function;
- 12 **modulating pump**
- 13 **eBUS connection**
- 14 **E8 regulator (optional)**
- 15 **BCM (optional)**

16 ON/OFF switch

17 temperature adjustment in heating mode between 30 and 85°C;

What to order for 1x ALKON 90:

- 1 - boiler BWA 90 MASTER 41010336(NG)
– 41010337 (LPG)

What to order for (2 up to 4) ALKON 90:

- 1/2/3 - boilers BWA 90 SLAVE
41010456 (NG) – 41010458 (LPG)
- 1 – outdoor cover kit for 2 boilers 00361522
- outdoor cover kit for 3 boilers 00361523
- outdoor cover kit for 4 boilers 00361524

OPTIONAL KITS in general:

- Additional safety kit + manifolds 00361528
- Additional protection and control kit 00361316
- External frame for safety devices kit xxxxxxxx
- Expansion vessel supporting kit 00361529
- E8 regulator kit 00361332
- Box for E8 regulator kit 00361359
- BM8 remote control kit 00361358
- BCM panel kit 00361602
- Condensate neutralizing kit NH500 00361551
- E8 zone expanding kit 00361545

Installation of 1x BWA 90

- Hydraulic header connection kit (DN 65) 00361484
- Hydraulic header kit up to 180 kW 00361499
- Y filter kit (DN65) 00361488

Installation of 2x BWA 90 in cascade

- Hydraulic header connection kit (DN 65) 00361484
- Hydraulic header kit up to 180 kW 00361499
- Y filter kit (DN65) 00361488

Installation of 3x or 4x BWA 90 in cascade

- Hydraulic header connection kit (DN 100) 00361487
- Hydraulic header kit up to 450 kW 00361500
- Y filter kit DN100 00361489

Smoke kit for indoor installation:

- Smoke thermostat kit for cascade installation 00361451
- Expansion smoke thermostat kit for base cascade 00361339
- Expansion smoke thermostat kit for 3 boilers in cascade 00361340
- Expansion smoke thermostat kit for 4 boilers in cascade 00361341

Technical features and dimensions

2.2 - DIMENSIONS

FRONT VIEW

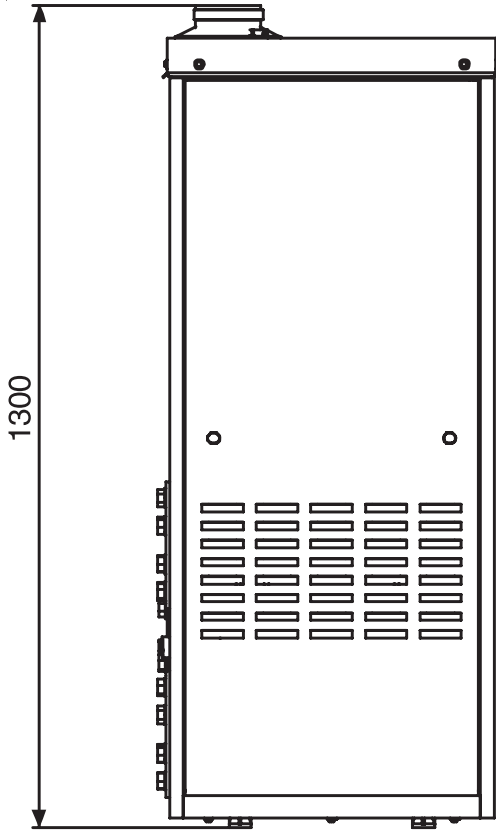

LEFT SIDE VIEW

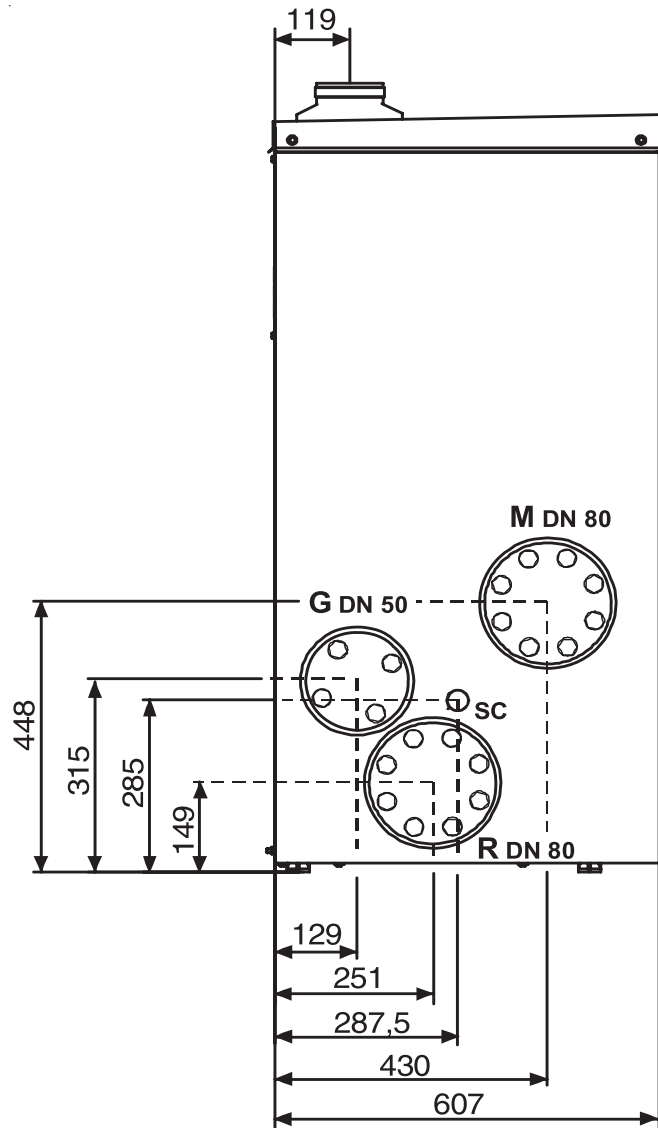

VIEW FROM ABOVE

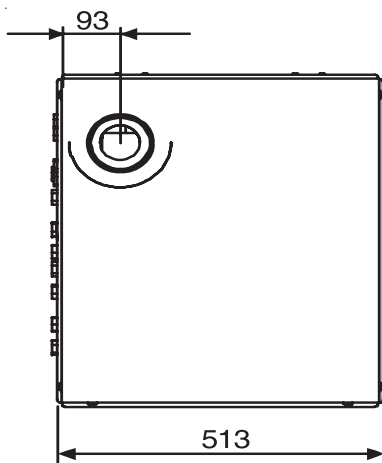

- R** CH safety system return DN 80
- M** CH flow system DN 80
- G** Gas Inlet DN 50
- Sc** Outlet condensate drain siphon Ø 32

Technical features and dimensions

DIMENSIONS BWA 90 master + KIT SAFETY DEVICES + HYDRAULIC HEADER +Y FILTER KIT

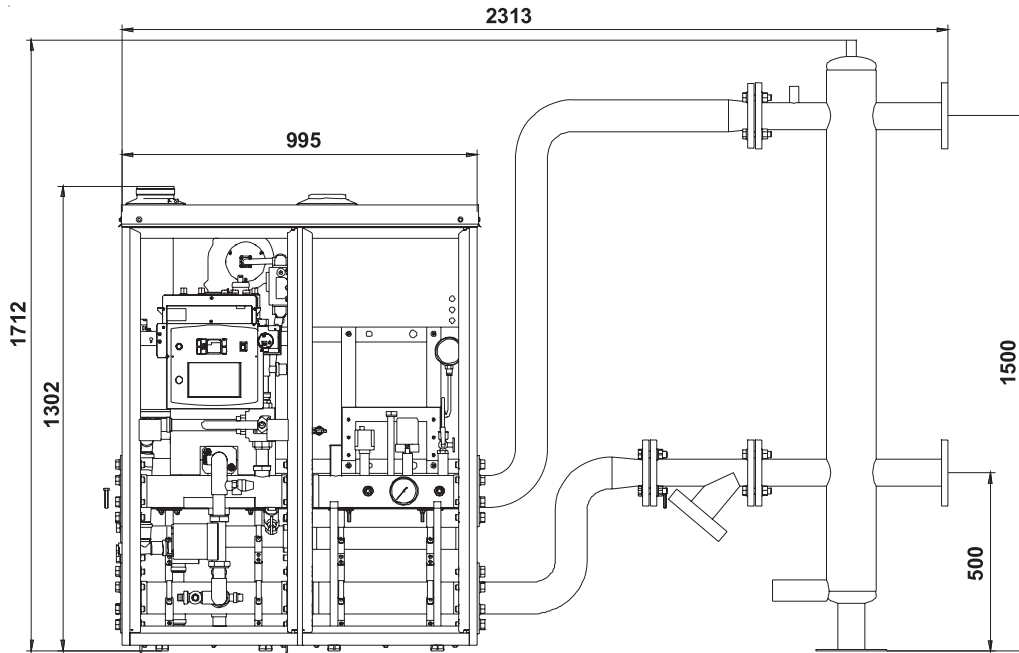

DIMENSIONS BWA 90 BATTERY (n.2 boilers) + KIT SAFETY DEVICES + HYDRAULIC HEADER +Y FILTER KIT

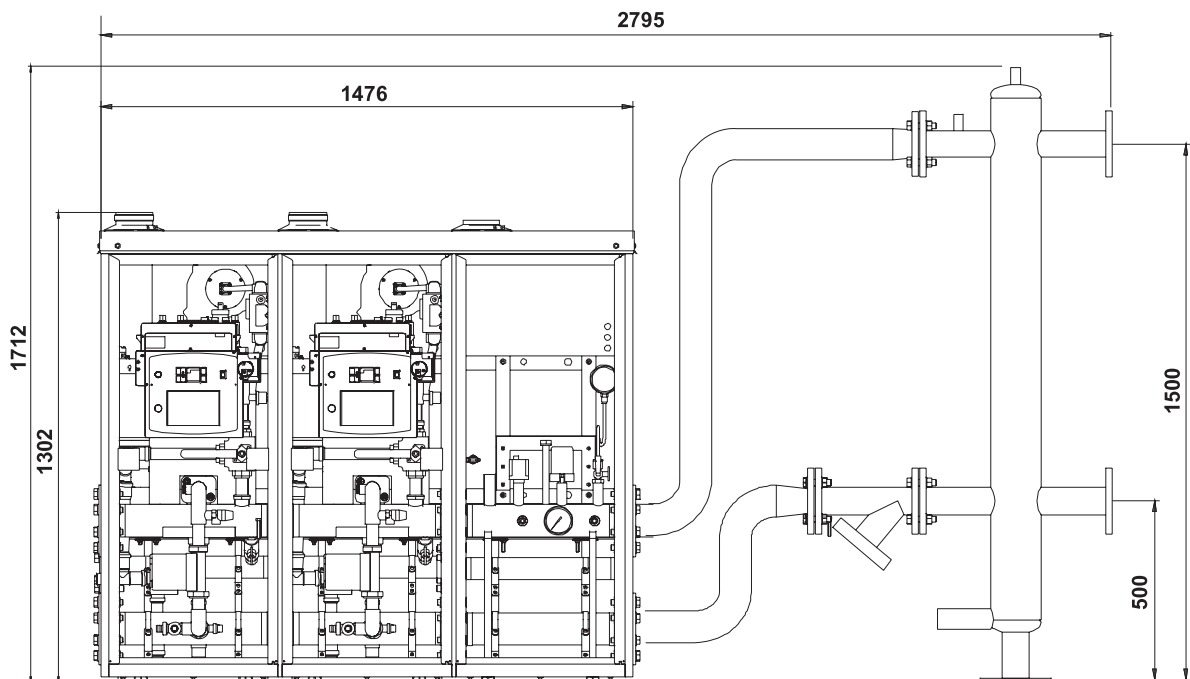

Technical features and dimensions

DIMENSIONS ALKON 90 in BATTERY (n.3 boilers) + KIT SAFETY DEVICES + HYDRAULIC HEADER + Y FILTER KIT

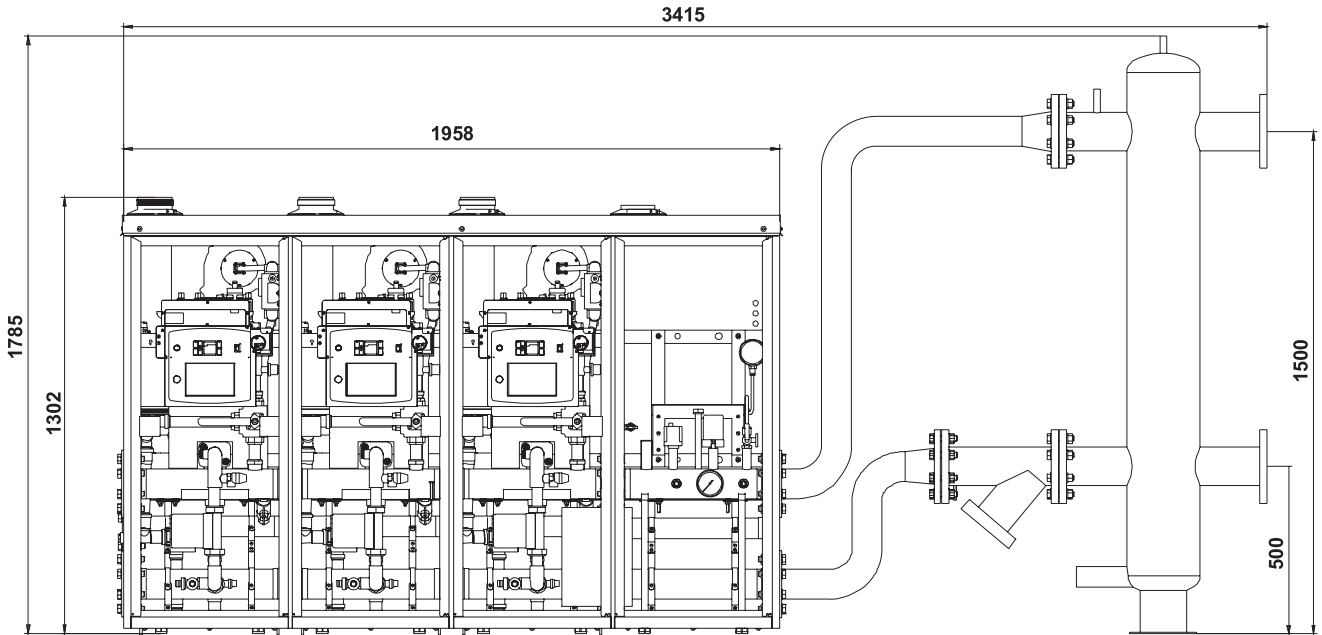

DIMENSIONS ALKON 90 in BATTERY (n.4 boilers) + KIT SAFETY DEVICES + HYDRAULIC HEADER + Y FILTER KIT

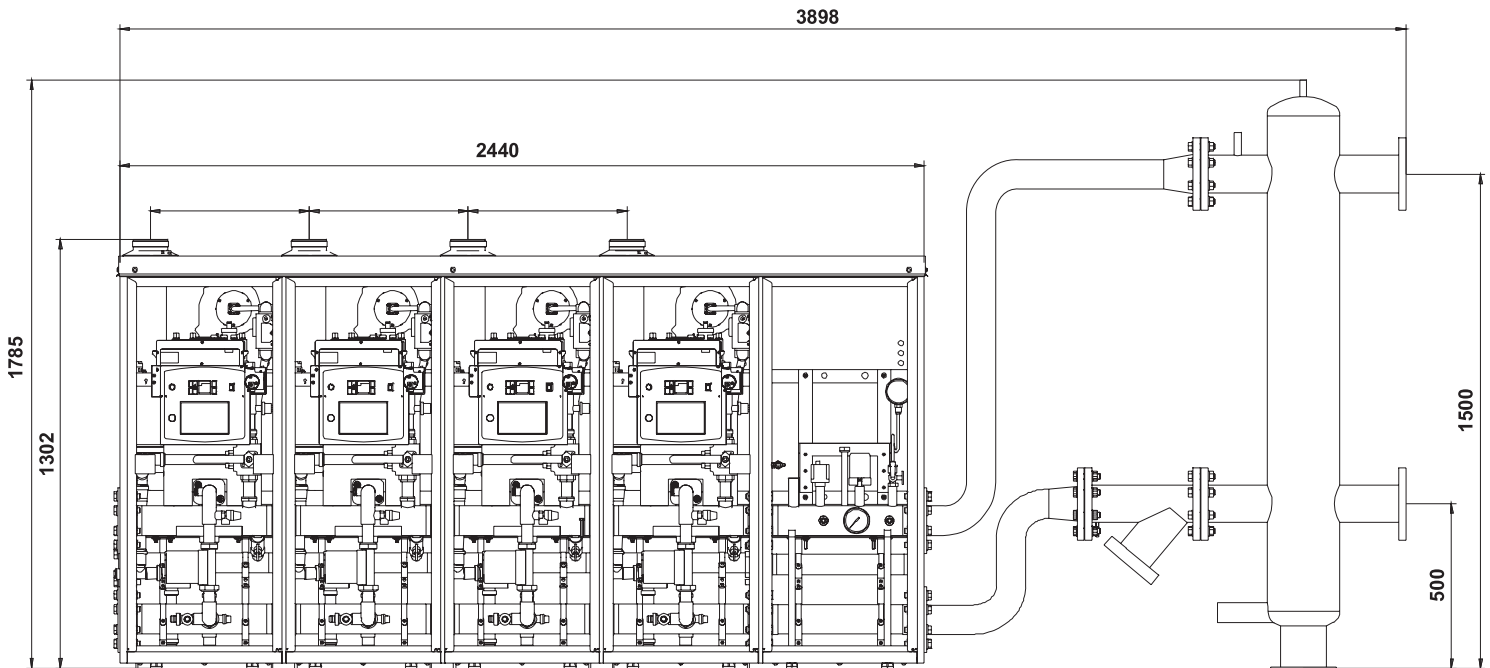

2.3 - MAIN COMPONENTS

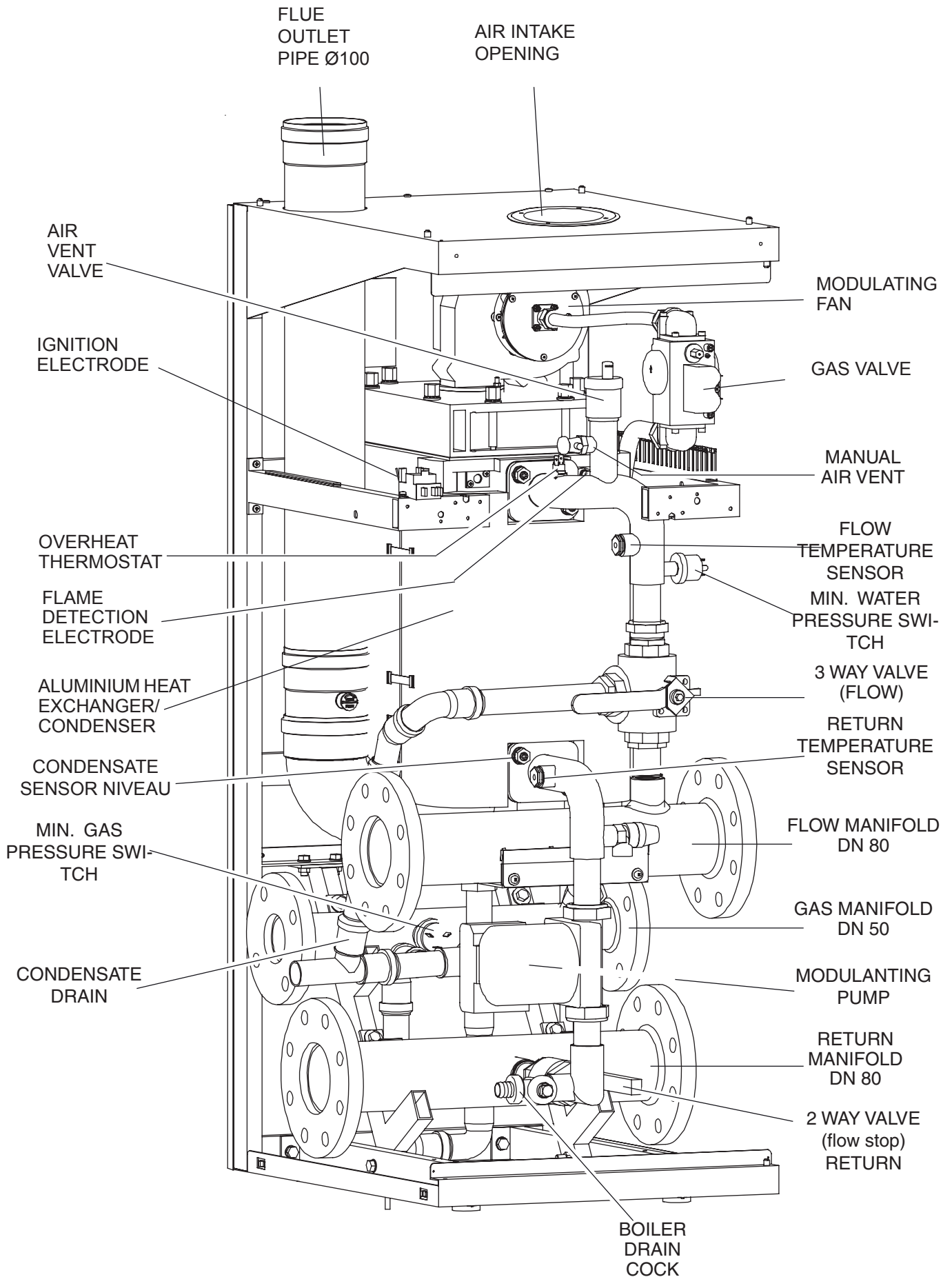

Technical features and dimensions

2.4 - BOILER WATER CIRCUIT DIAGRAM

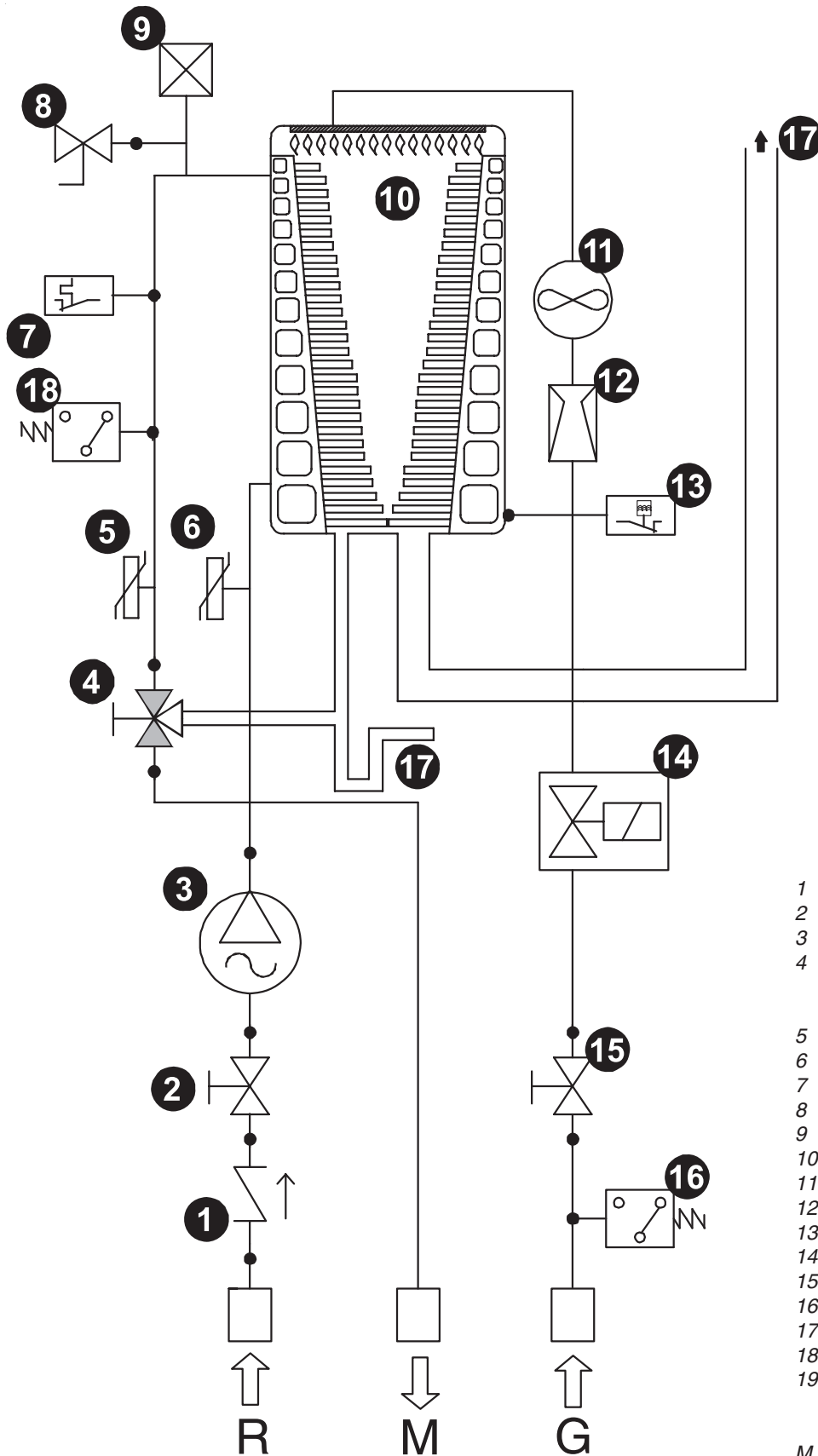

- 1 Non return valve
- 2 Return gate valve
- 3 Modulating pump
- 4 Flow gate valve (the way to the siphon is open in order to drain the boiler)
- 5 CH flow temperature sensor
- 6 CH return temperature sensor
- 7 Overheat thermostat
- 8 Manual air vent
- 9 Air vent valve
- 10 Heat exchanger
- 11 Fan
- 12 Premix
- 13 Condensate niveau sensor
- 14 Gas valve
- 15 Gas cock
- 16 Gas pressostat
- 17 Condensate drain siphon
- 18 Flue outlet
- 19 Pressure switch against lack of water

M C.H. flow
G Gas supply
R C.H. return

Technical features and dimensions



2.5 - PERFORMANCE DATA ACCORDING TO STANDARD UNI 10348

For information regarding the adjustment of: INJECTORS - BURNER PRESSURES – DIAPHRAGMS – OUTPUTS – GAS CONSUMPTIONS please refer to the paragraph ADAPTMENT TO THE USE OF OTHER GASES.

		BWA 90
Boiler category		II _{2H3P}
Modulation ratio		1 : 4,0
Rated heat output on P.C.I. Qn	kW	90
Minimum heat output on P.C.I. Qmin	kW	22
Rated useful power (Tr 60 / Tm 80 °C) Pn	kW	87,5
Minimum useful power (Tr 60 / Tm 80 °C) Pn min	kW	21,1
Rated useful power (Tr 30 / Tm 50 °C) Pcond	kW	93,6
Minimum useful power (Tr 30 / Tm 50 °C) Pcond min	kW	24,0
Rated power performance (Tr 60 / Tm 80°C)	%	97,26
Minimum power performance (Tr 60 / Tm 80°C)	%	96,02
Rated power performance (Tr 30 / Tm 50°C)	%	104,04
Minimum power performance (Tr 30 / Tm 50°C)	%	109,1
Performance at 30% of the load (Tr 30°C)	%	109,9
Combustion efficiency at nominal load	%	98,15
Combustion efficiency with reduced load	%	98,31
Casing heat loss with burner operating (Qmin)	%	2,29
Casing heat loss with burner operating (Qn)	%	0,90
Net flue gas temperature tf-ta (min)(**)	°C	32,8
Net flue gas temperature tf-ta (max)(**)	°C	38,5
Maximum permitted temperature	°C	100
Maximum operating temperature	°C	85
Flue gas mass flow rate (min)	kg/h	37,02
Flue gas mass flow rate (max)	kg/h	147,21
Excess air	%	25,53
Heat loss at chimney with burner on (min)	%	1,69
Heat loss at chimney with burner on (max)	%	1,85
Minimum heating circuit pressure	bar	0,5
Maximum heating circuit pressure	bar	6
Water content	l	10
Methane gas consumption G20 (pow.sup. 20 mbar) at Qn	m³/h	9,7
Methane gas consumption G20 (pow.sup. 20 mbar) at Qmin	m³/h	2,35
Gas consumption G25 (pow.sup. 20/25 mbar) at Qn	m³/h	11,07
Gas consumption G25 (pow.sup. 20/25 mbar) at Qmin	m³/h	2,71
Propane gas consumption (pow. sup. 37/50 mbar) at Qn	kg/h	6,99
Propane gas consumption (pow. sup. 37/50 mbar) at Qmin	kg/h	1,7
Chimney base maximum pressure available	Pa	100
Max condensate production	kg/h	14,5
Emissions		
CO at maximum heat output with 0% of O2	mg/kWh	107
NOx at maximum heat output with 0% of O2	mg/kWh	57
NOx Class		5
Electrical data		
Power supply voltage/frequency	V/Hz	230/50
Fuse on the power supply	A (R)	4
(**) Protection rating	IP	X5D
Room Temperature = 20°C		
(*) Temperature detected with appliance operation flow rate 80°C / ret. 60°C		
CO ₂ (min/max) See table "NOZZLES - PRESSURE"		
Seasonal space heating energy 2009/125 CEE (<=400Kw) ηs - see ErP table		
Stand-by heat loss ΔT 30°C - Pstb - see ErP table		
Consumption in stand-by - Psb - see ErP table		

Technical features and dimensions

2.4.1 - DATA ACCORDING TO ErP DIRECTIVE

			BWA 90
Description	Symbol	Unit	
Nominal Heat Output	P _{nominale}	kW	88
Seasonal space heating energy efficiency	η_s	%	94
Seasonal efficiency class in heating mode			A
For CH only and combination boilers: useful heat output			
Useful Heat Output in high-temperature regime (Tr 60 °C / Tm 80 °C)	P ₄	kW	87,53
Useful efficiency at nom. heat output in high-temperature regime (Tr 60 °C / Tm 80 °C)	η_4	%	87,6
Useful heat output at 30% of nom. heat output in low-temperature regime (Tr 30 °C)	P ₁	kW	29,7
Useful efficiency at 30% of nom. heat output in low-temperature regime (Tr 30 °C)	η_1	%	99,1
Range-rated boiler: YES / NO			NO
Auxiliary electricity consumption			
At full load	el _{max}	kW	0,290
At part load	el _{min}	kW	0,150
In stand-by mode	P _{SB}	kW	0,005
Other items			
Stand-by heat loss	P _{stb}	kW	0,211
Emissions of nitrogen oxides	NO _x	Mg/kWh	50
For CH & DHW production boilers			
Declared load profile			-
Energy efficiency in DHW production mode	η_{wh}	%	-
Daily electricity consumption	Q _{elec}	kWh	-
Daily fuel consumption	Q _{fuel}	kWh	-
Inside sound power level	L _{wa}	dB (A)	-
Seasonal efficiency class in DHW production mode			-

3

INSTRUCTIONS FOR THE INSTALLER

3.1 - GENERAL WARNINGS



WARNING!

This boiler has to be destined for the use for which it has been expressly designed for. Any other use shall be considered improper and therefore dangerous.

This boiler is designed to heat water at a temperature inferior to boiling point at an atmospheric pressure.



WARNING!

These appliances are exclusively designed to be installed inside adequate boiler rooms. Therefore these appliances must not be installed and operated externally. An outdoor installation could cause malfunctioning and could be dangerous. For external installations, it is recommended to use appliances which are specifically designed and predisposed for this purpose.



Before installing the boiler the following points have to be carried out by a competent engineer:

- a) The whole system should be thoroughly flushed in order to remove any residual dirt or grime which could compromise the correct boiler operation.
 - b) Check that the boiler has been preset for operating with the gas type available. This is verifiable via the indication on the packaging and on the data badge;
 - c) Check that the chimney/flue pipe has an adequate draught, does not have any constrictions, and that no other appliance's flue outlets have been fitted, unless the chimney is serving more than one heating appliance, according to the specific standards and regulations in force.
- The connection between the boiler and chimney/flue outlet can be made only after this verification has been carried out.



WARNING!

In rooms where there is the presence of aggressive vapours or dust the appliance must operate independently from the air present in the boiler's location room!



WARNING!

The appliance must be installed by a qualified engineer, who complies to the technical-professional requirements according to the law 46/90 and whom, under his own responsibility, guarantees the compliance of the standards according to the latest regulations.



WARNING!

The appliance must be installed only on a closed, vertical flat wall, made of non combustible material. The appliance must be positioned so that at least the minimum operational and servicing clearances are provided.



The boiler must be connected to a heating system which is compatible to its performance and output.

Instructions for the installer

3.2 - STANDARD CODES FOR INSTALLATION

The appliance must be installed in compliance to the instructions contained in this manual.

The installation must be carried out by a competent qualified engineer, whom will assume the responsibility of complying to all the local and/or national regulations published in the official publications, as well as all the applicable codes of practice.

Before installing the appliance please contact the gas supply company.

The installation must be carried in accordance to the codes of practice, the regulations and the requirements hereby indicated which constitute an indicative list, but not a complete one, as these continue to undergo evolve developments.

National installation regulations:

Gas plants for domestic use fed by network distribution
Standard UNI-CIG 7129

Gas plants for domestic use not fed by network distribution
Standard UNI-CIG 7131

Law dated 5.03.90 n°46

Law dated 9.01.91 n°10

Other applicable statutory requirements:

Law 1083/71 (ref. Standard UNI for the design, installation and maintenance).

Law 46/90 and D.P.R. 447/91

Law 10/91 and D.P.R. 412/93 and subsequent amendments
D.M 1.12.1975

Moreover, the boiler must be installed in accordance to all the regulations regarding the boiler room, the building regulations and the prescriptions regarding central heating plants in force in the country the boiler is installed.

The appliance must be installed, commissioned and serviced according to the regulations in force. This is also valid for the hydraulic system, the flue outlet system and the boiler location room.

3.3 - PACKAGING

The BWA 90 boiler is supplied fully assembled in a strong cardboard box.



After having unpacked the boiler check that it is intact and undamaged.



Keep the packaging material (cardboard box, plastic bags, polyester protection etc.) **out of the reach of children as they can be dangerous.** The Manufacturer refuses all liability for injury to persons, animals or damage to property deriving from not having respected the above mentioned recommendations.

In the packaging, in addition to the boiler, you can also find the following contents:

- Service logbook
- Instruction manual for the person in charge of the appliance
- Instruction manual for the installer and servicing personnel
- Warranty
- Nr. 2 spare parts request coupons



Envelope with adjustable feet, lock and key (placed on the pallet, inside the boiler).

Remove the "A" to remove the boiler from pallet.

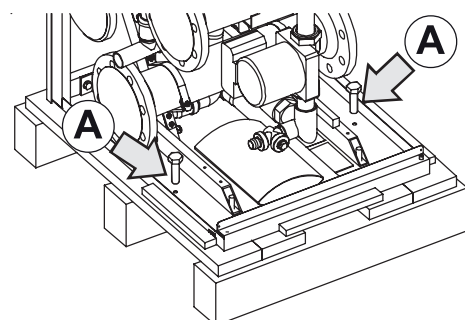
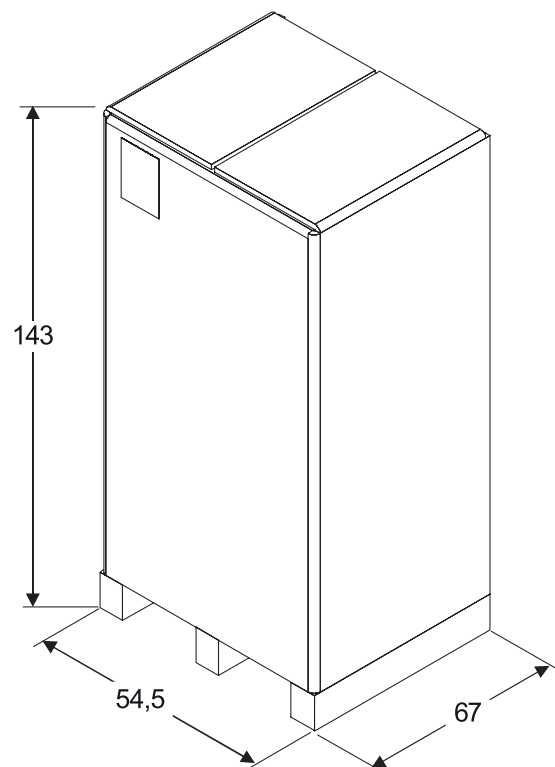

3.4 - LOCATION OF BOILER INSIDE A BOILER ROOM

The boiler must be installed in accordance with the directions indicated in the most recent Standards and legislations regarding boiler rooms, installation of heating and hot water systems, boiler ventilation, chimney's capable of discharging the products of combustion of condensing boilers and any other applicable requirement.

The boiler will be placed on a flat and sufficiently strong base-ment,, with dimensions not smaller than the ones of the boiler. After installation the boiler will result perfectly horizontal and very stable (in order to reduce vibrations and noise).

Installation

When choosing the installation place, the following items have to be considered:

- To grant an easy access to the boiler components in order to facilitate the ordinary and extraordinary service operations.
- The floor should not be of flammable material.
- If the floor is flammable an insulation material, with the capacity to withstand to the fire for at least 120 min should be placed between the boiler and the floor and will protrude de boiler basement of 0.5 m all around.

Mounting of the adjustable feet

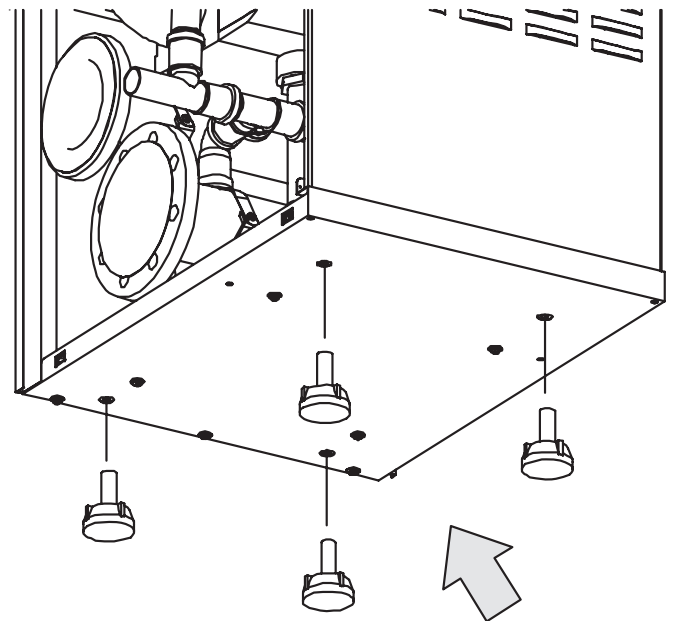

Before positioning the boiler, screw down the adjustable feet supplied with the boiler.

Mounting of the locker



The casing front panel is hinged on the R.H. side. The hinges "A" are factory fitted on the R.H. side of the frame. For the introduction of the cocker remove the precut disk "B" with a screwdriver and fit the cocker as shown in the figure.

In case the casing front panel needs to be hinged on the L.H. side, deplace the hinges "A" from R.H. to L.H. side; then remove the precut disk "C" from the front panel and fit the locker as shown in the figure.

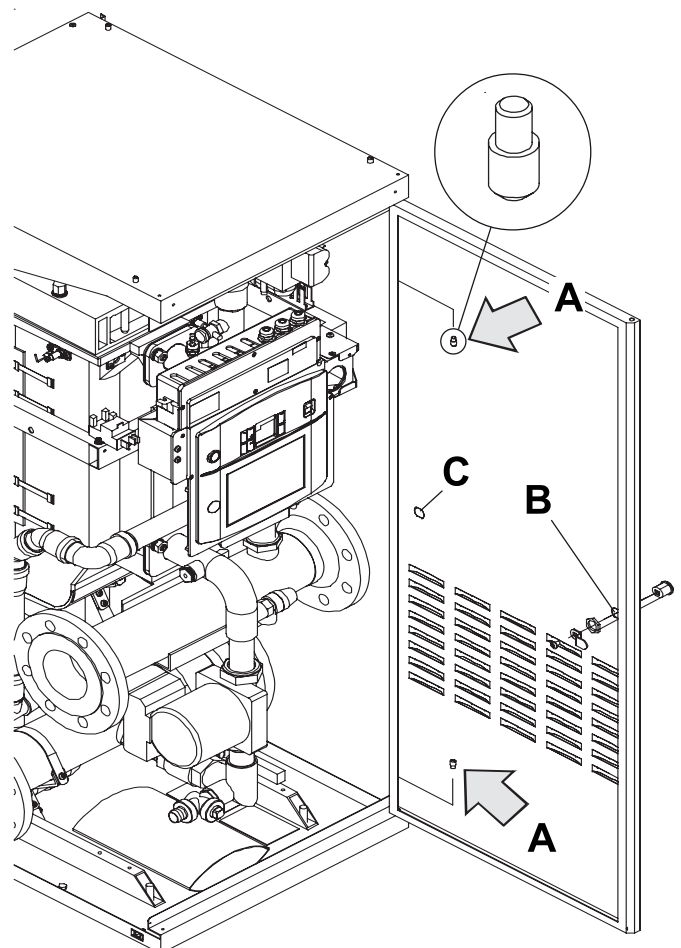
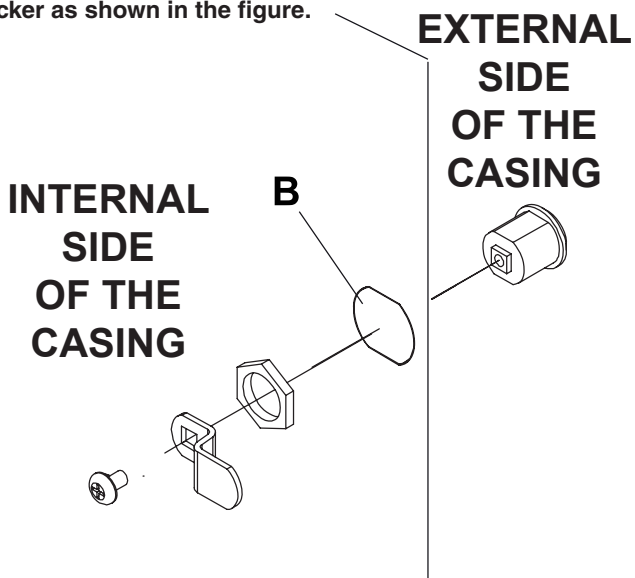

Instructions for the installer

3.5 - INSTALLATION ON EXISTING HEATING SYSTEMS

When the appliance is installed on existing systems, ensure yourself that:

- The flue outlet pipe is suitable for condensing boilers, for the temperature of the products of combustion, calculated and manufactured according to the regulations in force. It must be installed as much as possible in a straight line, tested for soundness, insulated and must not have any occlusions or restrictions.
- The flue outlet pipe has a connection for the discharge of condensate.

- The boiler room has a suitable outlet for the discharge of condensate produce by the boiler.
- The electrical system has been fitted in compliance to the specific norms and the work has been carried out by a competent person.
- The circulation pump's output, the head and flow direction are suitable.
- The gas feeding supply pipe and the eventual tank are constructed according to the regulations in force.
- The expansion vessels assure the total absorption of the dilatation of the fluid contained in the system.
- The system has been cleaned of impurities and lime scale.

3.6 - GAS CONNECTION

The gas supply pipe must be connected to the boiler via the respective pipe connection $\frac{3}{4}$ " as indicated on page 13.

The gas supply pipe must have a section which is identical or greater then the one used on the boiler and must assure a correct gas pressure.

It is however important to comply with the specific norms and requirements in force, foreseeing on-off valves, gas filter, anti-vibrating joint etc.

Before commissioning an internal gas distribution system and therefore before connecting it to the gas meter, the complete installation must be tested for gas soundness.

If any part of the system is concealed from view the gas soundness test must be carried out before covering the pipes.



DANGER!

The gas connection must be carried out by a registered engineer who will have to respect and comply to the regulations in force and to the requirements indicated by the local gas supplier. An incorrect installation could cause injury to persons, animals or damage to property. The manufacturer shall not be held liable for any injury and/or damage.



Before installing the boiler it is recommended to thoroughly clean all the supply piping in order to remove any eventual residual grime which could compromise the boilers correct functioning.



If you smell gas:

- Do not turn on or off electrical switches, use the telephone or any other object which can provoke sparks;
- Open all doors and windows in order to allow fresh air to enter and purify the room;
- Close all gas cocks
- Contact a service engineer, qualified installer or the gas supply company.



As a safety measure against gas leaks, The Manufacturer recommends installing a surveillance and protective system made up of a gas leakage detector combined with an on-off selenoid valve on the gas supply line.

EXAMPLE OF A GAS SUPPLY SYSTEM

1. On-off gas supply valve
2. Double membrane regulator
3. Gas filter
4. Anti-vibrating joint
5. Selenoid valve
6. On-off cock

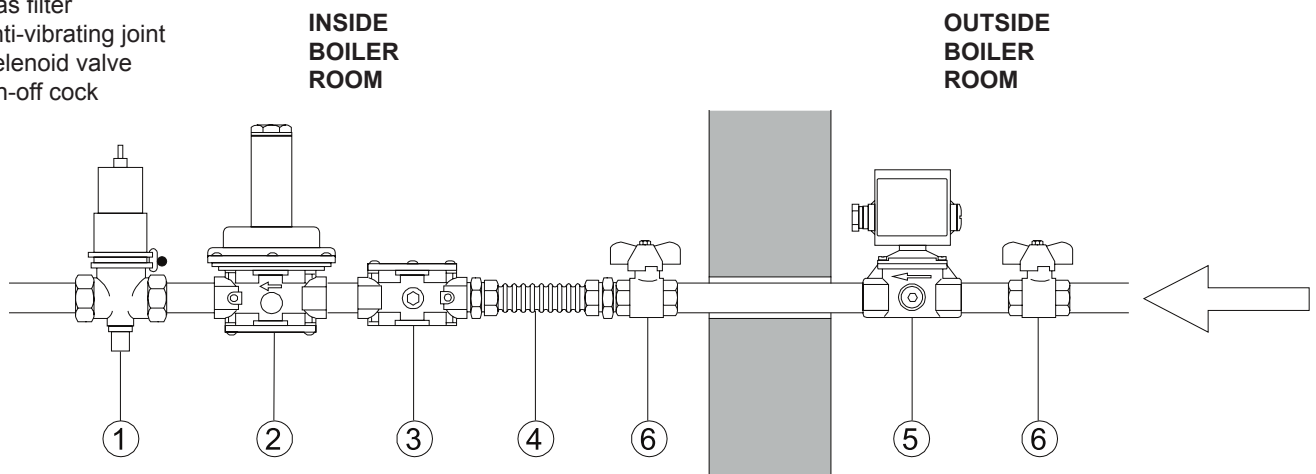

3.7 - FLOW AND RETURN PIPE CONNECTIONS

The CH flow and return circuits have to be connected to the boiler via the respective connections 3" M and R (DN 80) as indicated on page 8.

When determining the size of the CH circuit pipes it is essential to bear in mind the pressure losses induced by any of the system's components and by the configuration of the same system.

The route of the piping has to be conceived taking all the necessary precautions in order to avoid air locks and to facilitate the continuous purging of the system.

Non-observance of these instructions could cause injury to persons, animals or damage to property. The manufacturer shall not be held liable for any such injury and/or damage.



Ensure yourself that the system's piping is not used as the earth clamps for the electrical or telephonic system. They are absolutely unsuitable for this use. In a short time this could cause serious damage to the piping, boiler and radiators.



WARNING!

Before installing the boiler we recommend that the system is flushed out with a suitable product in compliance to the norm UNI-CTI 8065, in order to eliminate any metallic tooling or welding residues, oil and grime which could reach the boiler and affect the proper running of the boiler.



WARNING!

IT IS ABSOLUTELY FORBIDDEN TO FIT ON-OFF VALVES ON THE GENERATOR TO THE FORE OF THE SAFETY DEVICES

WATER SIDE PRESSURE LOSSES

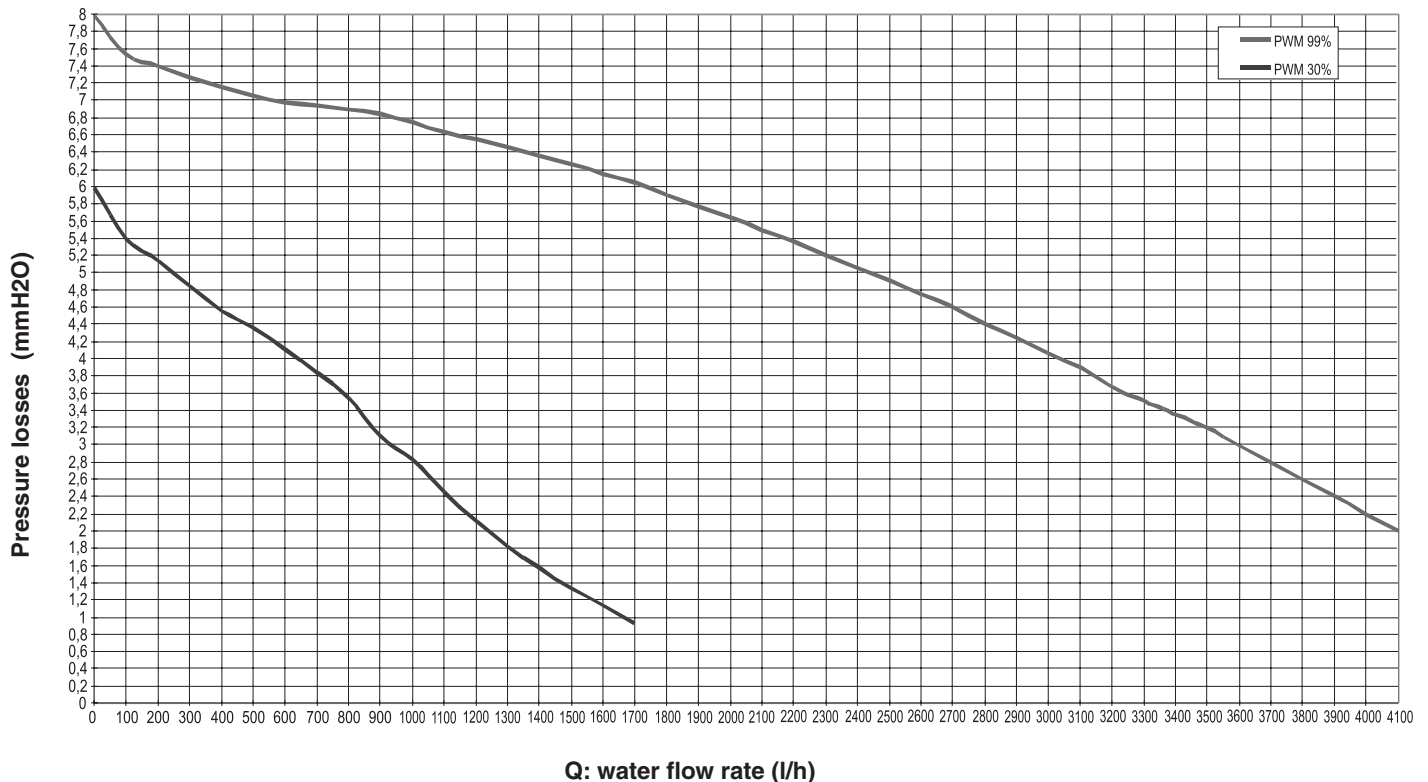

EXAMPLE:

For a ΔT 15K the max. water flow rate demanded is 2849 l/h.

From the graph of the boiler's pressure losses it can be determined that the pump must be able to guarantee a head of at least 3,1 mH₂O.

Instructions for the installer

3.10 - SUPPLEMENTAL SAFETY, PROTECTIVE AND CONTROL DEVICES PRESCRIBED BY THE GOVERNMENT DECREE 01-12-1975 AND RELATIVE APPLICABLE TECHNICAL SPECIFICATIONS (CONTAINED IN THE “RACCOLTA R EDITION 1982”)

CERTIFICATION OF THE SUPPLEMENTAL SAFETY DEVICES:

Several notified bodies prescribe supplemental safety devices. For the safety valves and on-off gas valves it is necessary to obtain the ISPESL (Institution for preventive measures and safety at work) calibration certificate which confirms that they are free from lead or bossing.

The expansion vessels with a capacity superior to 24 litres must have been supplied with an approval booklet released by ISPESL and a manufacturer's conformity declaration.

All the accessories must have an ISPESL approval certificate.

SAFETY DEVICES

1. On-off gas valve: a device which has the function of cutting off the gas supply when the water temperature reaches the max. predetermined value. The sensible element has to be installed as nearest as possible to the generator (flow pipe) at a distance which has to be < 500 mm and must not be able to be cut-off.

2. Pressure relief valve: it has the function of discharging in the atmosphere the fluid contained in the generator when this has, for whatever motive, reached the maximum working pressure.

PROTECTIVE DEVICES

3. Overheat thermostat: it has the function of shutting down the generator if the safety thermostat fitted in the boiler malfunctions. It must be calibrated to a value of < 100°C, which MUST not be changed.

4. Safety pressure switch: it has the function of shutting down

the generator if it reaches the maximum working pressure. It must be able to be reset manually.

CONTROL DEVICES

5. Pressure indicator with shock absorber tube and pressure gauge holder valve: it indicates the effective pressure existing in the generator. It must be graduated in “bar” and must have the maximum operating pressure in scale and be equipped with a 3-way valve with the connection for the manometer.

6. Thermometer: it indicates the effective water temperature contained in the generator. It must be graduated in degrees Celsius with a temperature scale not exceeding 120°C.

7. Inspection pocket: approved for inserting the control thermometer

8. Calibrated expansion vessel: it permits the absorption of the increase in volume of the system's water following an increase in temperature; the boiling point (ISPESL) must not be superior to the pressure relief valve's calibrated pressure.

3.11 - PRESSURE RELIEF VALVE DRAIN PIPE



A pressure relief valve must be fitted on the flow pipe, within 0,5 m from the boiler. It must be dimensioned for the capacity of the boiler and must comply to the regulations in force,



WARNING!

Please remember that it is forbidden to interpose, between the boiler and the pressure relief valve, any type of cutting-off device. Moreover it is recommended to use cutting-off valves which do not exceed the maximum allowable operating pressure.



WARNING!

In correspondence to the heating pressure relief valve foresee the installation of a discharge pipe with a funnel and a siphon which lead to an adequate drainage. The drainage has to be controllable by sight.

If this precaution is not made, an eventual intervention of the pressure relief valve could cause injury to persons, animals or damage to property. The manufacturer shall not be held liable for any injury and/or damage.

3.12 - WORKING PRESSURE

The boiler's maximum allowable working pressure is set at 3 bar; whilst the minimum pressure is pre-charged to 0,5 bar.



WARNING!

The boiler does not have any specific protective device against water loss, as this function is carried out promptly by the overheat thermostat. However, on the boiler's electronic board, the possibility of connection to a minimum pressure switch is foreseen..

Instructions for the installer

3.11 - MIXING HEADER FILTER



The Manufacturer suggests the installation of a Y filter on the return pipe so that it can be cleaned if necessary. This filter will protect the boiler from the heating system dirt.

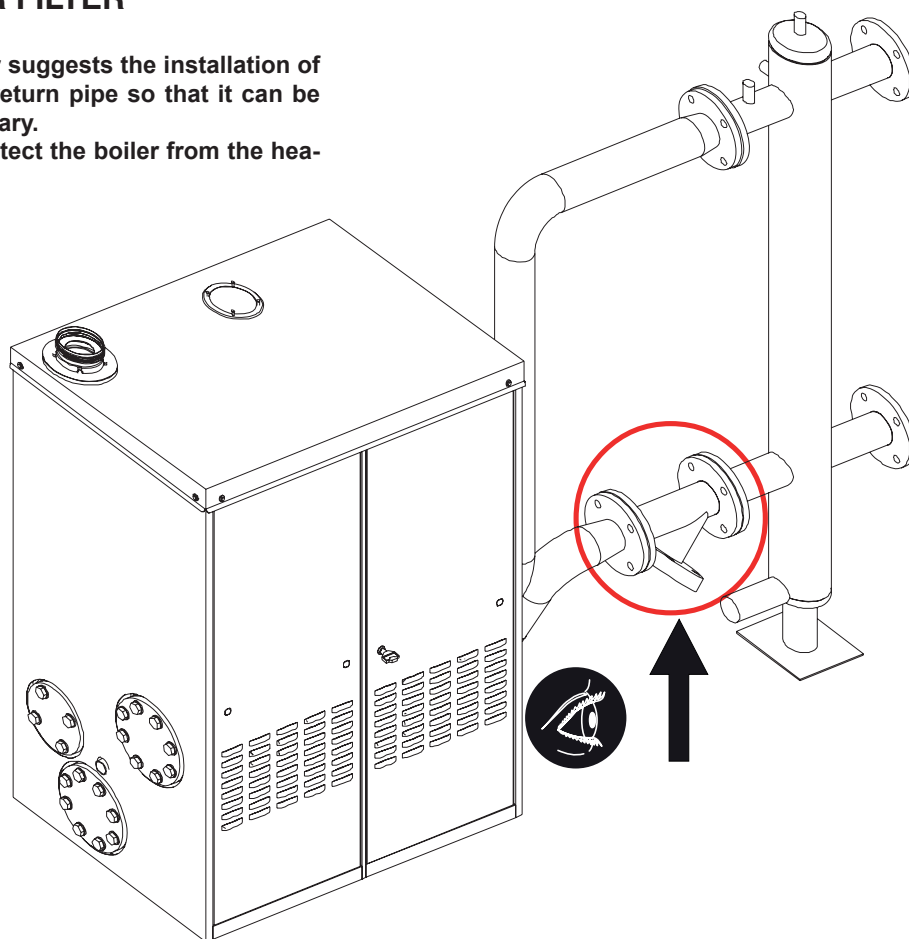

3.12 - MIXING HEADER

In order to ensure correct boiler operation it is necessary to use a mixing header which guarantees:

- the separation and collection of circuit dirt
- optimal air venting
- hydraulic de-coupling of the two hydraulic circulation circuits
- balancing of the circuits

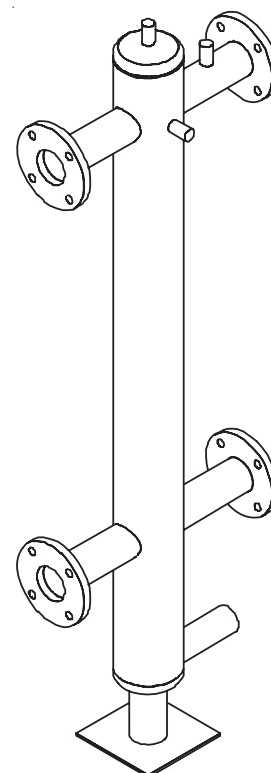

3.13 - CONDENSATE DRAIN

During the combustion process the boiler produces condensate which, through the "A" pipe, flows into the siphon. The condensate which forms inside the boiler has to be routed into an adequate drain by means of the pipe "B".



DANGER!
Before commissioning the appliance fill the siphon through the filling pipe "C" and check the correct drainage of the condensate.
If the appliance is used with the condensate drain siphon empty there could be danger of intoxication resulting from the escape of gas fumes.

The connection between the appliance and the sewage system must be carried out in compliance with the specific norms, and in particular:

- prevent the end user utilizing the condensate produced
- it must be fitted with a siphon (supplied with the boiler)
- it must be fitted without any bottlenecks;
- it must be installed so as to avoid freezing of the liquid when the boiler is operating and prevent the eventual pressurization of the sewage system;
- consent the correct downflow of the appliances liquid discharges;
- it must be made with one of the following materials which are resistant to condensate:
 - Grès, according to the Standards DIN 1230-1 and 6, EN 295-1 or 2 or 3
 - Glass (boron silicate)
 - Polyvinyl chloride (PVC), according to DIN V 19534-1 and 2, and DIN 19538
 - Polyethylene (PE) DH type, according to DIN 19535-1 and 2 and DIN 19537-1 and 2
 - Polypropylene (PP) and copolymer styrene (ABS) according to DIN V 19561
 - Polyesterific resin (GF-UP), according to DIN 19565-1
- Stainless steel

A Boiler condensate inlet

B Condensate outlet, pipe to connect to the sewage system

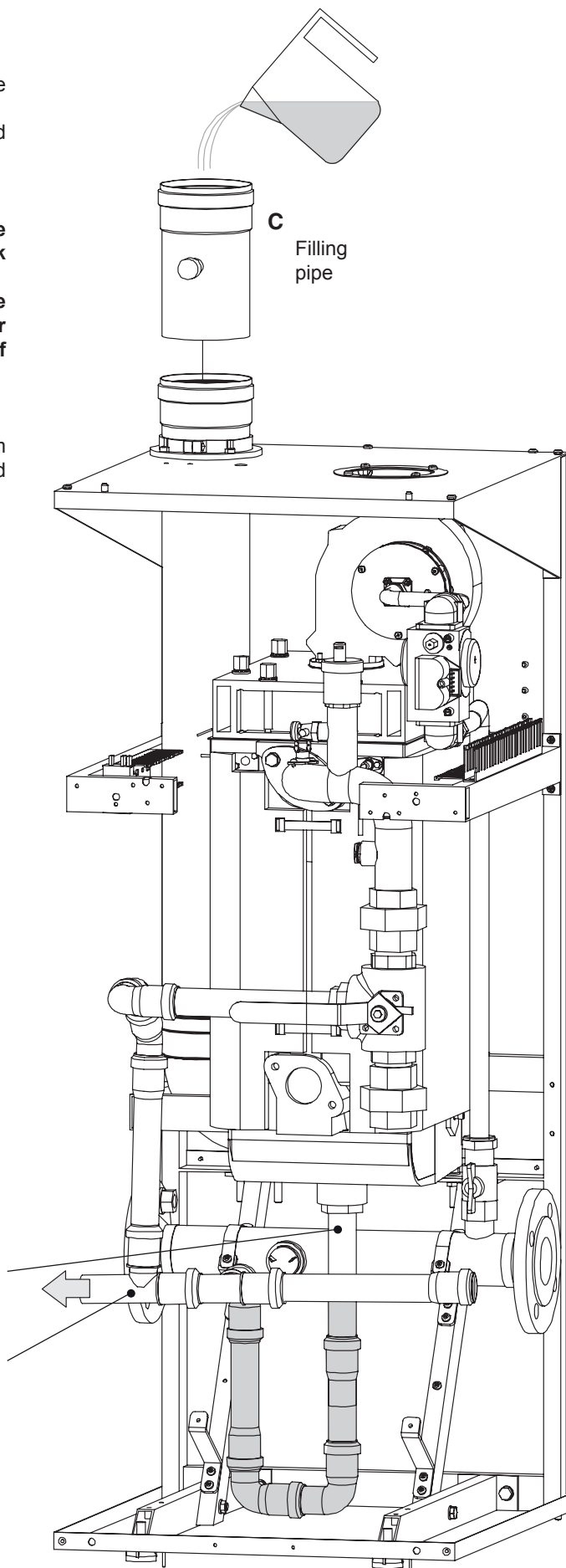

Instructions for the installer

3.14 - WATER TREATMENT

The chemical/physical features of the heating system's water are fundamental for the boiler's correct operation and safety.

Infact the Standards indicated here below foresee a preventive treatment before placing water inside the CH circuit.

Reference standards:

UNI CTI 8065/1989 "Water treatment in thermal heating systems for civil use"

UNI CTI 8364/1984 " Heating systems – Control and maintenance"

The scope of this treatment is finalized for eliminating or substantially reducing the following problems:

- lime scale deposit
- corrosion sludge
- deposits
- microbiological growths (moulds, bacteria etc.)

An appropriate treatment of the supply water will prevent the above stated problems and will maintain the correct operation and efficiency of the generator in time.

For this purpose it will be necessary to fix the following chemical-physical characteristics of the water:

PH include between 6,5 and 8
Hardness 15° FR

Therefore, before filling the heating system it will be necessary to fit the devices indicated in the figure.



THE INSTALLATION MUST BE FORESEEN ON THE RETURN PIPE OF THE PRIMARY CIRCUIT DOWNSTREAM OF THE CIRCULATING PUMP.

All necessary precautions must be taken for preventing the formation and localization of oxygen in the system's water. For this reason, ensure yourself that the plastic piping used in underfloor heating systems is impermeable to oxygen.

If any anti-freeze solutions are used ensure that they are compatible with aluminium and any other boiler components and materials.



WARNING!

Any damage caused to the boiler due to the formation of lime scale or by corrosive water will not be covered by the warranty.

EXAMPLE OF SCALE REDUCING DEVICE CONNECTION FOR WATER TREATMENT

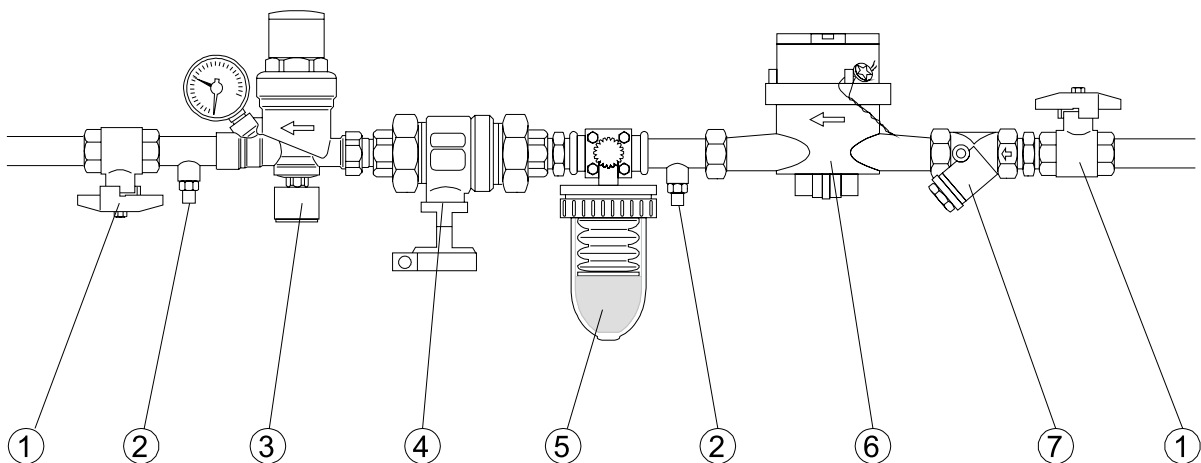

1. Ball valve
2. Inspection pocket
3. Filling-up group
4. Disconnecter
5. Scale reducing device
6. Litrecounter (recommended)
7. "Y" filter

3.15 - FLUE INSTALLATION

The flue system must be installed in accordance with the local and national Standards (refer to UNI 13384-1-2)
The flue outlet must be made only with material resistant to products of combustion, pertaining to class W1 according to UNI EN 1443, and as a rule made in stainless steel or plastic material.



We recommend using only original flue outlet systems.
Damages caused by installation errors and for non-observance of the instructions given by the same manufacturer will invalidate all the supplier's contractual or extra contractual responsibilities.

The boiler has been approved for the following flue configurations:

Type B23

Boiler designed to be connected to an open flue which will terminate vertically through the roof. The combustion air is intaken directly from the room where the boiler is installed.

WARNING: for this type of connection the room must comply with the same installation regulations valid for open chimney boilers.
The chimney must comply to the current regulations.

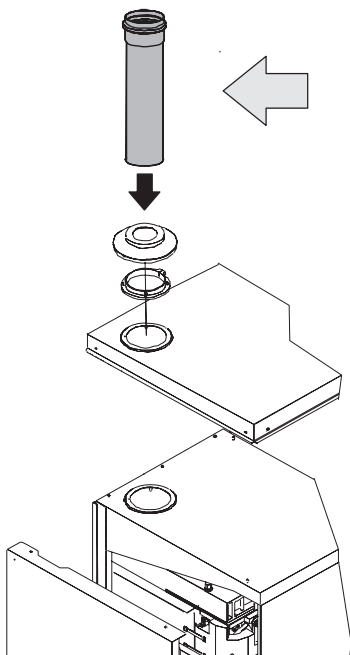
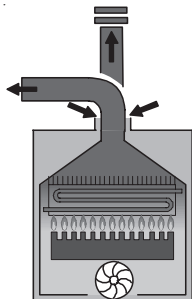

Preliminary operations:

- Fit the flue outlet pipe \varnothing 100mm, supplied in the packaging, as indicated in the figure.

FLUE OUTLETS \varnothing 100 mm Type B23



The maximum total horizontal run permitted by the \varnothing 100mm outlet and intake pipe is 30 m inclusive of 1 wide radius bend and 1 flue outlet terminal.

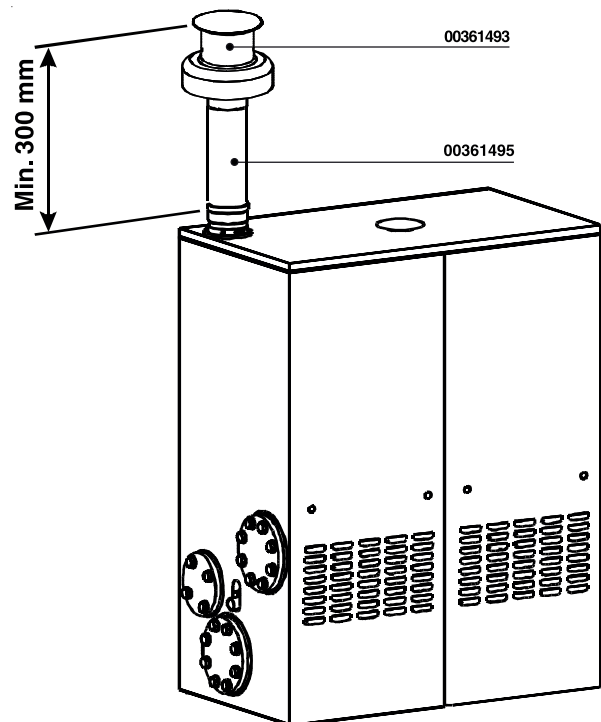
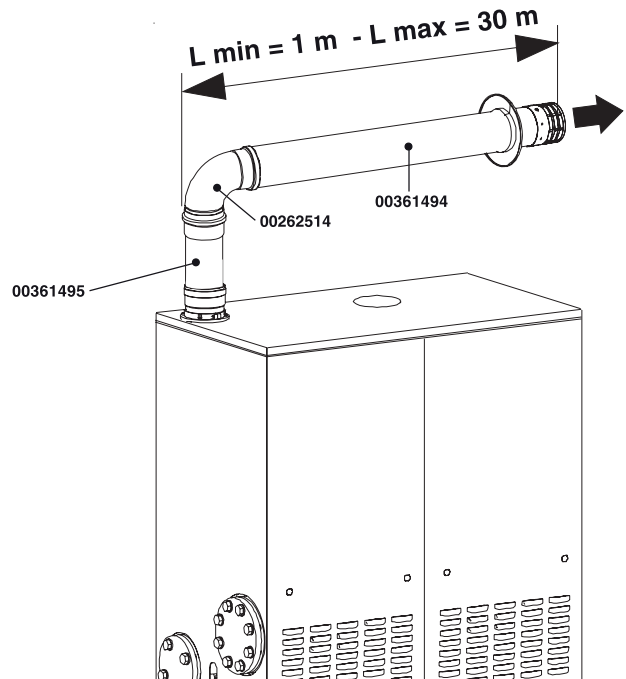

3.16 - ELECTRICAL CONNECTIONS

Regulations in force

The gas and water feeding pipes and the CH system pipes cannot be used as ground plates.

Ensure that the above safety electrical requirements subsist; in case of doubt, ask for a professionally qualified technician to check the appliance's electrical system.

The Manufacturer refuses responsibility for any damages arising from failure to earth the boiler correctly.

It is necessary that a qualified technician verifies that the electrical system is adequate to the appliance's maximum absorbed power, indicated on the data plate, verifying in particular that the section of the system's cables is suitable to the appliance's maximum absorbed power.

For the appliance's general electrical supply the use of adaptors, multiple sockets and/or extension cords is strictly forbidden.

The use of any power supplied equipment implies the observance of several fundamental rules, such as:

- Do not touch the appliance with any wet part of your body and/or barefooted;
- Do not pull the supply cables
- Do not expose the boiler to sunlight, rain, etc., unless it is explicitly foreseen;
- Do not permit children or inexperienced people to use the appliance.

Mains electrical supply connection 230V

The boiler is provided complete with a mains supply cable 1,5 m long and with a cross section area of 3x0,75 mm².

The electric connections of the boiler are shown in the section named "WIRING DIAGRAMS" (paragraph 3.17 page 26)

A mains supply of 230 V – 50 Hz is required. The wiring to the boiler must be in accordance with the current CEI regulations.



WARNING!

We remind you that upstream of the electrical connection, it will be necessary to foresee a service relay (NOT SUPPLIED) which, when the electrical safety devices (ISPESL) intervene, shuts down the electrical supply to the on-off fuel valve fitted on the gas supply circuit, but not to the boiler so as to guarantee the running of the pump and permit the boiler to cool down.



DANGER!

The electrical connections must be carried out only by a qualified engineer. Before carrying out the connections or any other operation on the electrical parts, always switch off and disconnect the electricity supply and ensure yourself that it cannot be accidentally turned on.

It is necessary to fit a double pole switch on the electrical supply line, having a 3 mm contact separation in both poles, in an easy accessible position in order to make quick and safe the servicing operations.

Room thermostat and/or E8 heating controller connection



DANGER!
Switch off and disconnect the electricity supply before carrying out any operations on the electrical parts.

**TA
ON-OFF**

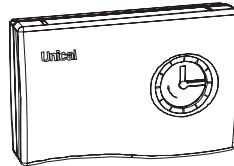

E8

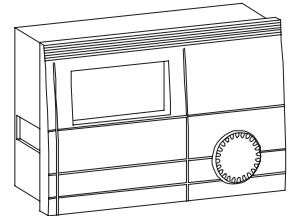

- Gain access to the Y1 terminal board
- For the **Room thermostat** connection 1 and 2 and connect them to the thermostat's cables.
- For the **Heating Controller** connection use the connecting terminals 3 and 4.

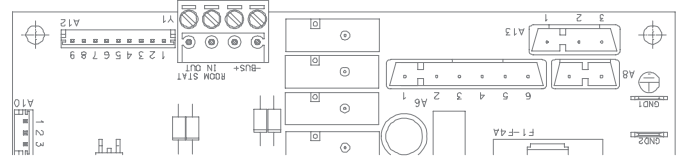

Connection of the additional safety devices



DANGER!
Switch off and disconnect the electricity supply before carrying out any operations on the electrical parts.

For the connection remove the existing jumper.

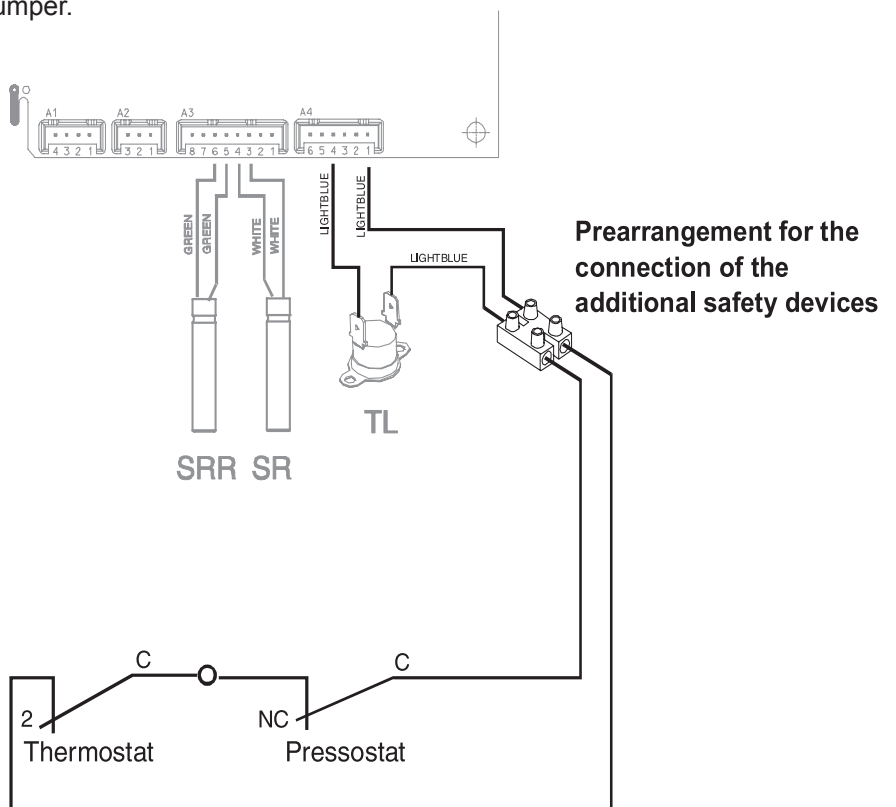
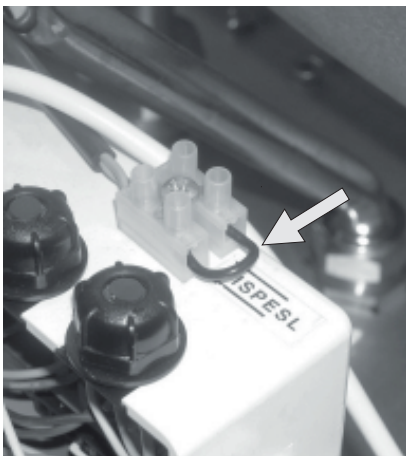

Instructions for the installer

Connection of the additional safety devices for BWA 90 in battery



DANGER!
Switch off and disconnect the electricity supply before carrying out any operations on the electrical parts.

For the connection remove the existing jumper.

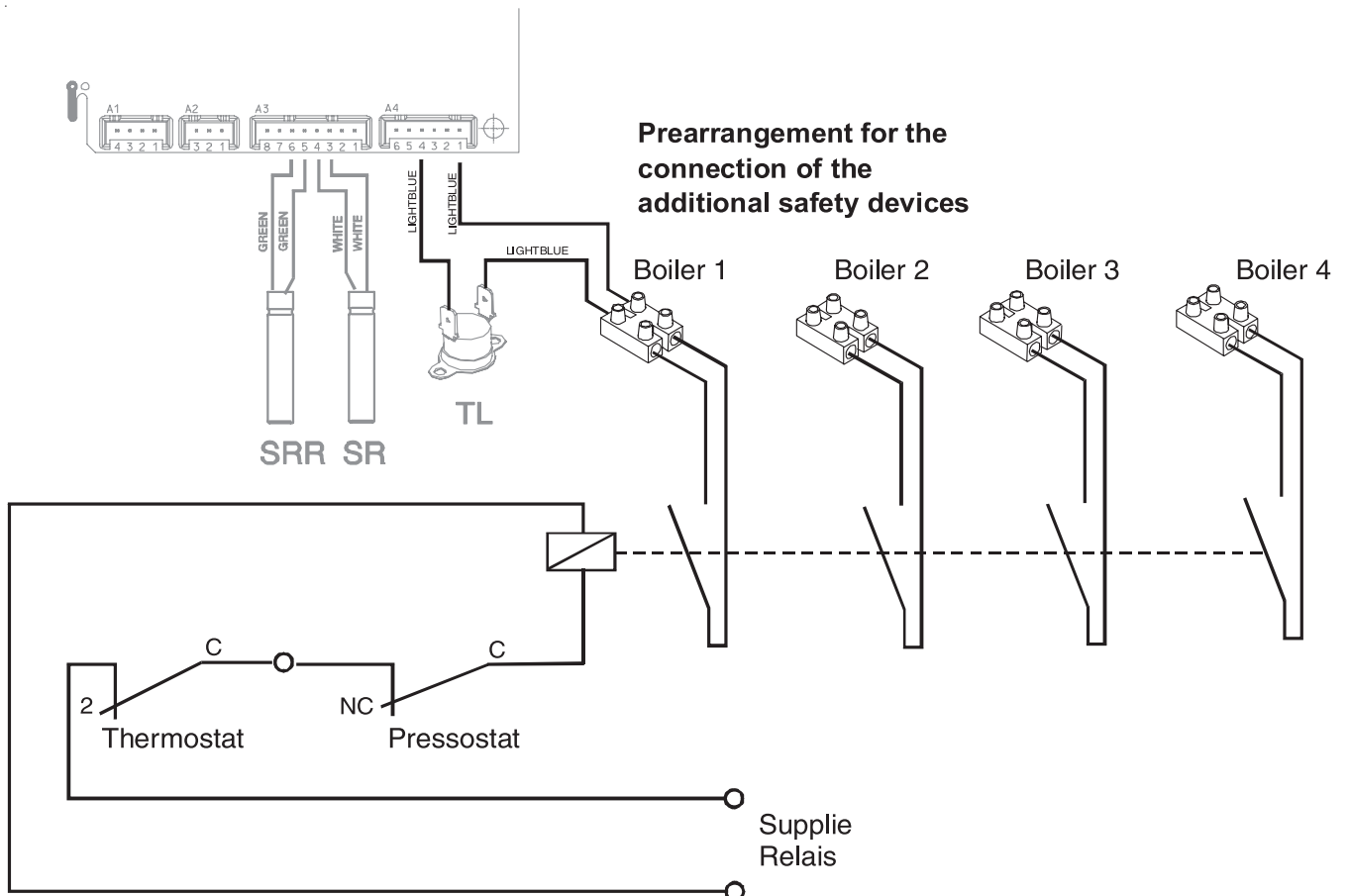
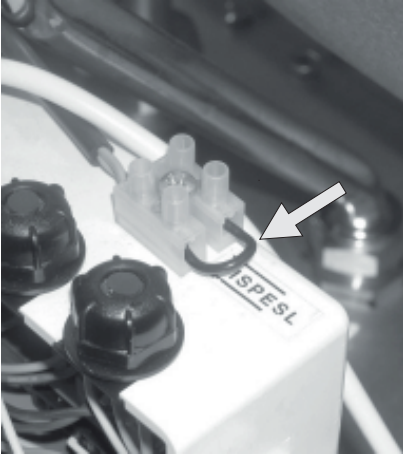

3.17 - FUNCTIONAL FLOW WIRING DIAGRAM

- DK = Minimum water pressure switch
- E. ACC = Ignition electrode
- E. RIV = Detection electrode
- PG = Gas pressostat
- PM = Modulating pump
- SR = CH sensor
- SRR = CH return sensor
- SL = Condensate level sensor
- TE = Flue-gas spillage thermostat (optional)
- TL = Limit thermostat
- VG = Gas valve
- VM = Modulating fan detection/adjustment

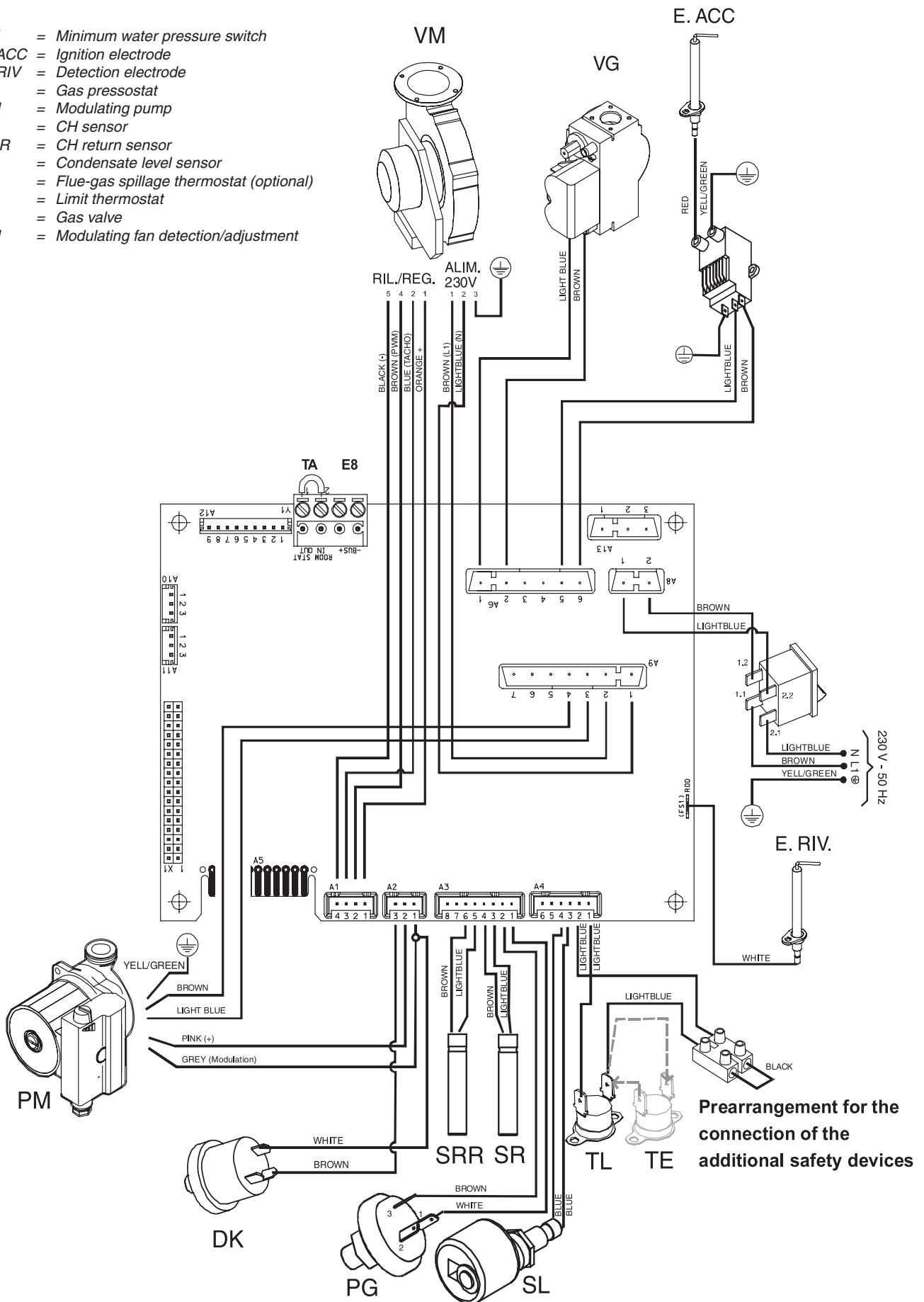

Instructions for the installer

3.18 - WIRING DIAGRAM FOR CONNECTIONS AND MANAGING

On the back side of the E8 regulator there are two terminal blocks, of which one is for the mains (230 V) connections and the other one is for the low tension connections.

The main controls, necessary for the C.H. system management and for the boiler control, as well some components which are part of the boiler house, must be connected to the terminal blocks.

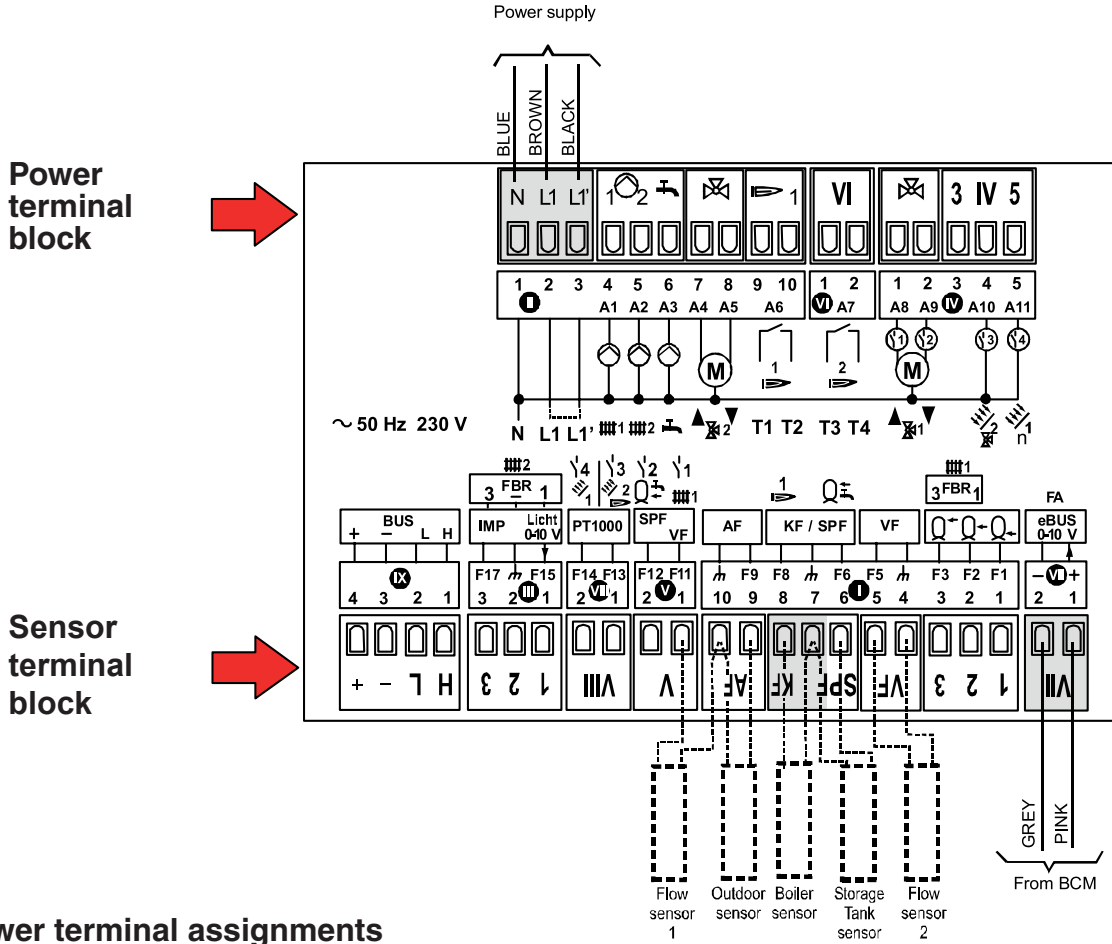

Power terminal assignments

Terminal II

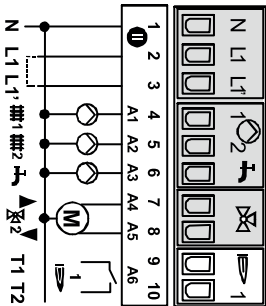

- N: Neutral conductor, mains
- L1: Power supply, unit
- L2: Power supply to relay
- ##1: heating circuit pump HK 1
- ##2: heating circuit pump HK 2
- ⚡: Storage tank charging pump
- ⊗2▲: Mixer open, heating circuit 2
- ⊗2▼: Mixer closed, heating circuit 2

Terminal VI

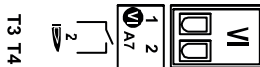

Terminal IV

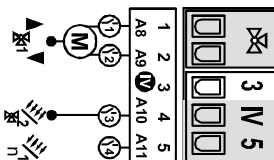

- ⊗1▲: Mixer open, heating circuit 1
- ⊗1▼: Mixer closed, heating circuit 1
- Multifunction relay
- Recycle pump / Multifunction relay

Sensor terminal assignments

Terminal VII Connection to BCM

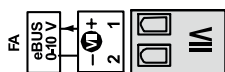

Pin 1: eBUS (FA) or 0-10V output
Pin 2: (Ground)

Terminal I

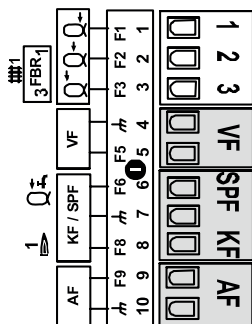

Pin 1: Buffer storage tank low sensor
Pin 2: Buf. stor. tank middle sensor / FBR heat. circ. 1 (room sensor)
Pin 3: Buf. stor. tank top sensor / FBR heat. circ. 1 (set value)
Pin 4: VF Pin 4: Flow sensor, heating circuit 2 (ground)
Pin 5: VF Pin 5: Flow sensor, heating circuit 2
Pin 6: SPF Pin 6: Storage tank sensor
Pin 7: SPF Pin 7: Storage tank and boiler sensor (ground)
Pin 8: KF Pin 8: Boiler sensor
Pin 9: AF Pin 9: Outdoor sensor
Pin 10: AF Pin 10: Outdoor sensor (ground)

Terminal V

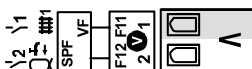

Pin 1: VF Pin 1: Flow sensor heating circuit 1 / sensor multifunction 1
Pin 2: SPF Pin 2: Service water low sensor / sensor multifunction 2

Terminal VIII

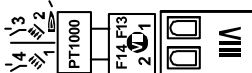

Pin 1: F13 Pin 1: Sensor HS2 / Solar 2 / Multifunction relay 3
Pin 2: F14 Pin 2: Sensor Solar 1 / Sensor multifunction relay 4

Terminal III

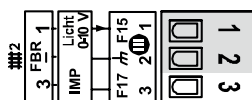

Pin 1: F15 Pin 1: FBR heating circuit 2 (room sensor) / 0-10V IN / Light
Pin 2: Pin 2: FBR heating circuit 2 (ground)
Pin 3: F17 Pin 3: FBR heating circuit 2 (set value) / Pulse counter for

Morsetto IX For connection to remote control devices

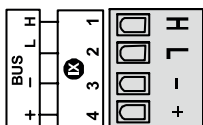

Pin 1: H CAN Bus Pin 1 = H (Data)
Pin 2: L CAN Bus Pin 2 = L (Data)
Pin 3: - CAN Bus Pin 3 = - (ground, Gnd)
Pin 4: + CAN Bus Pin 4 = + (12V supply)

Instructions for the installer

3.19- INSTALLATION EXAMPLES (functional wiring and connections description)

INSTALLATION OF A BOILER WITH CONNECTION TO A DIRECT HEATING ZONE

I AF (9-10) outdoor sensor

IV $\frac{H}{2}$ (4) Collector pump

V $\frac{VF}{1}$ (1) Flow sensor heating circuit 1

I $\frac{10}{10}$ (10) Ground outdoor sensor

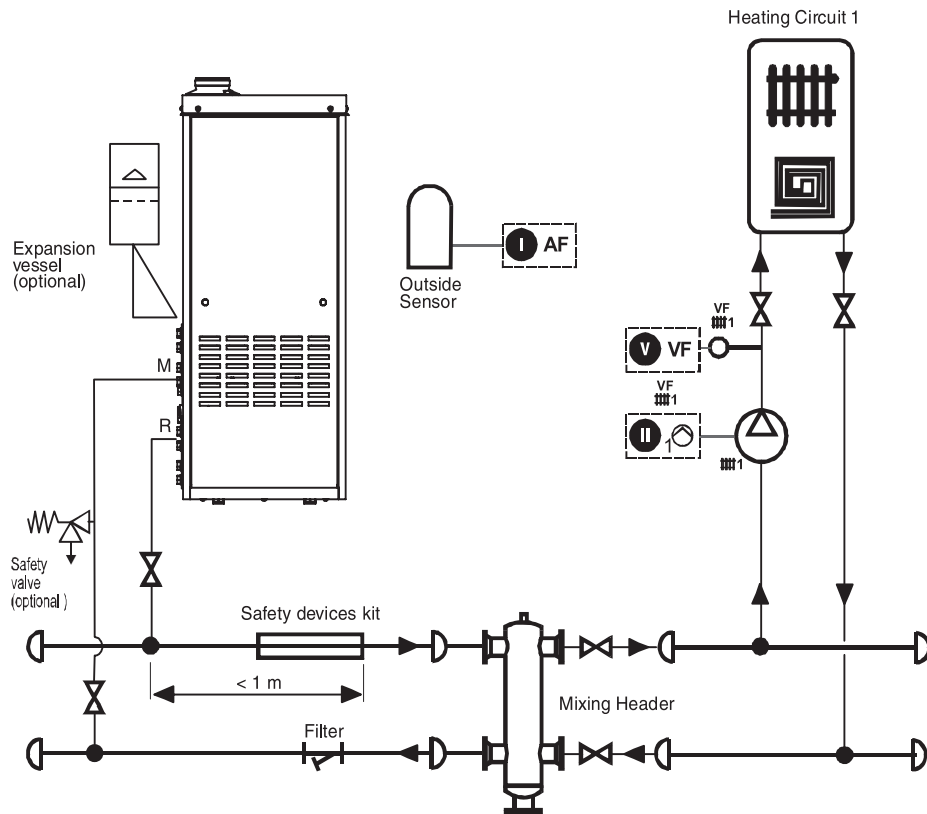









NOTE!

THE CONFIGURATIONS, SHOWN IN THIS MANUAL, ARE DOABLE BY USING THE E8 REGULATOR, SUPPLIED AS AN OPTION.

BEFORE USING OTHER MODELS OF REGULATORS, MAKE SURE THEY ARE COMPATIBLE



INSTALLATION OF A BOILER WITH CONNECTION TO TWO DIRECT HEATING ZONES + D.H.W. PRODUCTION

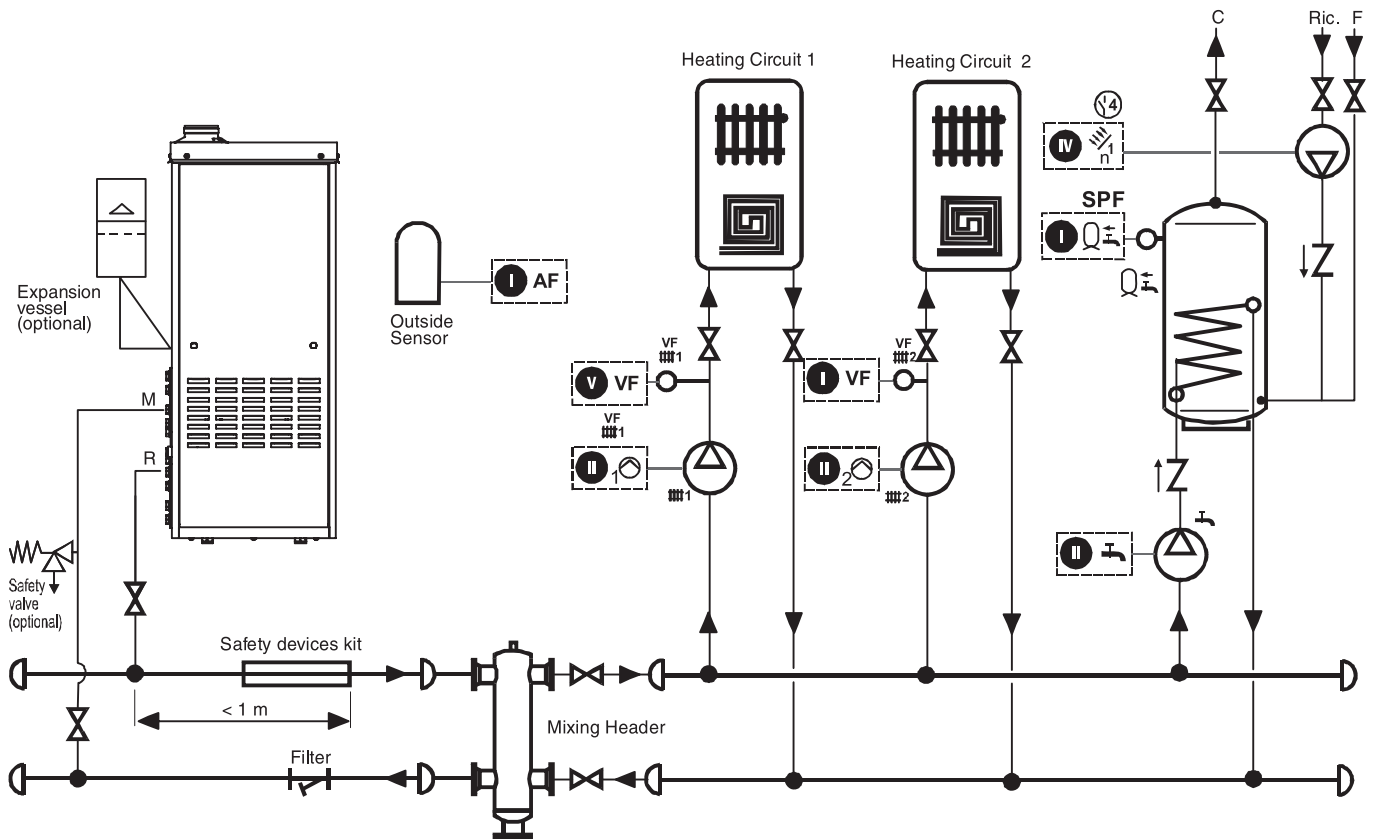

- I**  VF (4-5) Flow sensor heating circuit 2
 SPF (6-7) Storage tank sensor
AF (9-10) outdoor sensor
 - II**  #1 (4) Pump heating circuit 1
 #2 (5) Pump heating circuit 2
 (6) Cylinder charging pump
 - IV**  #1 (5) Re-circulation pump storage tank
- V**  VF #1 (1) Flow sensor heating circuit 1
 - I**  #10 (10) Ground outdoor sensor







Instructions for the installer

INSTALLATION OF A BOILER WITH CONNECTION TO ONE MIXED AND ONE DIRECT HEATING ZONES + D.H.W. PROD.

- I  (4-5) Flow sensor heating circuit 2
- SPF  (6-7) Storage tank sensor
- AF  (9-10) outdoor sensor

- V  (1) Flow sensor heating circuit 1
- I  (10) Ground outdoor sensor

- II  (4) Pump heating circuit 1
-  (5) Pump heating circuit 2
-  (6) Cylinder charging pump
-  2

- IV  (5) Re-circulation pump storage tank

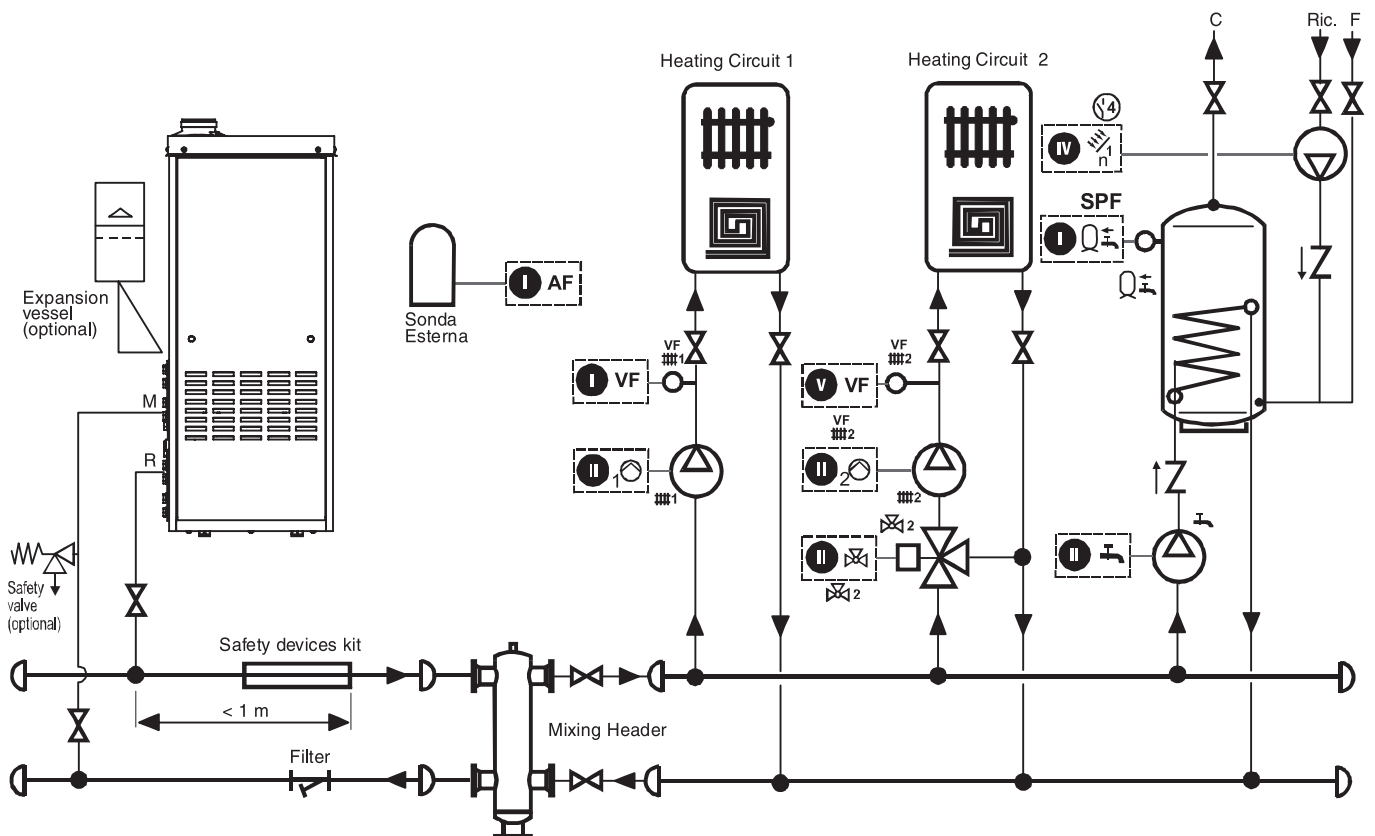

Instructions for the installer

INSTALLATION OF A BOILER WITH CONNECTION TO TWO MIXED ZONES + D.H.W. PRODUCTION

- I (4-5) Flow sensor heating circuit 2
- SPF
- (6-7) Storage tank sensor
- AF (9-10) outdoor sensor

- V (1) Flow sensor heating circuit 1
- I
- (10) Ground outdoor sensor

- II (4) Pump heating circuit 1
- (5) Pump heating circuit 2
- (6) Cylinder charging pump
- (7) Mixer motor heating circuit 2 OPEN ▲
- (8) Mixer motor heating circuit 2 CLOSE ▼
- IV (1) Mixer motor heating circuit 1 OPEN ▲
- (2) Mixer motor heating circuit 1 CLOSE ▼
- IV (5) Re-circulation pump storage tank

- V (2) Hot water tank low / Multifunction relay sensor 2

- VIII (2) PT1000 sensor solar 1 / Multifunction relay sensor 4

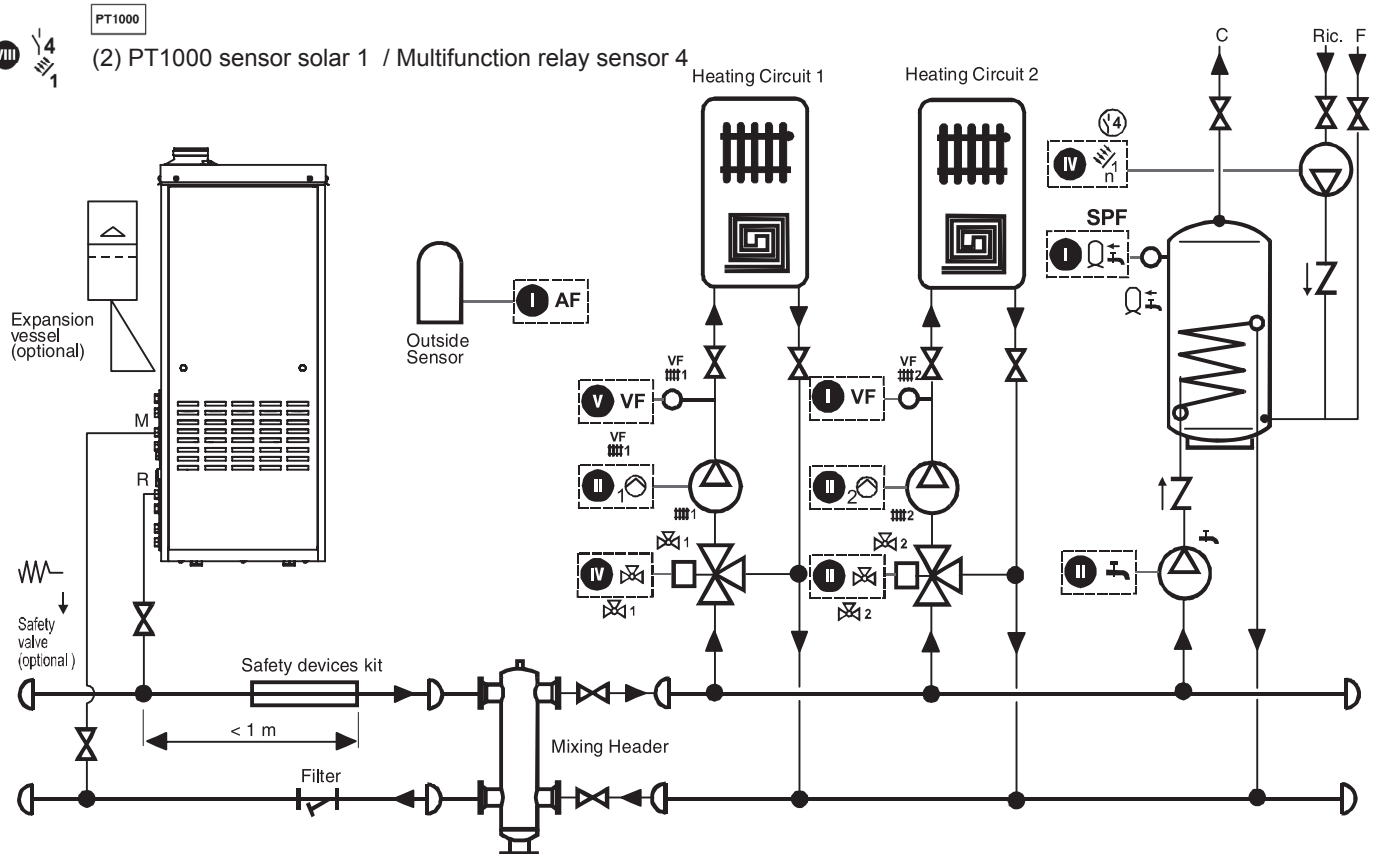

Instructions for the installer

INSTALLATION OF A BOILER WITH CONNECTION TO TWO MIXED ZONES + D.H.W. PRODUCTION BY SOLAR PANELS

- I VF (4-5) Flow sensor heating circuit 2
- SPF (6-7) Storage tank sensor
- AF (9-10) outdoor sensor

- V VF (1) Flow sensor heating circuit 1
- I 10 (10) Ground outdoor sensor

- II III1 (4) Pump heating circuit 1
- III2 (5) Pump heating circuit 2
- IV (6) Cylinder charging pump

- III2 (7) Mixer motor heating circuit 2 OPEN ▲
- III2 (8) Mixer motor heating circuit 2 CLOSE ▼

- IV III1 (1) Mixer motor heating circuit 1 OPEN ▲
- IV III1 (2) Mixer motor heating circuit 1 CLOSE ▼

- III1 (5) Re-circulation pump storage tank

- III2 (4) Collector pump

- V III2 (2) Hot water tank low / Multifunction relay sensor 2

- VIII III4 (2) PT1000 sensor solar 1 / Multifunction relay sensor 4

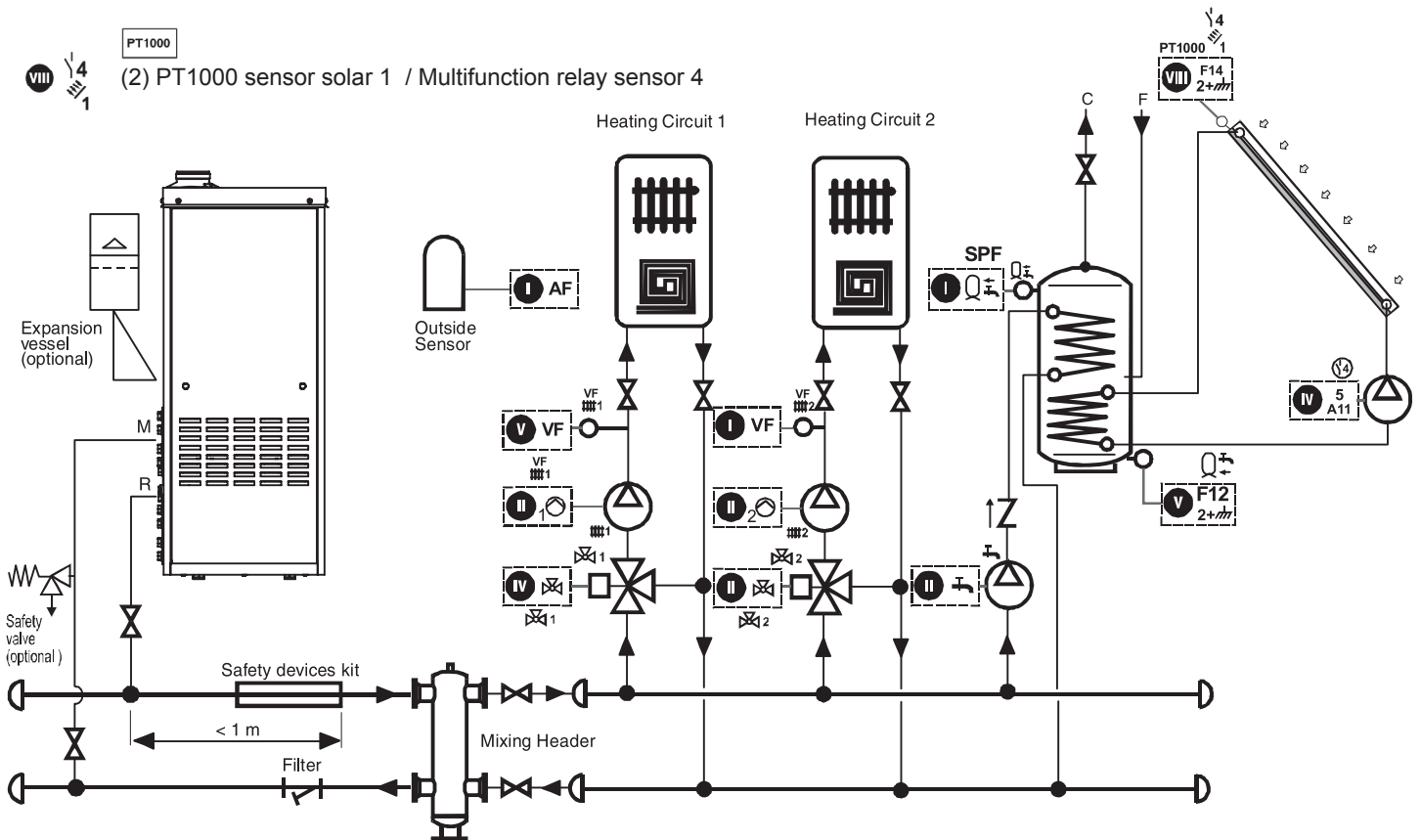

For the connection to a solar installation it is necessary to change some parameters. See Table:
Expert AREA ⇒ Level SOLAR / MF ⇒ MF 4
FUNCTION = "23"

INSTALLATION OF A BOILER WITH CONNECTION TO TWO MIXED ZONES + D.H.W. PRODUCTION

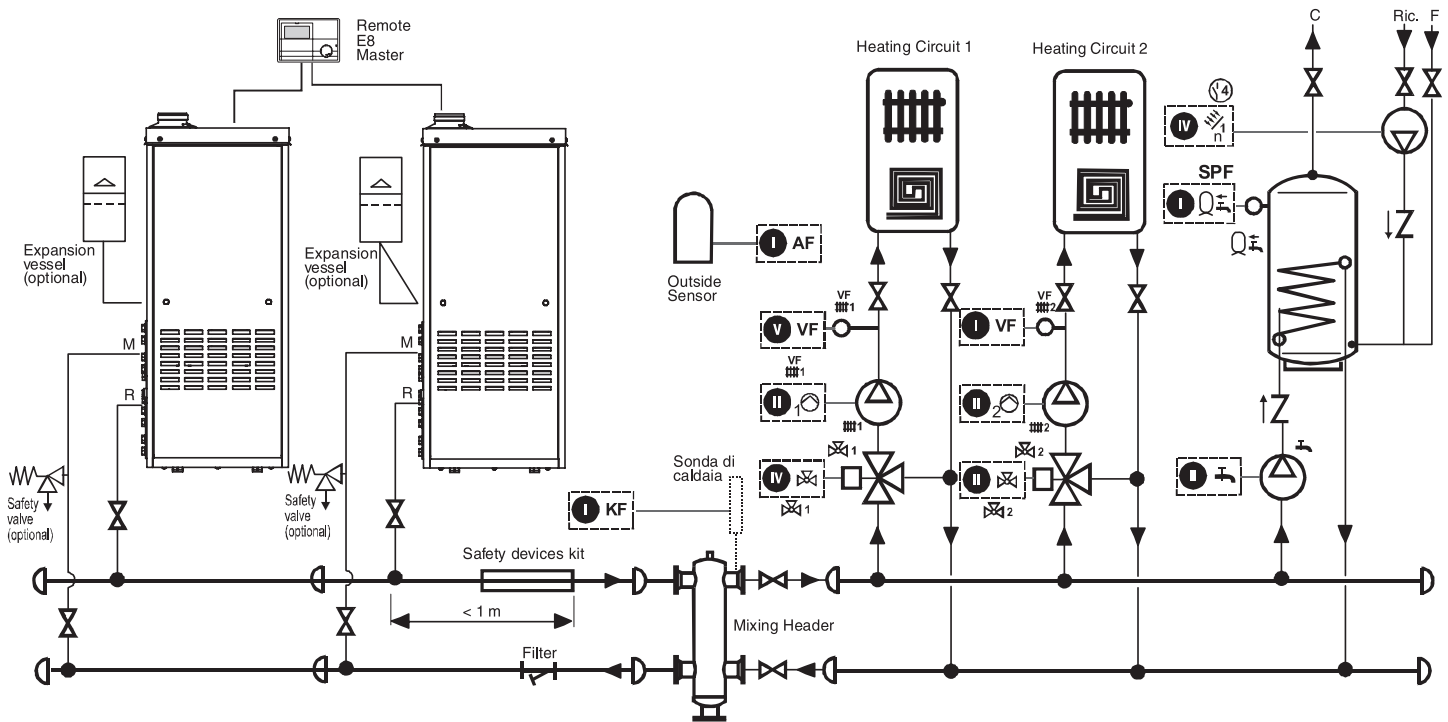

Connection of several BWA 90

The electrical connection of several BWA 90 in cascade must be done between the terminals 3-4 of Y1 (BWA 90 / 1) and 3-4 of Y1 (BWA 90 / 2) of the PCBs

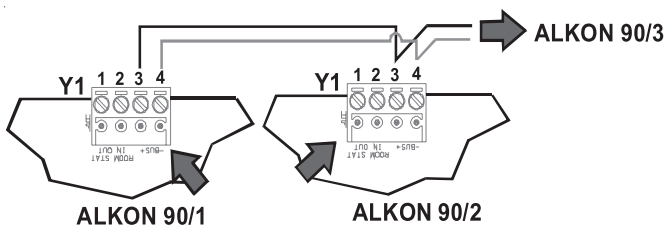

Attention!

Respect the polarity: BUS - / BUS -
BUS + / BUS +

The E8 regulator (OPTIONAL) will recognise automatically the number of boilers connected and their output .



For the connection of several BWA 90 (Max 8 boilers) it is necessary to change some parameters of prearrangement (see table Regulator E8 on page 6:
TIPE CR1 from "2" to "6"
CR1 BUS prearranged to "03"

Connections on to the MASTER controller

The connections of the secondary circuit have to be done on to the MASTER controller.

- VF (4-5) Flow sensor heating circuit 2
- SPF (6-7) Storage tank sensor
- AF (9-10) outdoor sensor
- ##1 (4) Pump heating circuit 1
- ##2 (5) Pump heating circuit 2
- F (6) Cylinder charging pump
- ##2 (7) Mixer motor heating circuit 2 OPEN
- ##2 (8) Mixer motor heating circuit 2 CLOSE
- ##1 (1) Mixer motor heating circuit 1 OPEN
- ##1 (2) Mixer motor heating circuit 1 CLOSE
- ##1 (5) Re-circulation pump storage tank
- ##2 (4) Collector pump

- | | |
|--------|-----------------------------------|
| VF ##1 | (1) Flow sensor heating circuit 1 |
| I ##10 | (10) Ground outdoor sensor |

Instructions for the installer

3.20 - EXAMPLES OF CONNECTION WITH OPTIONAL KITS

INSTALLATION OF A SINGLE ALKON 90

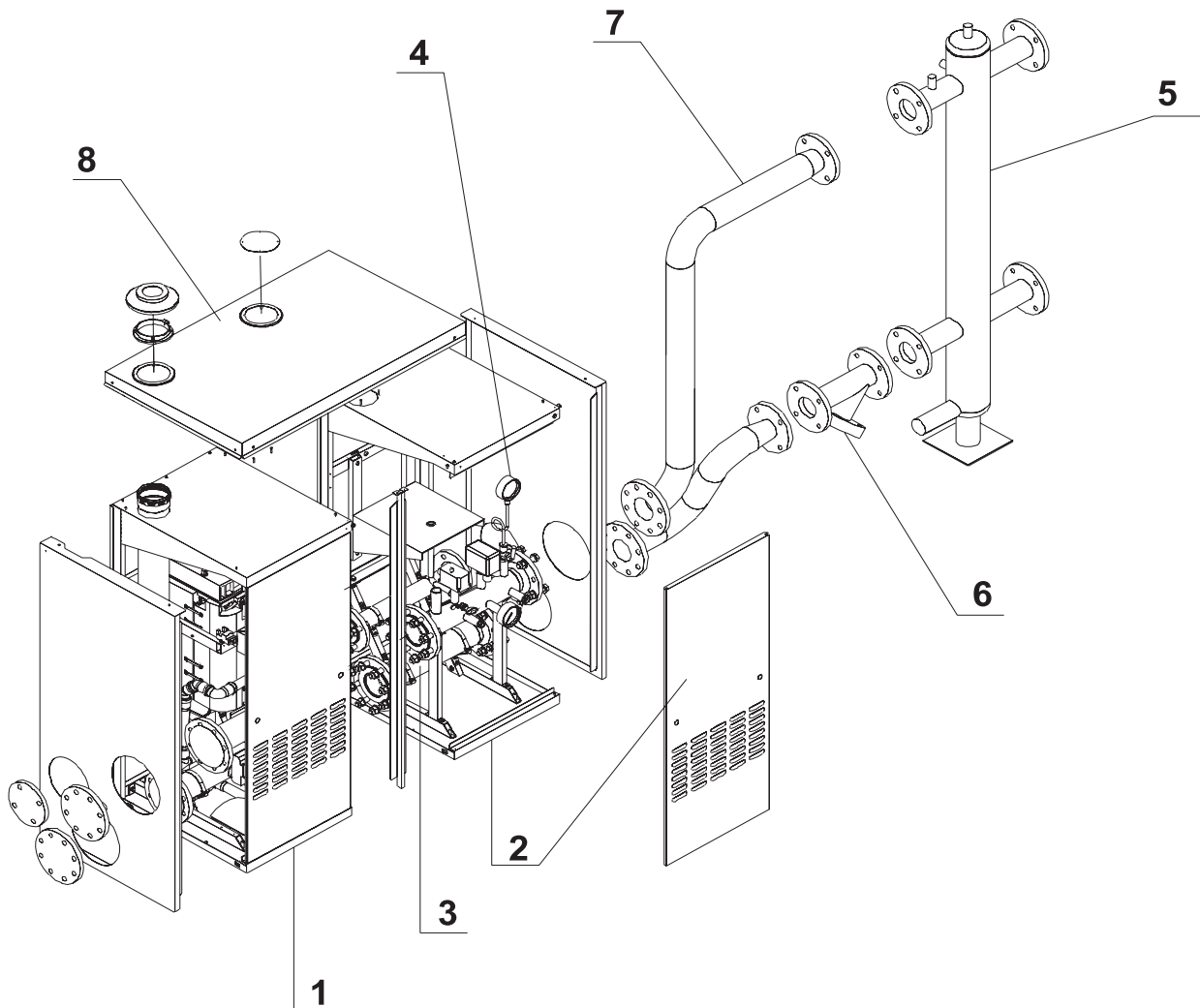

- 1 - 41010336 = BWA 90 Master (NG)
with side panels and flanges
- 41010337 = BWA 90 Master (LPG)
with side panels and flanges
- 2 - 00361529 = External frame for safety devices kit
- 3 - 00361528 = Additional safety kit and manifold
- 4 - 00361316 = Additional protection and control kit
- 5 - 00361499 = Hydraulic header kit up to 90-180 kW
DN65
- 6 - 00361488 = Y filter kit DN 65
- 7 - 00361484 = Hydraulic header connection kit DN 65
- 8 - 00361522 = Outdoor cover kit for 2 boilers

- 00262514 = Elbow 90° Ø 100
- 00262476 = Elbow 45° Ø 100



Note:

The insulation of the battery flow and return manifolds is suggested.

SMOKE ACCESSORIES

- 00361493 = Vertical flue terminal Ø 100
- 00361494 = Horizontal flue terminal Ø 100
- 00361495 = Extension Ø 100 L = 1000

REGULATION ACCESSORIES

- 00361332 = E8 regulator kit
- 00361359 = Box for E8 regulator kit
- 00361358 = BM8 remote control kit
- 00361602 = BCM panel kit

INSTALLATION OF TWO BWA 90 IN BATTERY

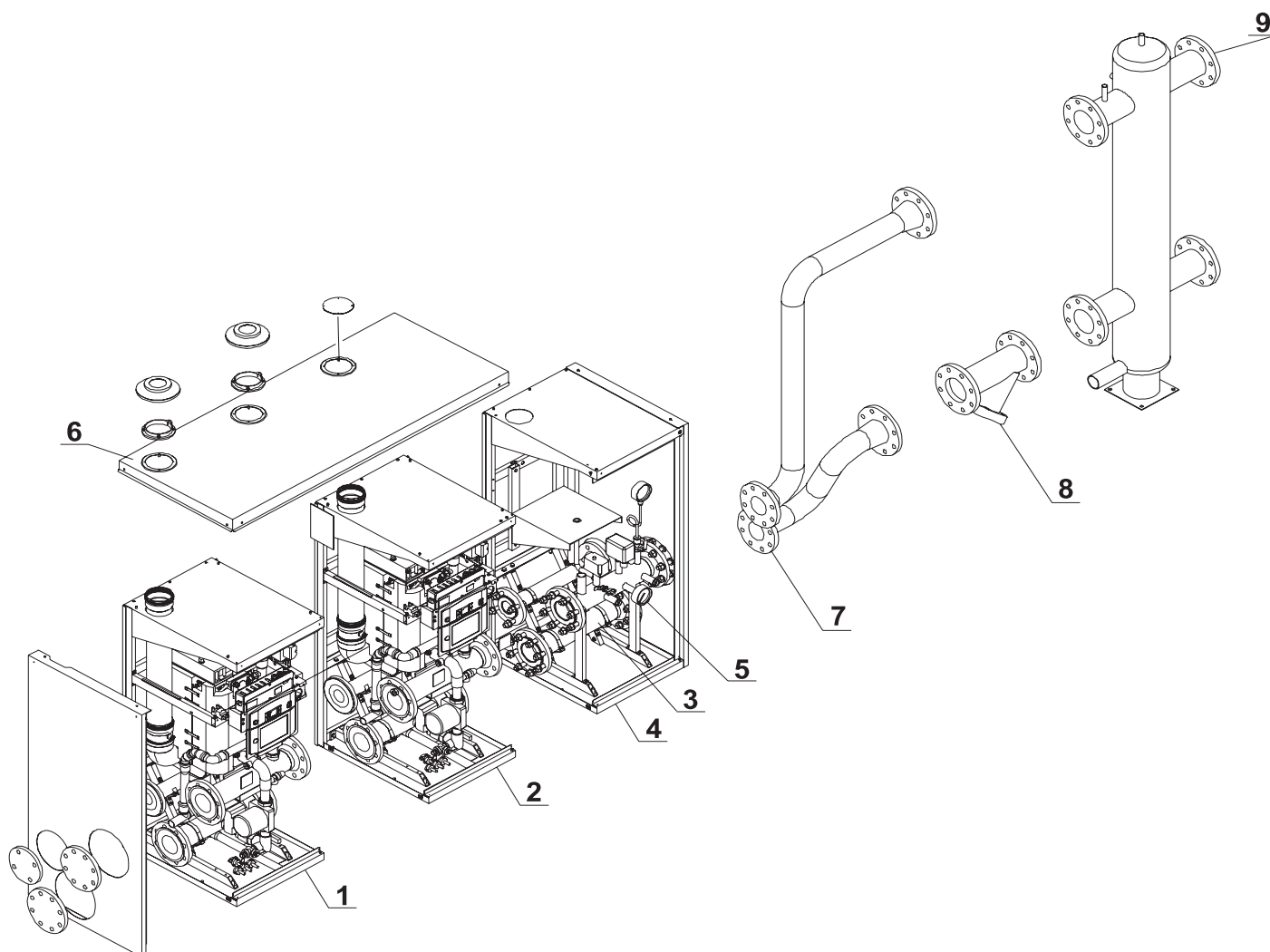

- 1 - 41010336 = BWA 90 Master (NG)
with side panels and flanges
- 41010337 = BWA 90 Master (LPG)
with side panels and flanges
- 2 - 41010456 = BWA 90 (NG)
- 41010458 = BWA 90 (LPG)
- 3 - 00361528 = External frame for safety devices kit
- 4 - 00361529 = Additional safety kit and manifold
- 5 - 00361316 = Additional protection and control kit
- 6 - 00361523 = Outdoor cover kit for 3 modules
- 7 - 00361484 = Hydraulic header connection kit DN 65
- 8 - 00361488 = Y filter kit DN 65
- 9 - 00361499 = Hydraulic header kit up to 90-180 kW
DN 65



Note:

The insulation of the battery flow and return manifolds is suggested.

REGULATION ACCESSORIES

- 00361332 = E8 regulator kit
- 00361359 = Box for E8 regulator kit
- 00361358 = BM8 remote control kit
- 00361602 = BCM panel kit

SMOKE ACCESSORIES

- 00361493 = Vertical flue terminal Ø 100
- 00361494 = Horizontal flue terminal Ø 100
- 00361495 = Extension Ø 100 L = 1000
- 00262514 = Elbow 90° Ø 100
- 00262476 = Elbow 45° Ø 100

Instructions for the installer

INSTALLATION OF THREE BWA 90 IN BATTERY

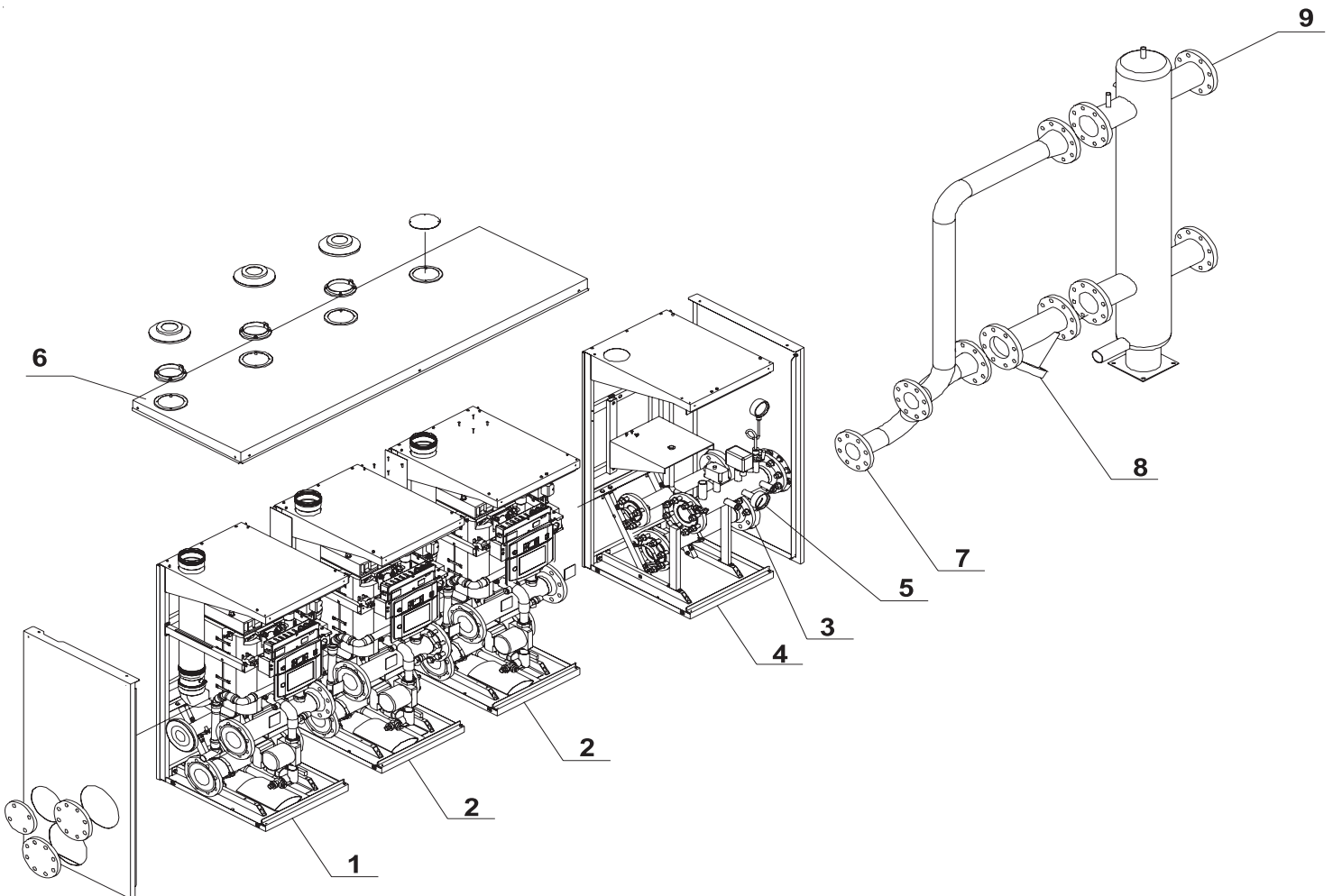

- 1 - 41010336 = BWA 90 Master (NG)
with side panels and flanges
- 41010337 = BWA 90 Master (LPG)
with side panels and flanges
- 2 - 41010456 = BWA 90 (NG)
- 41010458 = BWA 90 (LPG)
- 3 - 00361528 = External frame for safety devices kit
- 4 - 00361529 = Additional safety kit and manifold
- 5 - 00361316 = Additional protection and control kit
- 6 - 00361524 = Outdoor cover kit for 4 modules
- 7 - 00361487 = Hydraulic header connection kit DN 100
- 8 - 00361489 = Y filter kit Y DN100
- 9 - 00361500 = Hydraulic header kit up to 180-450 kW
Dn100

SMOKE ACCESSORIES

- 00361493 = Vertical flue terminal Ø 100
- 00361494 = Horizontal flue terminal Ø 100
- 00361495 = Extension Ø 100 L = 1000
- 00262514 = Elbow 90° Ø 100
- 00262476 = Elbow 45° Ø 100



Note:

The insulation of the battery flow and return manifolds is suggested.

REGULATION ACCESSORIES

- 00361332 = E8 regulator kit
- 00361359 = Box for E8 regulator kit
- 00361358 = BM8 remote control kit
- 00361602 = BCM panel kit

INSTALLATION OF FOUR BWA 90 IN BATTERY

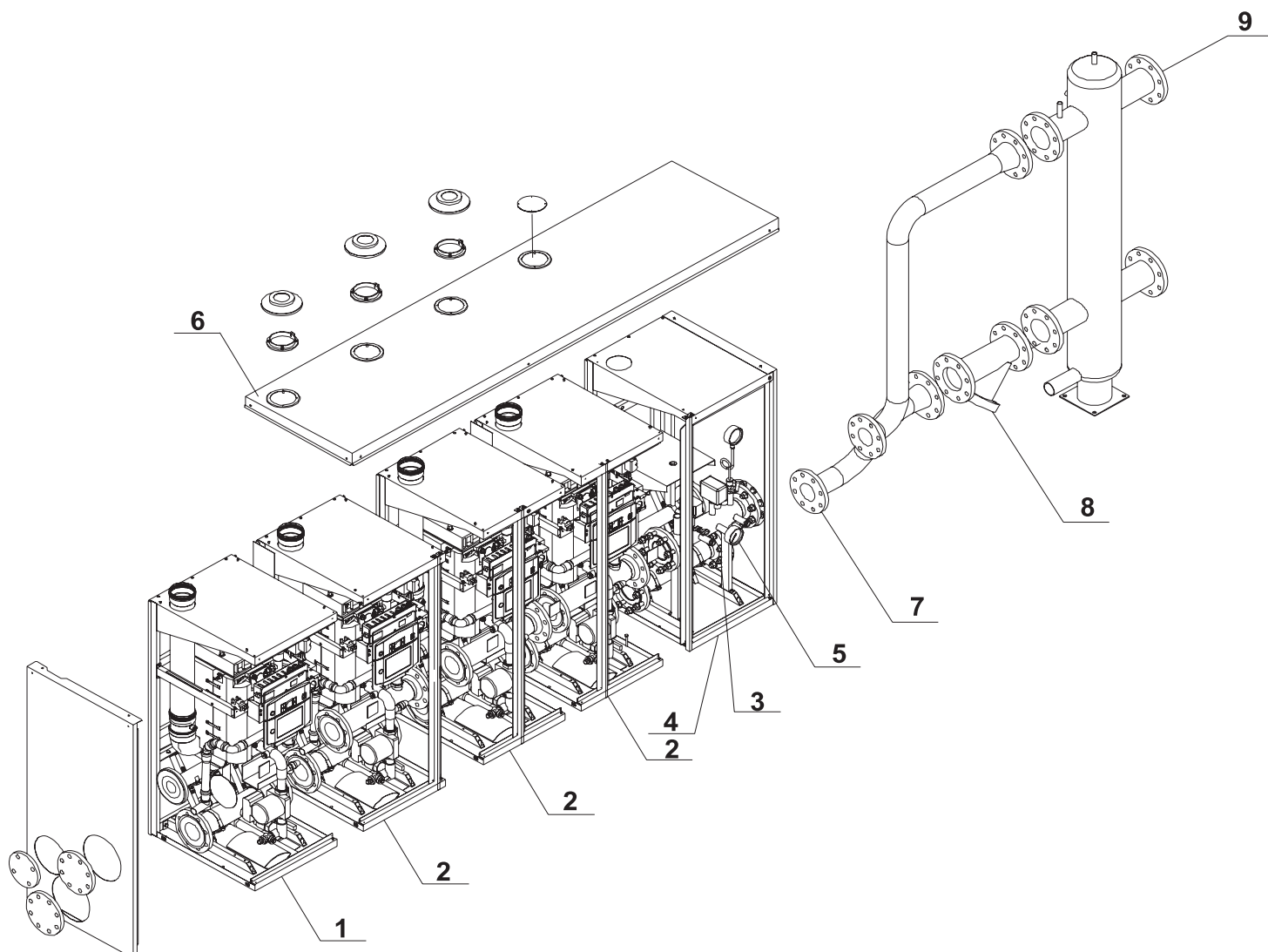

- 1 - 41010336 = BWA 90 Master (NG)
with side panels and flanges
- 41010337 = BWA 90 Master (LPG)
with side panels and flanges
- 2 - 41010456 = BWA 90 (NG)
- 41010458 = BWA 90 (LPG)
- 3 - 00361528 = External frame for safety devices kit
- 4 - 00361529 = Additional safety kit and manifold
- 5 - 00361316 = Additional protection and control kit
- 6 - 00361525 = Outdoor cover kit for 4 modules + 1
- 7 - 00361487 = Hydraulic header connection DN 100
- 8 - 00361489 = Kit filter kit Y DN100
- 9 - 00361500 = Hydraulic header kit up to 180-450 kW
Dn100

SMOKE ACCESSORIES

- 00361493 = Vertical flue terminal Ø 100
- 00361494 = Horizontal flue terminal Ø 100
- 00361495 = Extension Ø 100 L = 1000
- 00262514 = Elbow 90° Ø 100
- 00262476 = Elbow 45° Ø 100



Note:

The insulation of the battery flow and return manifolds is suggested.

REGULATION ACCESSORIES

- 00361332 = E8 regulator kit
- 00361359 = Box for E8 regulator kit
- 00361358 = BM8 remote control kit
- 00361602 = BCM panel kit

Instructions for the installer

3.21 - FILLING THE SYSTEM



Warning!

Do not mix the CH system's water with anti-freeze or anti-corrosion solutions using wrong concentrations! It could cause damage to the washers and could provoke noise during normal boiler operation.

The Manufacturer refuses all liability for injury to persons, animals or damage to property deriving from not having respected the above mentioned recommendations.

the installation could accumulate in the boiler, compromising its operation.. For that reason the installation must be equipped with own drain cock, correctly sized according to the installation water content.

Once all the connections are made, it is possible to fill the circuit.

For the filling of the system it is necessary to fit a filling valve on the C.H. return.

The boiler is equipped with its own drain cock, whose position is shown in the figure of page 11. This cock **never** has to be used for the drain of the system, because all the dirtiness of

EXAMPLE OF FILLING-UP SYSTEM MANIFOLD

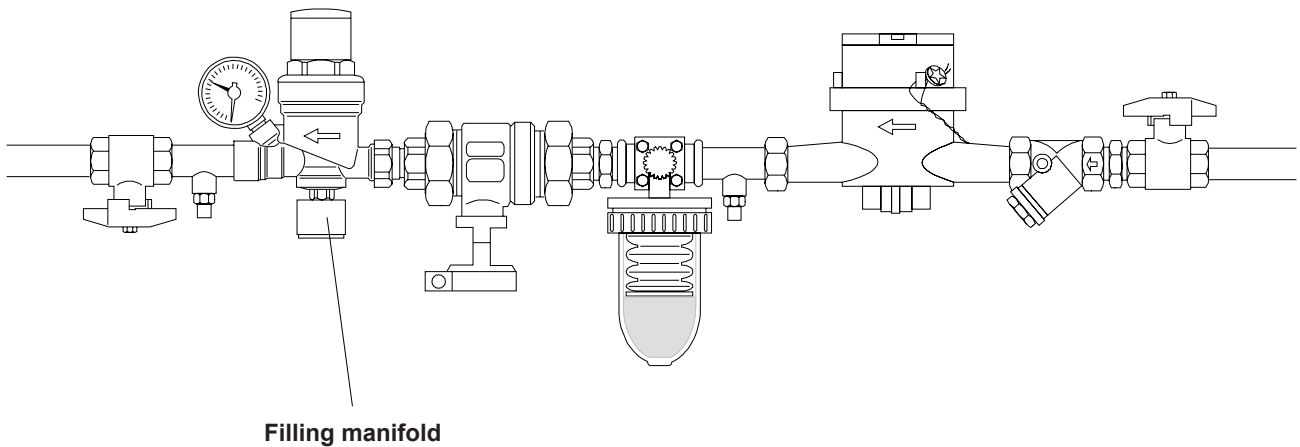

3.22 - INITIAL LIGHTING

PRELIMINARY CHECKS



The first ignition must be carried out by a qualified technician. Failure to do so could cause injury to persons, animals or damage to property. The Manufacturer shall not be held liable for any injury and/or damage.

Before lighting the boiler check that:

- the boiler installation has been carried out in accordance with the specific Standards and regulations in force for the gas part and for the electrical part;
- the air supply and the discharge of the products of combustion are carried out in the correct way in accordance to the specific Standards and regulations in force;
- the gas supply system is correctly dimensioned for the boiler's output and is fitted with all the safety and control devices prescribed by the regulations in force;
- the electrical supply must be 230 V - 50 Hz;
- the system has been filled with water (pressure registered on the gauge 0,8/1 bar with pump not running);
- any on-off valves of the system are open;
- the mains supply gas corresponds to the one which the boiler has been calibrated for: otherwise convert the boiler to use the available gas (refer to section: "GAS CONVERSION"); this operation must be carried out by a qualified technician in compliance to the regulations in force;
- the gas supply cock is open;
- there are no gas leaks;
- the external mains supply switch is on;
- the system's safety valve on the boiler is not blocked and that it is connected to the sewage system;
- the condensate drain siphon has been filled with water;



DANGER!

Before firing the appliance fill up the siphon through the filling hole and check the correct drainage of the condensate.

If the appliance is used with the condensate drain siphon empty this could lead to danger of

- there are no water leaks;
- all the necessary ventilation conditions and minimum clearance distances are guaranteed for subsequent servicing.

LIGHTING AND SHUTTING DOWN PROCEDURES

For lighting and shutting down the boiler refer to the "INSTRUCTIONS GUIDE FOR THE PERSON IN CHARGE OF THE APPLIANCE"

Information to be passed on to the person in charge of the appliance

The person in charge of the appliance must be instructed on the use and operation of the boiler and in particular detail:

- Hand the booklet: "INSTRUCTIONS GUIDE FOR THE PERSON IN CHARGE OF THE APPLIANCE", as well as all the other literature relative to the appliance, and placed in the envelope contained in the packaging, to the person in charge of the appliance. **The person in charge of the appliance must retain this literature for any future reference.**
- Inform the person in charge of the appliance of the importance of the air vents and of the flue outlet system, stressing the fact that absolutely no modification can be made.
- Inform the person in charge of the appliance regarding the control of the system water pressure and how to restore it to the correct value.
- Explain and demonstrate to the person in charge of the appliance the correct function and adjustment of the temperature, thermostats and radiators for the economic use of the system.
- Remind the person in charge of the appliance that a comprehensive service and the measurement of the combustion efficiency should be carried out regularly (as requested by the national law).
- If the appliance is sold or transferred to another owner or if the present user moves home and leaves the appliance installed, ensure yourself that the manual always follows the appliance so that it can be consulted by the new owner and/or installer.

Instructions for the installer

3.23 - BURNER ADJUSTMENT



WARNING!

All the instructions indicated below are for the exclusive use of qualified service technicians or installers.



All the boilers are supplied already calibrated and tested. If it is necessary to change the calibration due to gas conversion or adaptation to the mains supply system, the gas valve must be re-calibrated.

Warning: during this operation do not request any DHW draw-off .

1) Max output adjustment

- Connect a suitable CO₂ gas analyser to the sampling point in the flue inlet/outlet terminal.
- Pressing simultaneously the keys + (increase) and – (decrease) for at least 3 seconds the boiler will operate in the CH mode at the maximum output

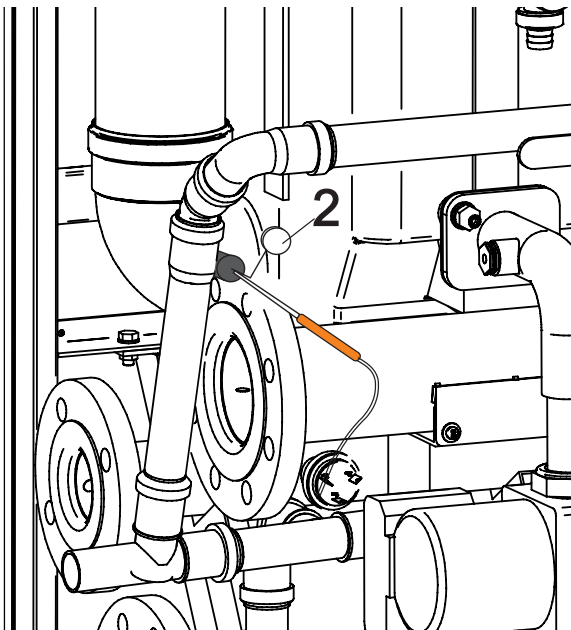

(led 1 illuminated).

- Check that the CO₂ values are within the values indicated in the table "Burner pressures"
- If necessary correct the value by turning the adjustment

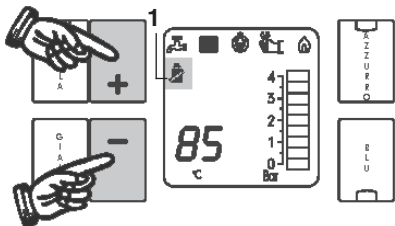

screw "A" in a CLOCKWISE direction to decrease the value and in an ANTICLOCKWISE direction in order to increase it.

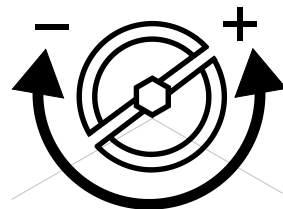
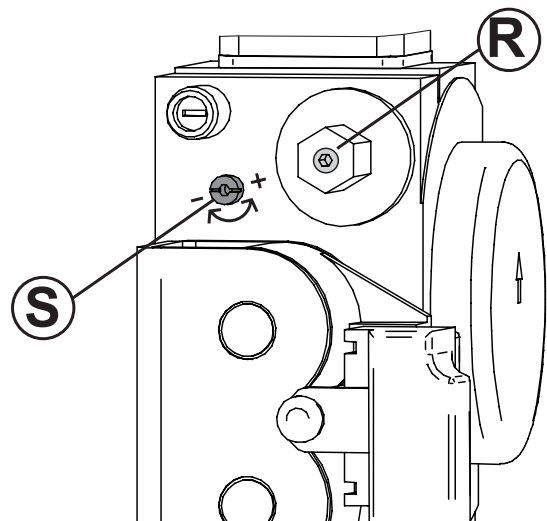

S
MAXIMUM OUTPUT
ADJUSTMENT SCREW

S) Min output adjustment

- By pressing the key "- decrease" again the boiler will operate at the minimum output (led 1 blinking).

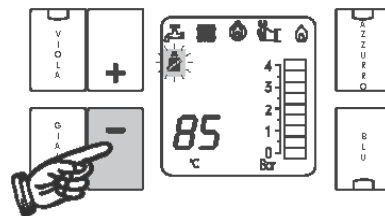

- To disenable the **CHIMNEY SWEEPER MODE** press the keys + (increase) and – (decrease) simultaneously (led 1 off).

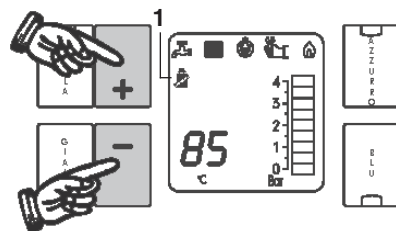

- Check that the CO₂ values are within the values indicated in the table "Burner pressures"

Instructions for the installer

- If necessary correct the value by turning the adjustment screw "B" in a CLOCKWISE direction to increase the value and in an ANTICLOCKWISE direction in order to decrease it.

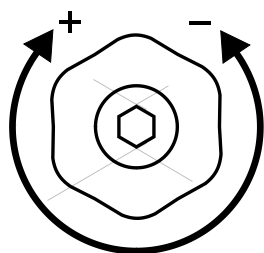
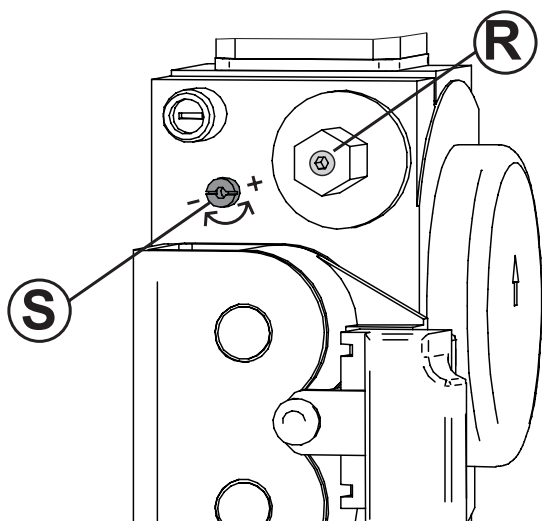

R
MINIMUM OUTPUT
ADJUSTMENT
SCREW

C) COMPLETION OF THE BASIC ADJUSTMENTS

- Check the CO₂ values at the minimum and maximum outlet
- If necessary make the required adjustments



To ensure correct operation the CO₂ values have to be adjusted with extreme care respecting the values indicated in the table.

- Close the sampling test point in the flue inlet/outlet terminal with the appropriate cap C.

In case of replacement of the gas valve or ignition difficulty:

Tighten the maximum adjustment screw "A" in a clockwise direction until you arrive to the abutting end, than slacken for 3 turns. Verify the boiler ignition; if the boiler goes into lockout slacken the screw "A" again of one turn, than retry the ignition. If the boiler goes into lockout again, carry out the above indicated operations until the boiler is lighted. At this point carry out the burner adjustment as previously indicated.

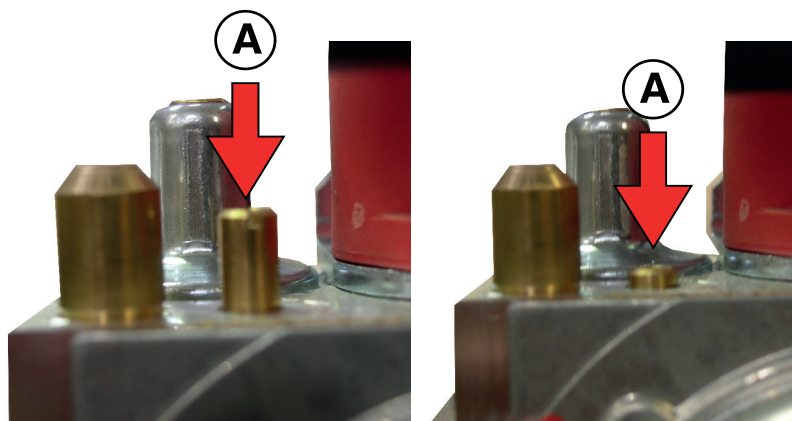

INJECTORS – PRESSURES

Check the CO₂ levels often, especially at low flow rate

BWA 90									
Gas Type	Supply pressure	Ø Injectors	Diaphragm	Fan Speed			CO ₂ levels		Starting power
	[mbar]	(mm)	[mm]	min	max		[%]		[%]
				FL [%FU]	FH [%FU]	FU[x10 Hz]	min	max	IG
Gas nat. (G20)	20	9	-	26	90	10	8,8	9,1	45
Gas nat. (G25)	25	9	-	26	90	11	8,8	8,8	45
Propan (G31)	37	7	-	26	81	11	10,5	10,9	35

Instructions for the installer

3.24 - PROGRAMMING OF THE OPERATING PARAMETERS

WARNING! THESE OPERATIONS ARE ACCESSIBLE TO TRAINED INSTALLERS AND SERVICE ENGINEERS ONLY FOR CHANGING THE PARAMETER SETTINGS

Press the **YELLOW** key and the **LIGHT BLUE** key simultaneously to enter in the service mode **SE** and change the values of the pre-set operating parameters.

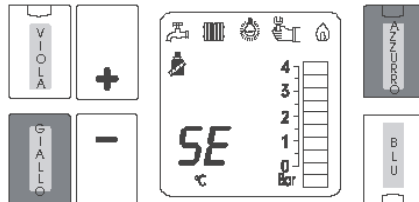

(Operation C)

After setting the desired value pressing the **YELLOW** key stores this new value in the memory.

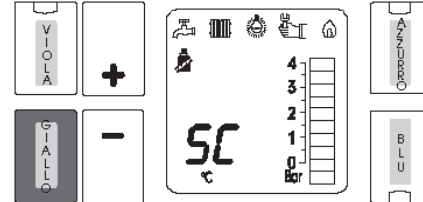

eBUS IDENTIFICATION CODE

By pressing the **YELLOW** key you have access to the first adjustable parameter **eBUS IDENTIFICATION CODE (SC)**.

Standard setting 0

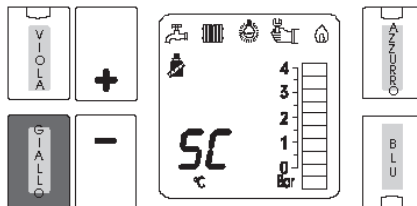

(Operation A)

By pressing the **YELLOW** key again the standard parameter setting is displayed.

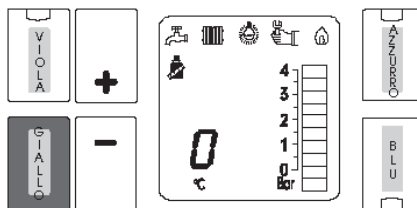

(Operation B)

By pressing the keys + (increase) or – (decrease) a number of times the parameter can be changed.

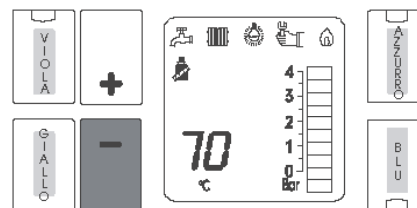

BURNER MODULATION LEVEL IN IGNITION

Continue to change the parameters by pressing the – key (decrease).

The successive parameter which can be changed is: **BURNER MODULATION LEVEL IN IGNITION (IG)**

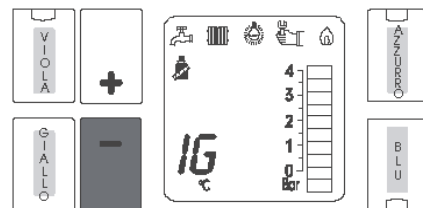

Repeat the operations A-B-C for setting the desired value from 0 to 99%.

Standard Natural Gas setting 45%

Standard LPG setting 35%

PUMP OVERRUN

Continue to change to the parameters by pressing the – key (decrease).

The successive parameter which can be changed is: **PUMP OVERRUN (Po)**.

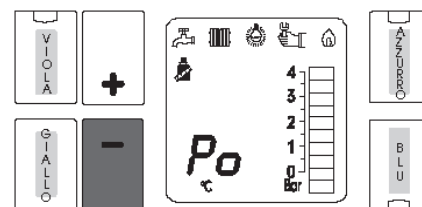

Repeat the operations A-B-C for setting the desired value from 1 to 10 minutes.

Standard setting: 5 minutes



WARNING!
DO NOT CHANGE THE PARAMETER

MODULATING PUMP MODULATING CAPACITY

Continue to change the parameters by pressing the – key (decrease).

The successive parameter which can be changed is: **MODULATING PUMP MODULATING CAPACITY (Pr)**.

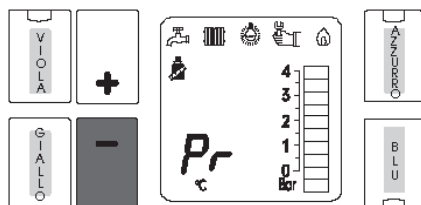

Repeat the operations A-B-C for setting the desired value from 20 to 99%.

Standard setting: 99%

MODULATING PUMP MINIMUM MODULATION LEVEL

Continue to change to the parameters by pressing the – key (decrease).

The successive parameter which can be changed is: **MODULATING PUMP MINIMUM MODULATION LEVEL (PL)**.

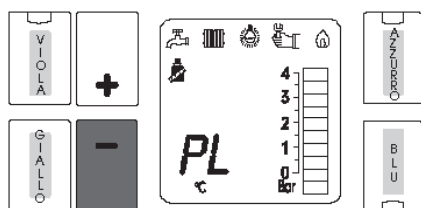

Repeat the operations A-B-C for setting the desired value from 0 to 99%.

Standard setting: 16%

SETTING OF THE MINIMUM HEATING TEMPERATURE

Continue to change to the parameters by pressing the – key (decrease).

The successive parameter which can be changed is: **SETTING OF THE MINIMUM HEATING TEMPERATURE (HL)**.

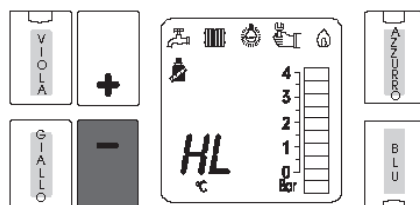

Repeat the operations A-B-C for setting the desired value from 20 to 60°C.

Standard setting: 35°C

SETTING OF THE MAXIMUM HEATING TEMPERATURE

Continue to change to the parameters by pressing the – key (decrease).

The successive parameter which can be changed is: **SETTING OF THE MAXIMUM HEATING TEMPERATURE (HH)**.

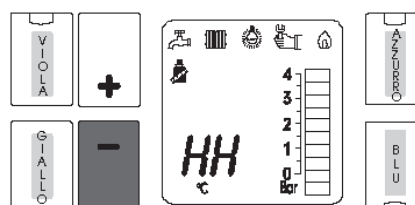

Repeat the operations A-B-C for setting the desired value from 65 to 85°C.

Standard setting: 80°C

SETTING OF THE MINIMUM DHW TEMPERATURE (only if combined with an external storage tank)

Continue to change to the parameters by pressing the – key (decrease).

The successive parameter which can be changed is: **SETTING OF THE MINIMUM DHW TEMPERATURE (dL)**.

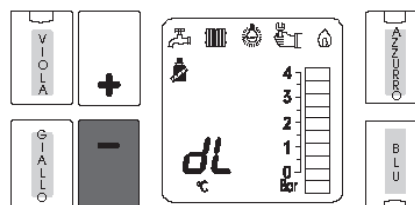

Repeat the operations A-B-C for setting the desired value from 35 to 45°C.

Standard setting: 40°C

SETTING OF THE MAXIMUM DHW TEMPERATURE (only if combined with an external storage tank)

Continue to change to the parameters by pressing the – key (decrease).

The successive parameter which can be changed is: **SETTING OF THE MAXIMUM DHW TEMPERATURE (dH)**.

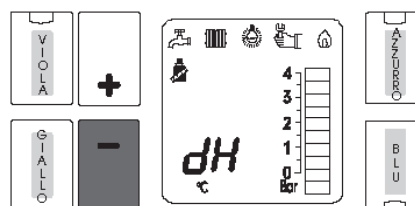

Repeat the operations A-B-C for setting the desired value from 50 to 65°C.

Standard setting: 60°C.

4

SERVICING SCHEDULE



To ensure the continued safe and efficient operation of the boiler it is highly recommended that it is checked at regular intervals and serviced when necessary, and that only original spare parts are used. The law in force states that the boiler must be serviced annually.



If the boiler is not checked and serviced when necessary it could cause material and personal damages.

For this reason The Manufacturer recommends that a servicing contract should be made with a heating installer.

The boiler must have regular maintenance and cleaning in order to ensure reliable and efficient operation. Regular attention will prolong the life of the boiler.

The frequency of servicing will be determined by the service engineer and will depend on appliance's state of condition.

INSTRUCTIONS FOR SERVICING



To ensure a long life to all your boiler components and in order not to alter the conditions of the approved product only original spare parts must be used.

Before servicing always carry out the following steps:

- Disconnect the mains electricity supply.
- Separate the appliance from the electrical supply by means of a separating device with an opening contact of at least 3 mm (for example safety devices or power switches) and ensure yourself that it cannot be accidentally reinserted.
- Close the on-off valve fitted upstream of the boiler.
- If necessary, and in function of the type of work to be carried out, close any on-off valves fitted on the CH flow and return pipes, as well as the cold inlet valve.
- Remove the appliance's front panel.

After having carried out all the necessary maintenance always follow these steps:

- Open the CH flow and return valves as well as the cold inlet valve (if previously closed),
- Purge and, if necessary, proceed with restoring the heating system's pressure until a pressure of 0,8/1 bar is reached.
- Open the on-off gas valve.
- Reconnect the appliance to the electrical supply and switch on the mains electrical supply.
- Test for gas soundness, on the gas side and on the water side.
- Replace the appliance's front panel.



IMPORTANT:

After having serviced the appliance, remember to reset the counter to zero by selecting the text "Cr" from the parameter menu and entering the relative unblocking code.

TABLE OF THE RESISTANCE VALUES IN FUNCTION OF THE HEATING SENSOR (SR) AND RETURN HEATING SENSOR TEMPERATURE (SRR)

T°C	0	1	2	3	4	5	6	7	8	9
0	32755	31137	29607	28161	26795	25502	24278	23121	22025	20987
10	20003	19072	18189	17351	16557	15803	15088	14410	13765	13153
20	12571	12019	11493	10994	10519	10067	9636	9227	8837	8466
30	8112	7775	7454	7147	6855	6577	6311	6057	5815	5584
40	5363	5152	4951	4758	4574	4398	4230	4069	3915	3768
50	3627	3491	3362	3238	3119	3006	2897	2792	2692	2596
60	2504	2415	2330	2249	2171	2096	2023	1954	1888	1824
70	1762	1703	1646	1592	1539	1488	1440	1393	1348	1304
80	1263	1222	1183	1146	1110	1075	1042	1010	979	949
90	920	892	865	839	814	790	766	744	722	701

Relation between the temperature (°C) and the nom. resistance (Ohm) of the heating sensor SR and the return heating sensor SRR.

Example: At 25°C, the nominal resistance is 10067 Ohm
At 90°C, the nominal resistance is 920 Ohm

CLEANING THE CONDENSATE DRAIN SIPHON

In order to check and clean the siphon carry out the following steps:

- disconnect the transparent pipe (A) check that no deposits have accumulated inside the siphon. If there are any deposits flush them out with clean water;
- reassemble the siphon in reverse order.



Danger!

Before commissioning the appliance fill the siphon via the filling hole and check the correct drainage of the condensate.

If the appliance is used with the condensate drain siphon empty this could lead to danger of intoxication following the escape of flue gasses.

Condensate coming from the boiler
Condensate drain.
Pipe to be connected to the sewage

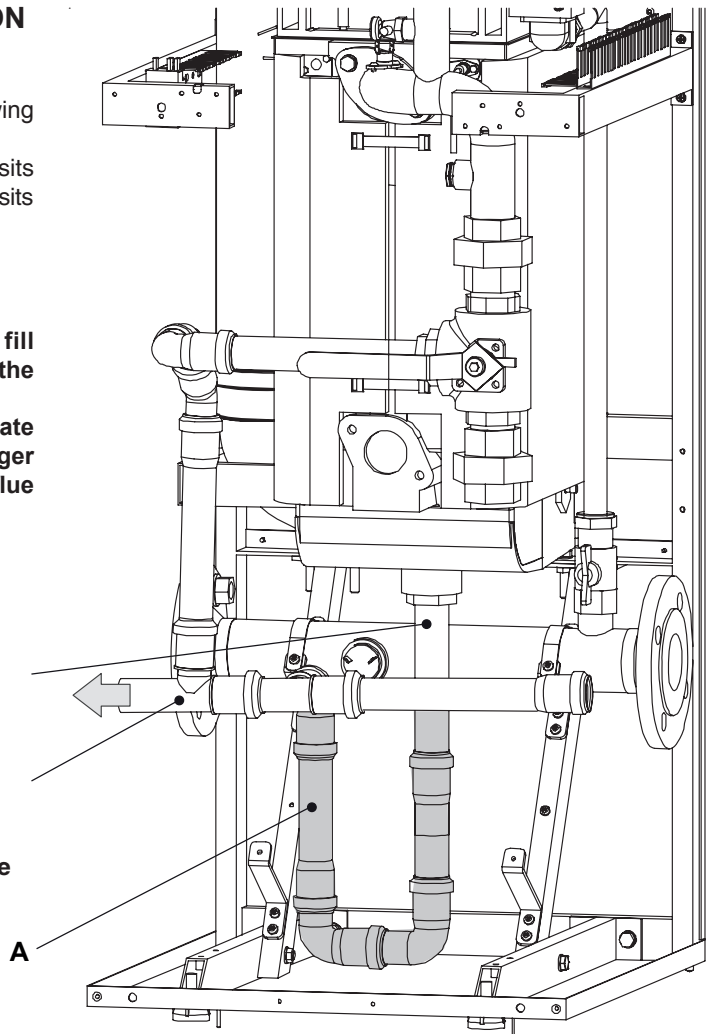

Guarnizione di tenuta fra distributore e corpo scambiatore



DANGER!

It is absolutely necessary to replace the gasket at any time the inspection or maintenance is made on the burner.

When refitting the mixer tighten the nuts progressively and in crossed way, by using a dynamometric wrench adjusted at 10 Nm (1 kgm).

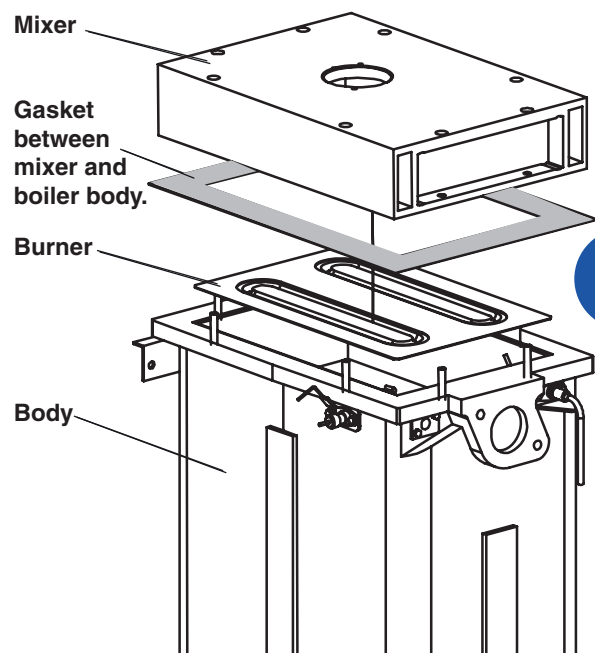

■ Servicing schedule

Service operations suggested	Check once a year	Check every two years
Control of the water soundness components	●	
Inspect for the gas circuit soundness	●	
Check the good operation of water and gas safety devices	●	
Clean the combustion circuit	●	
Clean the burner and check the ignition	●	
Clean the fan	●	
Control the operation of the fan		●
Check the gas flow rate and ad just if necessary	●	
Inspect the smoke evacuation duct	●	
Check the idraulic connection		●
Make the combustion analysis		●
Check the good operation of the electrical and electronic components		●
Clean the condensate siphon and check its good draining	●	

5

FAULT FINDING

5.1 - ERROR CODES

The boiler is fitted with an integrated diagnostic readout which, in case of malfunction, consents the immediate individuation of the type of fault directly on the control panel display

In the following fault finding table our purpose is to give some technical information regarding the solutions to any problems which could occur during boiler operation or commissioning of the boiler.

When the fault signalling led (1) is on, press the LIGHT BLUE key (2) to check the error code on the display (3).

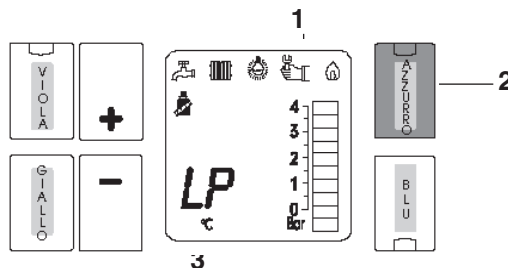

Code: Description: DHW sensor failure (only if the boiler is combined with an external storage tank)

db

Corrective action: Check the sensor's efficiency and/or its wiring

Code: Description: Failure of the heating return sensor (SRR)

rb

Corrective action: Check the efficiency of the sensor and/or wiring

Code: Description: Mains voltage < 190 Vac

LL

Corrective action: Check that the mains voltage is <190 Vac, if the mains voltage is correct replace the control board.

Code: Description: Over high temperature detected by the heating sensor (SR) (>95°C)

Ht

Corrective action: Check the system's water circulation

Code: Description: Insufficient gas pressure

GP

Corrective action: Check the pressure; if the pressure is correct check the efficiency of the gas pressure switch and/or the wiring.

Code: Description: Loss of flame signal during boiler operation

LF

Corrective action: Press the reset key on the panel

Code: Description: Difference between the heating temperature sensor (SR) and the heating return sensor (SRR) > 35°C.

dt

Corrective action: Check the installation

Code: Description: No flame detected during the ignition phase.

Corrective action: Press the reset key on the control panel

Fault finding

Code: Description: Modulating fan failure
FL Corrective action: Check the fan's wiring

Code: Description: Modulating fan failure
FH Corrective action: Check the fan's wiring

Code: Description: Lack of water (only for pump equipped with SensorLogic)
LP Corrective action: Fill-up the water circuit

Code: Description: Main heat exchanger frozen
Fr Corrective action: Carefully de-frost the exchanger

Code: Description: Intervention of the high limit thermostat (TL)
HL Corrective action: Press the reset key on the control panel

Code: Description: Heating sensor failure
Hb Corrective action: Check the sensor's efficiency and/or wiring

Code: Description: Alteration of the operating parameters caused by EMC disturbances
FP Corrective action: Restore the factory parameters

Code: Description: Flame signal detected before the ignition cycle
Fd Corrective action: Disconnect the detection electrode's wire from the control board; if the error code disappears replace the cable, otherwise replace the control board.

Code: Description: Flame detected after burner OFF
GL Corrective action: Disconnect the gas valve's wire from the control board; if the error code disappears replace the control board, otherwise replace the gas valve.

Code: Description: Internal failure
IF Corrective action: Replace the control board

5.2 - DISPLAY OF ERROR CODES ON HEATING CONTROLLER E8

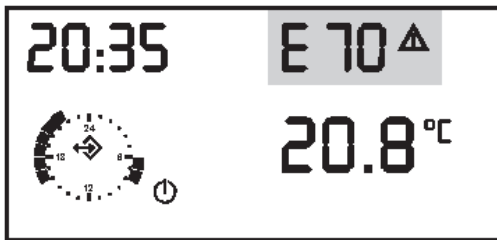

In case of fault, on the display of the regulator a blinking triangle with its error code will appear

Here below you will find the E8 error codes, the relevant meaning and corrective actions.

Cod: *Mining:*

- E01** Intervention of the high limit thermostat (TL)
- E02** Insufficient gas pressure
- E04** No flame detected during the ignition phase
- E05** Lost of the flame signal during the operation
- E06** Too high water temperature detected by the heating sensor (SR) (> 95°C)
- E08** Lack of water
- E10** Internal fault
- E11** Flame detected before the starting of the ignition cycle
- E12** Fault at the heating flow sensor (SR)
- E13** Fault at the DHW sensor
- E14** Fault at the heating return sensor (SRR)
- E15** Temperature difference between heating flow temp. sensor (SR) and heating return temp. sensor (SRR) is > 35K
- E16** Boiler water is frozen
- E20** Flame detected after burner extinction
- E24** Modulating fan speed failure: it doesn't reach the correct speed within 30 s from starting of burner ignition cycle

Cod: *Mining:*

- E30** Alteration of the operating parameters caused by EMC disturbances
- E32** Mains supply voltage < 190 Vac
- E69** E8: F5 – Flow temperature sensor heating circuit 2
- E70** E8: F11 – Flow temperature sensor heating circuit 1
- E71** E8: F1 – Lower storage temperature sensor (Buffer)
- E72** E8: F3 – Higher storage temperature sensor (Buffer)
- E75** E8: F9 – Outer temperature sensor (AF)
- E76** E8: F6 – DHW storage temperature sensor (SPF)
- E78** E8: F8 – Boiler temperature sensor (KF)
- E80** E8: F2 – Room temperature sensor heating circuit 1
- E81** E8: EEPROM fault. The invalid value has been replaced by the standard value
- E83** E8: F15 – Room temperature sensor heating circuit 2
- E90** E8: BUS addresses 0 and 1. The BUS codes 0 and 1 cannot be used at the same time.
- E91** E8: BUS code occupied. The set BUS code is already used by another appliance
- E99** E8: Internal failure
- E135** E8: F12 – Lower DHW storage temperature sensor MF2
- E136** E8: F13 – Boiler 2, Manifold 2 MF 3
- E137** E8: F14 – Manifold 1, Multifunction 4.
- E200** E8: Intervention os safety devices (fans rotating at maximum speed) / communication error module 1

schuster®

00335101 - 1ª edizione 01/14

The manufacturer declines every responsibility for the possible inaccuracies if owed to errors of transcript or press. Also reserves the right to bring those changes that it will hold necessary to its own products or profits, without jeopardizing its essential characteristics.

Schuster - via Padana Inferiore 52/C - 29012 Caorso (PC) - Italy - e-mail: info@schusterboilers.com - www.schusterboilers.com