

DE OR 1



LOW PRESSURE STEAM BOILER, THREE PASS REVERSE FLAME, EFFICIENCY UP TO 91%

RANGE	da 69.8 kW (100 kg/h) a 2683 kW (4000 kg/h)								
TYPE	OR								
	smooth pipe								
FUEL	gas, light & heavy oil								
DESIGN PRESSURE	0.98 bar								
DESIGN TEMPERATURE	119.6°C								
MODELS	100	140	160	200	300	400	500	600	800
	1000	1250	1500	1750	2000	2500	3000	3500	4000

DESCRIPTION

Low pressure steam boiler, three pass reverse flame, smooth pipes with turbulators, 91% efficiency ⁽¹⁾.

DE OR 1 is a family of packaged smoke tube steam boilers, three pass reversed flame, wet back. Standard safety pressure up to 0.98 bar and output from 100 to 4000 kg/h. It can be operated with liquid or gaseous fuels. Every model is complete with regulations and safety accessories for automatic operation and easy commissioning. In compliance to the current laws, each steam boiler undergoes a conformity assessment, carried out by a Notified Body. The conformance to the essential safety requirements demanded by the European Pressure Equipment Directive 2014/68/UE (PED) is guaranteed by the CE mark.

Design features:

By means of the reverse flame principle the smoke gases in the combustion chamber are diverted to the front, then reversed again to the smoke tube sections and discharged through the chimney connection. The appliance is designed to ensure low heating loads in the combustion chamber and low superficial loads.

■ **Boiler body:** is made up of a cylindrical shell and a wet back furnace, made of high quality steel. All the materials have certificates attesting their chemical and mechanical characteristics, the controls are carried out during each production stage, and, their suitability for use as well. The welding seams are carried out by qualified personnel in compliance to certified procedures and are subjected to Non Destructive Tests, in accordance to an internal "Manufacturing and Control" program. Once the boilers have been manufactured they are subjected to hydraulic testing in accordance to the requirement 7.4 – Annex I, laid down in the Directive 2014/68/UE (PED).

■ **Smoke tubes:** made of high quality steel, are welded to tube plates. Pipes are equipped with helical turbulators.

■ **Front door:** is built in welded steel plate, completely clad internally with a layer of insulation material and with a layer of high density refractory material. The door is fitted with hinges which enable it to be easily adjusted and quickly opened. Moreover, the door is fitted with a self-cleaning sight glass for combustion control during boiler operation.

■ **Rear smoke-box:** is built in welded steel plate and fixed on to the tube plate by nuts for an easy access to it. It is fitted with a small door for cleaning purposes and the horizontal flue connection (vertical on request), with a diameter sized to the boiler's output. The rear smoke-box can be accessorized with an external economizer.

■ **The base:** is built with a steel frame, welded to the tube plates and closed with steel plates.

■ **Walkway:** positioned on the top part of the boiler, is made of steel, covered with chequered plate and completed; on request with handrail and access ladder.

■ **Insulation:** the shell is thermally insulated with a 100 mm rock wool cladding bonded with high density, thick thermosetting resins, suitably supported and covered externally in 10/10 thick enamelled aluminum.

Standard equipment: ⁽²⁾

- Steam main globe valve.
- n. 2 spring loaded safety valves.
- n. 2 reflecting level indicators, with flanged connections, purging and cut-off cocks.
- n. 1 large manometer with 3 way cock for manometer calibration.
- n. 1 safety pressure switch with manual reset onto the board panel, CE PED certified.
- n. 1 limit working pressure switch.
- n. 1 regulation pressure switch for two stages burners or probe for modulating burners.
- n. 2 safety minimum level switches, with manual reset CE certified.
- n. 2 water level probes for ON-OFF pump regulation.
- Feeding group complete with 2 centrifugal pumps.
- Valve assembly for feeding circuit, with relevant pipes already fitted.
- Automatic group for level control.
- n. 1 manual bottom blowdown valve.
- Man-hole on top and hand-hole on water side.
- Integral steam drier for high steam quality.
- Blind burner plate.
- Carbon steel turbulators.
- Lifting lugs.
- Control board panel IP55 400V - 3+N - 50Hz
- Document folder enclosing:
 - Manufacturer's Declaration of Conformity in compliance with the Annex VII of the European Directive 2014/68/UE (PED)
 - Installation, operation and service manuals.
 - Certificates of safety components.
 - Control board's electric schemes and related Declaration of Conformity.
 - Water characteristics: requirements concerning the quality of water supply, the water in the boiler, frequency and type of sample tests to do.

Options:

- Spring actuated safety valve
- Kit of "Second boiler water feeding pump"
- Kit of "maximum safety level"
- Kit TDS (Total Dissolved Salts)
- Kit of "Automatic de-sludging" (Blow down)
- Kit of "72 hr exemption" for standard steam boiler
Supplied with electronic board panel Schuster, model IML (Industrial Multi Logic) or IMC
- Pre-drilled burner plate
- Oil or gas fired burner

(1) This value is intended without economizer and may change according working pressure and load conditions.

(2) The quantity and the model may vary according to the configuration.

MAIN COMPONENTS

1. Boiler body
2. Front door
3. Board Panel
4. Instruments assembly
5. Steam valve
6. Safety valve
7. Rear smoke chamber
8. Drain
9. Pump feeding group
10. TDS connection
11. Level gauge

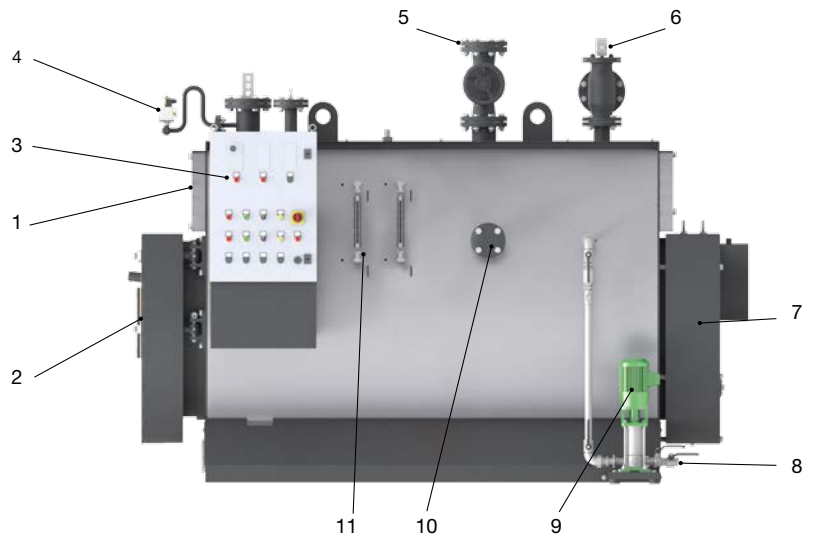

TECHNICAL DATA

Model	Steam production	Nominal output *	Nominal input OR **	ΔP smoke side	Max. working pressure	Water content at level	Total volume	Burner head min. length	Burner head max. dia.
	kg/h	kW	kW	mbar	bar	l	l	mm	mm
100	100	69.8	77.6	1.6	0.98	204	230	240	180
140	140	94	104.4	2.0	0.98	310	410	340	210
160	160	107	118.9	2.3	0.98	310	410	340	210
200	200	134	148.9	2.6	0.98	310	410	340	210
300	300	201	223.3	2.2	0.98	568	730	340	210
400	400	268	297.8	2.6	0.98	568	730	340	210
500	500	335	372.2	2.8	0.98	814	1040	340	240
600	600	402	446.7	3.5	0.98	814	1040	340	240
800	800	537	596.7	3.8	0.98	1160	1545	380	240
1000	1000	671	745.6	4.2	0.98	1160	1545	380	240
1250	1250	838	931.1	4.5	0.98	1663	2250	400	280
1500	1500	1006	1117.8	5.1	0.98	1663	2250	400	280
1750	1750	1174	1304.4	5.5	0.98	2140	2890	420	280
2000	2000	1341	1490.0	6.0	0.98	2140	2890	420	280
2500	2500	1677	1863.3	6.8	0.98	2970	4060	420	360
3000	3000	2012	2235.6	7.0	0.98	2970	4060	420	360
3500	3500	2347	2607.8	7.6	0.98	3490	4770	450	400
4000	4000	2683	2981.1	8.6	0.98	4155	5780	450	400

* with feeding water temperature = 70°C and pressure = 1 bar

** According working pressure and load conditions

PRODUCT PLUS VALUES

EFFICIENT THERMAL INSULATION

given by:

- high total thickness, made by joining two rock wool
- layers with aluminium foil
- insulation between the casing and the hot parts of the boiler body for thermal bridges elimination

REVERSIBLE DOOR OPENING

hinges and closing bolts adjustment in all directions

PLATFORM

in checker plate, placed in the upper part

SIMPLIFIED ELECTRICAL CONNECTION

via fast coupling connectors

BOARD PANELS

electromechanical and electronic, expandable (optional)

POSSIBLE COMBINATION

with one, two, three stage or modulating burners

IMPLEMENTABLE FUNCTIONS

boiler and board panel designed for the integration of optional kits, also with boiler already installed

SMOOTH PIPES

The smooth smoke pipes, suitable for gas, light and heavy oil operation, constituting the tube bundle, increase the thermal exchange and allow the removal of the residual combustion products. They are formed by pipes with, inside, helical turbulators. They are standard supplied for gas, light and heavy oil operation.

TYPE OF PIPES

SMOOTH PIPES

The smooth smoke pipes, suitable for gas, light and heavy oil operation, constituting the tube bundle, increase the thermal exchange and allow the removal of the residual combustion products.

They are formed by pipes with, inside, helical turbulators.

They are standard supplied for gas, light and heavy oil operation.

Efficiency up to 91%.

In function of working pressure of the boiler.



DIMENSIONS

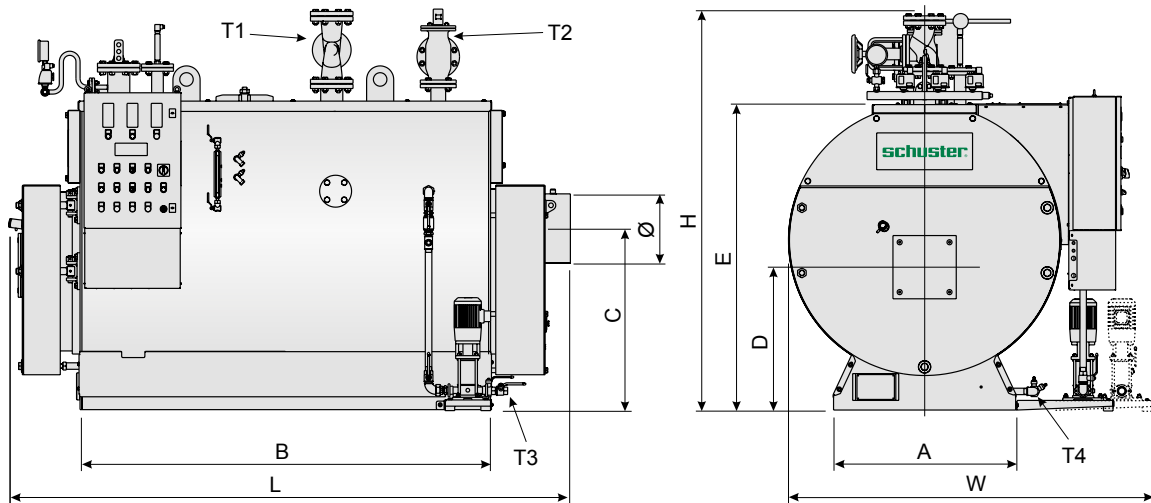

Model	W	L	H	A	B	C	D	E	ø	T1	T2	T3	T4	Empty weight	Total weight
	mm	mm	mm	mm	mm	mm	mm	mm	mm					kg	kg
100	1307	1491	1377	950	880	-	460	971	180	1 1/4"	DN 40	1"	1"	685	889
140	1560	1865	1485	720	1100	725	580	1220	219	DN 50	DN 50	1"	1/2"	1030	1340
160	1560	1865	1485	720	1100	725	580	1220	219	DN 50	DN 50	1"	1/2"	1030	1340
200	1560	1865	1485	720	1100	725	580	1220	219	DN 50	DN 50	1"	1/2"	1030	1340
300	1680	2315	1630	780	1550	815	635	1340	219	DN 65	DN 65	1"	1"	1330	1898
400	1680	2315	1630	780	1550	815	635	1340	219	DN 65	DN 65	1"	1"	1330	1898
500	1800	2515	1800	860	1750	880	685	1460	258	DN 80	DN 80	1"	1"	1630	2444
600	1800	2515	1800	860	1750	880	685	1460	258	DN 80	DN 80	1"	1"	1630	2444
800	1940	2885	1980	950	2120	945	745	1600	358	DN 100	DN 100	1"	1"	2130	3290
1000	1940	2885	1980	950	2120	945	745	1600	358	DN 100	DN 100	1"	1"	2130	3290
1250	2085	3322	2220	1090	2527	1075	860	1790	408	DN 125	DN 125	1"	1"	2740	4403
1500	2085	3322	2220	1090	2527	1075	860	1790	408	DN 125	DN 125	1"	1"	2740	4403
1750	2210	3545	2350	1200	2750	1170	905	1920	408	DN 125	DN 150	1"	1 1/2"	3360	5500
2000	2210	3545	2350	1200	2750	1170	905	1920	408	DN 125	DN 150	1"	1 1/2"	3360	5500
2500	2480	3625	2725	1470	2830	1410	1080	2250	508	DN 150	DN 100 (2x)	1"	1 1/2"	4650	7620
3000	2480	3625	2725	1470	2830	1410	1080	2250	508	DN 150	DN 100 (2x)	1"	1 1/2"	4650	7620
3500	2480	4125	2725	1470	3330	1410	1080	2250	508	DN 150	DN 100 (2x)	1"	1 1/2"	5400	8890
4000	2680	4223	3192	1700	3430	1650	1165	2473	508	DN 200	DN 150 (2x)	1 1/2"	1 1/2"	5900	10055