

SWG

C 24 ec
R 24 ec
C 24 P ec



Provisions for proper disposal of the product in accordance with Directive 2002/96/EC

At the end of its life cycle the product must not be disposed of as urban waste. It can be taken to a special recycling centre managed by the local authorities, or to a dealer who offers this service. Separate disposal of a domestic appliance avoids possible negative consequences for the environment and human health deriving from inappropriate waste handling and allows the recovery of the materials of which it is made, in order to obtain significant energy and resource savings.

Attention: this manual contains instructions for the exclusive use of the professionally qualified installer and/or maintenance technician in compliance with current legislation.
 The user is NOT qualified to intervene on the boiler.
 The manufacturer will not be held liable in case of damage to persons, animals or objects resulting from failure to comply with the instructions contained in the manuals supplied with the boiler.

GENERAL INFORMATION

TECHNICAL FEATURES

INSTALLATION INSTRUCTIONS

MAINTENANCE INSTRUCTION

ENGLISH

1	GENERAL INFORMATION	4
1.1	General warnings	4
1.2	Symbols used in the manual	5
1.3	Appropriate use of appliance.....	5
1.4	Information for system manager.....	5
1.5	Safety warnings.....	6
1.6	Technical data plate.....	7
1.7	Water Treatment.....	8
1.8	Boiler antifreeze protection.....	8
2	TECHNICAL FEATURES AND DIMENSIONS.....	9
2.1	Technical features	9
2.2	Main components view and dimensions.....	9
2.3	Available flow rate / pressure diagram	11
2.4	Operation data.....	12
2.5	General features.....	12
3	INSTALLATION INSTRUCTIONS	13
3.1	General warnings	13
3.2	Installation standards	13
3.3	Preventive system verification and adjustment operations	13
3.4	Packaging.....	14
3.4	Positioning the boiler	15
3.6	Flue gas exhaust pipe connection.....	16
3.7	Connections	19
3.8	Filling the system.....	19
3.9	Electrical connections.....	20
3.10	Commissioning.....	21
3.11	Measurement of combustion efficiency during installation	22
	3.11.1 Unblock button with calibration function.....	22
	3.11.2 Probes positioning	22
3.12	Burner adjustment.....	23
	3.12.1 Electric minimum adjustment.....	25
	3.12.2 Adaptation of the power to the heating system.....	25
4	MAINTENANCE INSTRUCTIONS	26
4.1	Inspection and maintenance instructions	26
4.2	Parameters that can be edited from the control panel	28
4.3	Adaptation of the power to the heating system	29
4.4	Important notes	30
4.5	Wiring diagram	31
4.6	Error codes.....	32

1.1 - GENERAL WARNINGS

The instruction booklet is an integral and essential part of the product and must be kept by the user.

Read the warnings contained in this instruction booklet carefully as they provide important guidelines regarding installation, use and maintenance safety.

Keep the booklet with care for further consultation.

Your appliance must be installed and serviced in compliance with the standards in force according to the manufacturer instructions, up to standard and by legally qualified and certified personnel. Systems for the production of domestic hot water MUST be constructed entirely with compliant materials.

By professionally qualified personnel we mean: personnel with specific technical skill in the field of heating system components for civil use, domestic hot water production and maintenance. Personnel must have the qualifications provided for by current legislation.

Incorrect installation or improper maintenance can cause damage to persons, animals or objects for which the manufacturer is not responsible.

Before performing any cleaning or maintenance, disconnect the appliance from the energy mains by acting on the switch of the system and/or through the specific cut-off devices.

Do not obstruct the terminals of the intake/exhaust ducts.

In the event of failure and/or malfunctioning of the appliance, switch it off and do not try to repair it or intervene on it directly. Contact only personnel qualified in compliance with law.

Any product repairs must be performed solely by personnel authorised, using original spare parts only. Failure to comply with the above can compromise the safety of the appliance and void the warranty.

To guarantee appliance efficiency and its correct operation, yearly maintenance must be performed by qualified personnel.

Should you decide not to use the appliance, parts entailing potential sources of hazard must be made safe.

Before commissioning an appliance that has not been used, wash the domestic hot water production system, making the water flow until it has been fully replaced.

Should the appliance be sold or transferred to a new owner or if you move and leave the appliance, always make sure that the instruction booklet accompanies it in order to be consulted by the new owner and/or installer.

Only original accessories must be used for all appliances with optionals or kits (including electric).

This appliance is intended solely for the use for which it was expressly designed.

Any other use is to be considered improper and therefore dangerous (*).

1.2 - SYMBOLS USED IN THE MANUAL

Pay special attention when reading this manual to the parts marked by the symbols:



DANGER!
Serious danger
to safety
and health



ATTENTION!
Possible dangerous
situation for the product
and the environment



NOTE!
Tips
for the user

1.3 - APPROPRIATE USE OF APPLIANCE



The SWG boiler has been built according to the current level of engineering and acknowledged technical safety rules.

Nonetheless, if improperly used, dangers could arise for the safety and life of the user and other persons or damage to the equipment or other objects.

The appliance is designed to work in heating systems, with hot water circulation, for the production of domestic hot water.

Any other use must be considered improper.

The manufacturer will not be held liable for any damage resulting from improper use.

Use according to the intended purposes also includes strict compliance with the instructions in this manual.

1.4 - INFORMATION PROVIDED TO THE USER



The user must be instructed concerning the use and operation of his heating system, in particular:

- Deliver these instructions to the user, as well as other documents concerning the appliance inserted in the envelope inside the packaging. **The user must keep this documentation safe for future consultation.**
- Inform the user about the importance of the air vents and the flue gas exhaust system, highlighting their essential features and the absolute prohibition of modifying them.
- Inform the user concerning controlling the system's water pressure as well as operations to restore it.
- Inform the user concerning correct temperature control, control units/thermostats and radiators for saving energy.
- Please note that, in compliance with the standards in force, the inspection and maintenance of the appliance must be carried out in compliance with the regulations and frequency indicated by the manufacturer.
- Should the appliance be sold or transferred to a new owner or if you move and leave the appliance, always make sure that the instruction booklet accompanies it in order to be consulted by the new owner and/or installer.

The manufacturer will not be held liable in the event of damage to persons, animals or objects resulting from failure to comply with the instructions contained in this manual.

1.5 - SAFETY WARNINGS



ATTENTION!

The boiler must not be used by people with reduced physical, sensory and mental abilities, without experience and knowledge. These people must be previously trained and supervised during the manoeuvre operations. Children must be supervised so that they do not play with the appliance.



ATTENTION!

The appliance must be installed, adjusted and maintained by professionally qualified personnel, in compliance with the standards and provisions in force. Incorrect installation can cause damage to persons, animals and objects for which the manufacturer cannot be held responsible.



DANGER!

NEVER attempt performing maintenance or repairs on the boiler on your own initiative. Any work must be done by professionally qualified personnel. We recommend stipulating a maintenance contract.

Insufficient or irregular maintenance can jeopardise the operating safety of the appliance and cause damage to persons, animals and objects for which the manufacturer cannot be held responsible.



Changes to the parts connected to the appliance (once the appliance installation is complete)

Do not modify the following parts:

- the boiler
- the gas, air, water and electricity supply lines
- the flue gas pipe, the safety valve and the exhaust pipe
- the construction parts which affect the operating safety of the appliance



Attention!

To tighten or loosen the screwed fittings, use only appropriate fixed spanners. Incompliant use and/or inappropriate tools can cause damage (e.g. water or gas leakage).



ATTENTION!

Indications for propane gas-fired appliances

Make sure that the gas tank has been deaerated before installing the appliance.

For state-of-the-art tank venting, contact the LPG supplier or person qualified in compliance with the law requirement.

If the tank has not been professionally deaerated, ignition problems could arise.

In that case, contact the supplier of the LPG tank.



Smell of gas

Should a smell of gas be perceived, follow these safety guidelines:

- do not turn electric switches on or off
- do not smoke
- do not use the telephone
- close the gas shut-off valve
- air out the area where the gas leakage has occurred
- inform the gas supplier or a company specialised in installation and maintenance of heating systems.



Explosive and easily flammable substances

Do not use or store explosive or easily flammable materials (e.g. petrol, paints, paper) in the room where the appliance is installed.

1.6 - TECHNICAL DATA PLATE

CE marking

The CE marking certifies that the boilers meet:

- The essential requirements of the gas appliance directive (directive 2009/142/EEC)
- The essential requirements of the electromagnetic compatibility directive (2004/108/EEC)
- The essential requirements of the efficiency directive (92/42/EEC)
- The essential requirements of the efficiency directive (directive 2006/95/EEC)



The technical data plate is located inside the boiler on the back at the bottom

CE 1		
2		
Model 3	CEE 92/42 ★ 4	
S.N° 5	PIN 6	
Types 7	NOx 8	
A Central Heating		
Pn 9 kW	Pcond 10 kW	
Qmax 11 kW	Adjusted Qn 12 kW	
PMS 13 bar	T max 14 °C	
B Domestic hot water		
Qnw 15 kW	D 16 l/min	
R factor 17	F factor 18	
PMW 19 bar	T max 20 °C	
C Electrical Power supply		
21 V Hz	22 W	
IP class: 23		
D Countries of destination		
24	25	26
E Factory setting		
27 mbar <input type="checkbox"/>		
mbar <input type="checkbox"/>		
mbar <input type="checkbox"/>		
mbar <input type="checkbox"/>		
mbar <input type="checkbox"/>		
mbar <input type="checkbox"/>		
mbar <input type="checkbox"/>		
28		

KEY:

- 1 = CE monitoring body
- 2 = Type of boiler
- 3 = Boiler model
- 4 = Number of stars (directive 92/42 EEC)
- 5 = (S.N°) Serial Number
- 6 = P.I.N. Product Identification Number
- 7 = Types of approved flue gas exhaust configurations
- 8 = (NOx) NOx Class

- A = Heating circuit characteristics
- 9 = (Pn) Effective nominal output
- 10 = (Pcond) Effective output in condensation
- 11 = (Qmax) Maximum heat output
- 12 = (Adjusted Qn) Adjusted for rated heat output
- 13 = (PMS) Max. heating operating pressure
- 14 = (T max) Max. heating temperature

- B = Domestic hot water circuit characteristics
- 15 = (Qnw) Rated heat output in domestic hot water function (if different to Qn)
- 16 = (D) Specific D.H.W. flow rate according to EN 625 - EN 13203-1
- 17 = (R factor) No. of taps according to the declared amount of water (EN 13203-1)
- 18 = (F factor) No. of stars according to the declared quality of the water (EN 13203-1)
- 19 = (PMW) Max. domestic hot water operating pressure
- 20 = (T max) Max. domestic hot water temperature

- C = Electrical characteristics
- 21 = Electrical power supply
- 22 = Consumption
- 23 = Protection rating

- D = Countries of destination
- 24 = Direct and indirect countries of destination
- 25 = Gas category
- 26 = Supply pressure

- E = Factory settings
- 27 = Adjusted for gas type X
- 28 = Space for national brands

1.7 - WATER TREATMENT



The treatment of the supply water allows to prevent inconveniences and maintain the functionality and efficiency of the generator over time.



The ideal water pH in heating systems must be within:

VALUE	MIN	MAX
PH	6.5	8
Hardness [°fr]	9	15



To minimise corrosion, it is crucial to use a corrosion inhibitor; in order for it to work properly, the metal surfaces must be clean.

(see system protection ACCESSORIES sect. in domestic price list)



ATTENTION!
ANY DAMAGE TO THE BOILER CAUSED BY THE FORMATION OF FOULING OR BY CORROSIVE WATER WILL NOT BE COVERED BY THE WARRANTY.



ATTENTION (*) see general warnings 1.1:

The heating only models are NOT suitable for the production of water for human consumption according to Ministerial Decree D.M. 174/2004.

1.8 - BOILER ANTIFREEZE PROTECTION

To activate the antifreeze function, position the two knobs as shown in the figure.

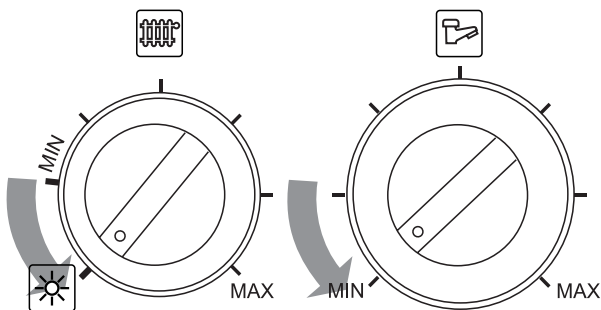

This protection can intervene only if the electricity and gas supplies are connected.

If one of the two is not available and upon reset 11 (SR) a temperature of $< 2^{\circ}\text{C}$ is detected, the appliance will behave as described in tab. pos 2.



The heating system can be protected effectively from frost by using antifreeze products with inhibitor for heating systems.

Do not use car engine antifreeze products as they could damage the water gaskets.

POS	ANTIFREEZE FUNCTION				
	Power supplies		11 - SR (*)	Status function antifreeze	Actions
	Electric	Gas			
1	ON	ON	$< 6^{\circ}\text{C}$	ON	- Burner and Pump ON until $T > 14^{\circ}\text{C}$
2	ON	OFF	$< 2^{\circ}\text{C}$	ON	Only when both the power supplies are ON: - Burner and Pump OFF until $T > 5^{\circ}\text{C}$ - When $T > 5^{\circ}\text{C}$ then Burner and Pump ON until $T > 14^{\circ}\text{C}$.
	OFF	ON			
	OFF	OFF			

(*) Sensor 11 par. 2.2

2.1 - TECHNICAL FEATURES

2.2 - VIEW WITH THE INDICATION OF THE MAIN COMPONENTS AND DIMENSIONS

SWG C 24 ec

SWG C 24 P ec

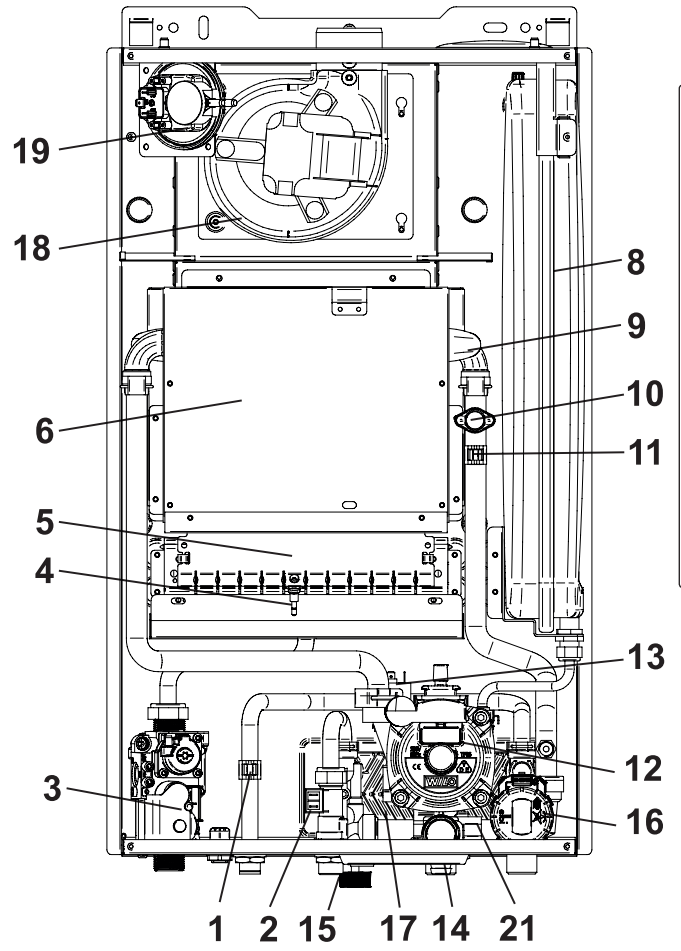
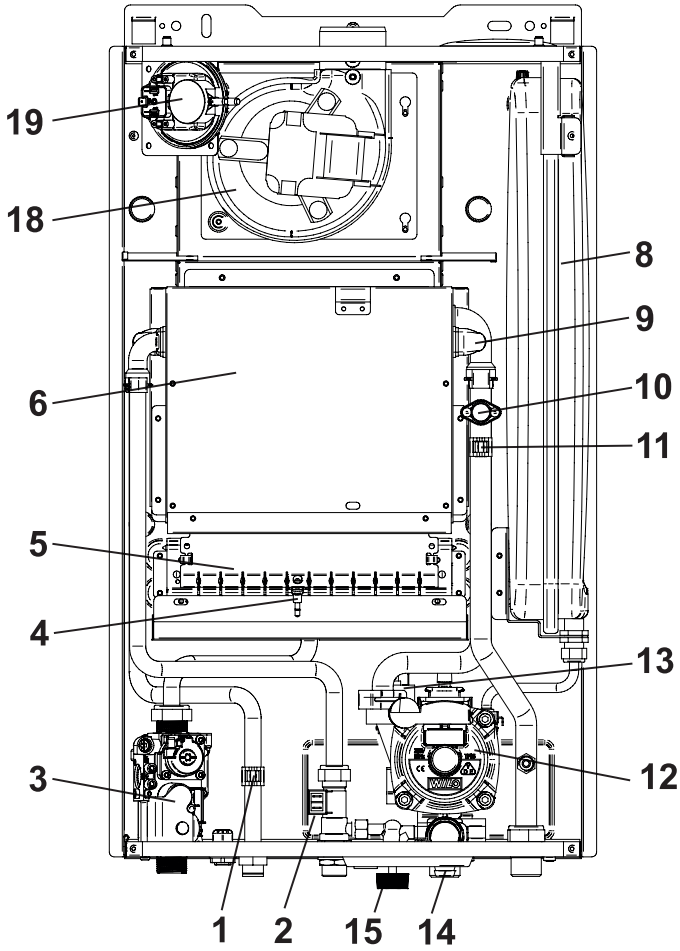

TECHNICAL FEATURES

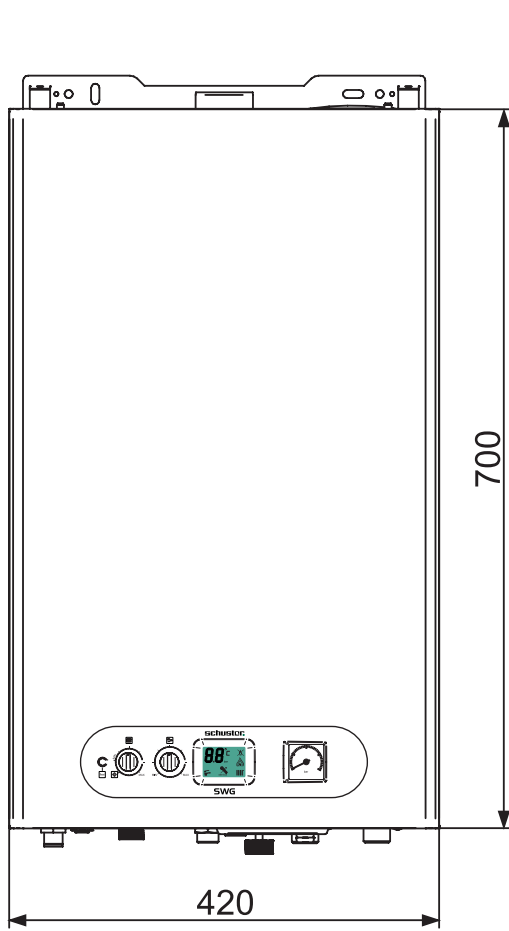

View from above

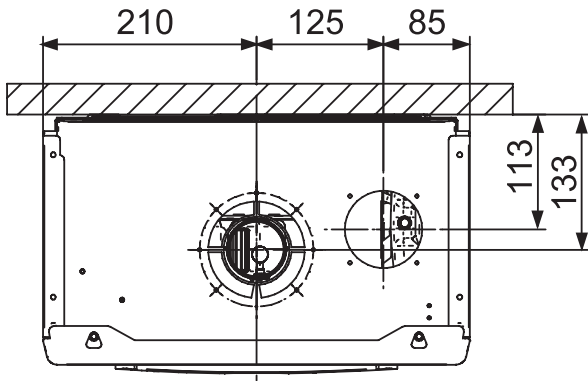

View from below

SWG C 24 ec

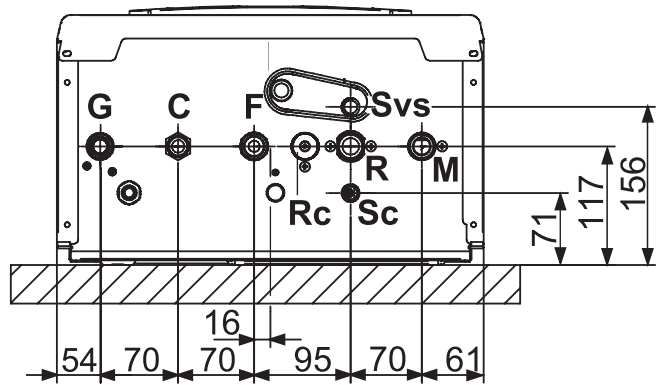

!SWG C 24 P ec

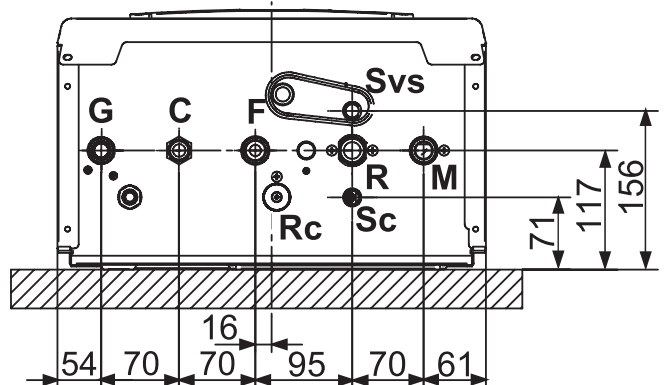

KEY			
No.	C.E.	S.E.	Description
1	db	SS	Domestic hot water temperature sensor
2		FLS	Flow switch with cold water filter
3		VG	Gas valve
4	Fd	E. ACC/RIL	Ignition/detection electrode
5			Burner
6			Combustion chamber
7	AF	TF	Flue gas anti-overflow thermostat
8			Expansion vessel
9	FR HT		Heat exchanger
10	HL	TL	Safety thermostat
11	Hb	SR	Heating temperature sensor
12	Ht	P	Pump
13	Lp	DK	Water deficiency pressure switch
14			Boiler drain valve
15			Filling valve
16			Diverter valve

17			Plate heat exchanger	
18	FL FH	VM	Fan	
19	AF AS	PV	Flue gas pressure switch	
20			Safety valve	
21			Automatic by-pass	
C			Domestic hot water outlet	G ½
G			Gas inlet	G ¾
F			Cold water inlet	G ½
M			Heating system flow	G ¾
R			Heating system return	G ¾
Rc			Filling valve	
Sc			Boiler drain	
Svs			Safety valve drain	
	C.E.		= ERROR CODES see par. 4.6	
		S.E.	= WIRING DIAGRAM KEY see par. 4.5	

TECHNICAL FEATURES

2.3 - DIAGRAM OF FLOW RATE/PRESSURE AVAILABLE FOR INSTALLATION

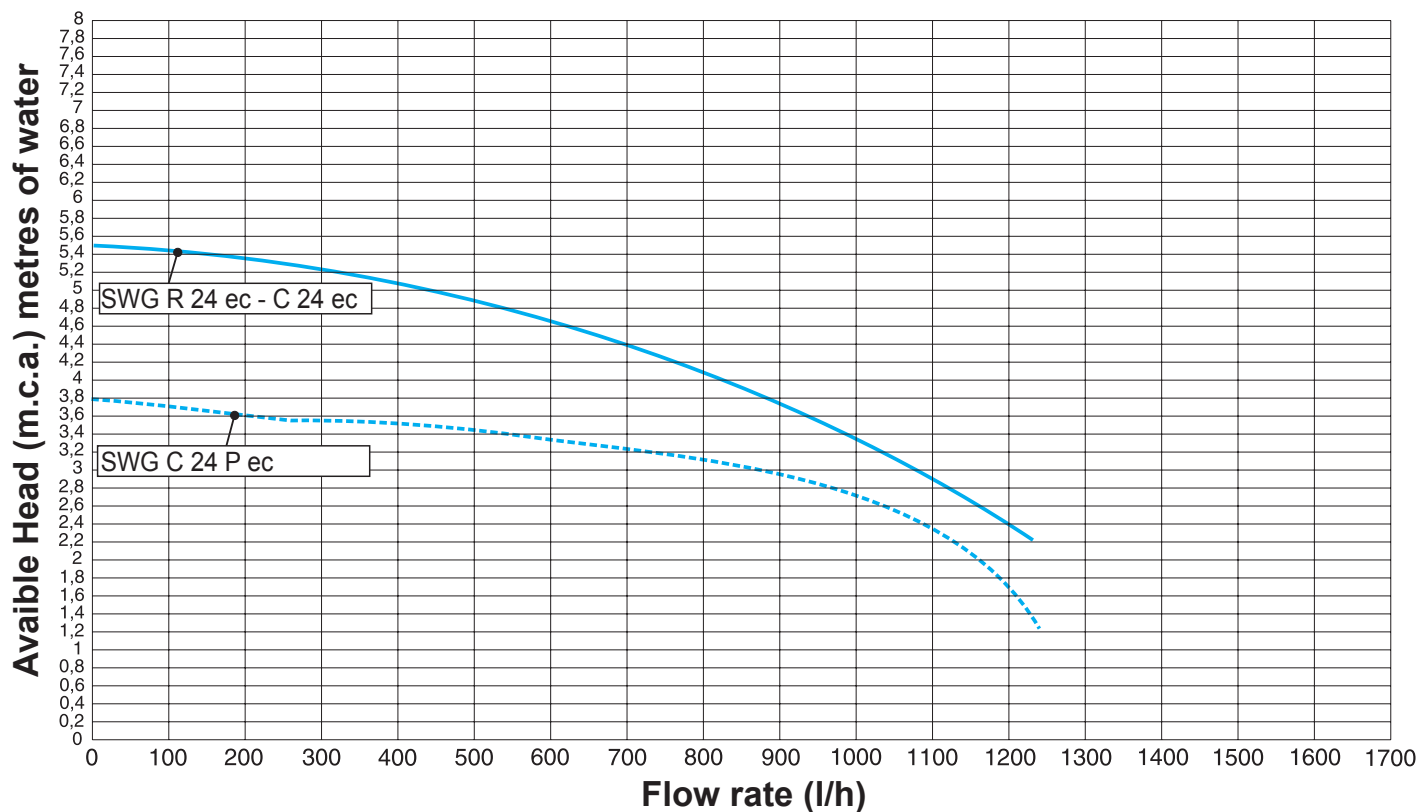

2.4 - OPERATING DATA ACCORDING TO UNI 10348

For the adjustment data: NOZZLES - PRESSURE - DIAGRAMS - FLOW RATES - CONSUMPTION refer to the paragraph ADAPTATION TO OTHER TYPES OF GAS.

	SWG	C 24 ec / R 24 ec	C 24 P ec
Maximum thermal flow rate	kW	26,5	26,5
Minimum thermal flow rate	kW	11,5	11,5
Effective nominal output	kW	24,6	24,7
Minimum effective output	kW	10,1	10,1
Effective efficiency at nominal load (100%)	%	92,92	93,05
Effective efficiency required (100%)	%	92,78	92,78
Effective efficiency at 30% load	%	90,23	90,43
Effective efficiency required (30%)	%	90,17	90,18
Number of stars (according to 92/42 EEC)	n.	★★★	★★★
Combustion efficiency with nominal load (100%)	%	93,72	93,21
Combustion efficiency with reduced load	%	88,92	88,06
Heat loss at casing (min.-max.)	%	0,86-0,80	0,17 - 0,16
(*) Flue gas temperature t_f-t_a (max.)	%	109	119,3
Flue gas mass flow rate (min.-max)	g/s	14,21-13,89	14,21-13,74
Excess λ air	%	46,94	45,15
CO ₂	%	3,0-7,7	3,0-7,8
NOx (Weighted value according to EN 297/A3 or EN 483)	mg/kWh	178,59	184,16
NOx Class		2	2
Heat loss at chimney with burner on (min.-max.)	%	11,08-6,28	11,94-6,79
Heat loss at chimney with burner off	%	0,354	0,256
Notes: (*) Room Temperature = 20°C		Data detected with appliance running on Methane gas (G20)	

2.5 - GENERAL FEATURES

	SWG	C 24 ec	R 24 ec	CS 24 P ec
Appliance category			II _{2H3P}	II _{2H3P}
Minimum heat. circuit output (Δt 20 °C)	l/min		7,26	7,2
Minimum heating circuit pressure	bar		0,5	0,5
Maximum heating circuit pressure	bar		3	3
Primary circuit content	l		3	3
Maximum operating temperature in heat.	°C		78	78
Minimum operating temperature in heat.	°C		45	45
Expansion vessel total capacity	l		6	6
Expansion vessel pre-load	bar		1	1
Maximum system capacity (max temp. calc.)	l		138	138
Minimum domestic hot water circuit flow rate	l/min.	2,5	-	2,5
Minimum domestic hot water circuit pressure	bar	0,5	-	0,5
Maximum domestic hot water circuit pressure	bar	6	-	6
Domestic hot water specific flow rate (Δt 30 °C)	l/min.	11,5	-	12
Domestic hot water flow rate limiter	l/min.	10	-	10
Production of D.H.W. in continuous operation with Δt 45 K	l/min.	7,6	-	7,4
Production of D.H.W. in continuous operation with Δt 40 K	l/min.	8,6	-	8,3
Production of D.H.W. in continuous operation with Δt 35 K	l/min.	9,8	-	9,5
Production of D.H.W. in continuous operation with Δt 30 K	l/min.	11,4	-	11,0
Production of D.H.W. in continuous operation with Δt 25 K (*)	l/min.	13,7	-	13,2
Temperature adjustable in domestic hot water mode	°C	35-57	-	35-57
Voltage/Frequency electric power supply	V-Hz	230/50		230/50
Fuse on the power supply	A (F)	2		2
Maximum absorbed output	W	138		138
Protection rating	IP	X5D		X5D
Net weight	kg	29,6	28,1	30,1
Gross weight	kg	32,5	31	33
(*) mixed				

Attention: should the boilers be used to heat systems at low temperature (e.g. radiant panels), a mixer valve is required to avoid condensation forming.

3.1 - GENERAL WARNINGS



ATTENTION!

This boiler is intended solely for the use for which it was expressly designed. Any other use is to be considered improper and therefore dangerous.

This boiler heats water at a temperature lower than the atmospheric pressure boiling temperature.



ATTENTION!

If there is dust and/or if there are aggressive/corrosive vapours present in the installation room, the appliance must be protected suitably and must be able to operate independently from the air in the room.



Before connecting the boiler, have professionally qualified personnel:

a) **Thoroughly wash all the piping of the system to remove any residues or impurities which could jeopardise proper operation of the boiler, even from a hygienic point of view.**

b) Check that boiler is set up to operate with the available type of fuel.

This can be seen written on the package and on the technical feature plate;

c) Check that the chimney/flue has an appropriate draught, without any bottlenecks, and that no exhausts from other appliances are inserted, unless the flue has been

implemented to accommodate several utilities according to specific standards and regulations in force. Only after this check can the fitting between the boiler and chimney/flue be mounted;



ATTENTION!

Only mount the appliance on a closed wall, made of non-flammable material, flat, vertical so that the minimum distances required for installation and maintenance can be observed.



The boiler must be connected to a central heating system and/or domestic hot water supply network compatible with its efficiency and output.

3.2 - INSTALLATION STANDARDS

It must be installed by a professionally qualified technician, **who shall take the responsibility of observing all local and/or national laws published in the official journal, as well as the applicable technical standards.**

3.3 - PREVENTIVE VERIFICATION AND VERIFICATION AND ADJUSTMENT OPERATIONS

3.4 - PACKAGING

The **SWG** boiler is supplied completely assembled in a sturdy cardboard box.



After having removed the appliance from the packaging, make sure that the supply is complete and undamaged.



The packaging elements (cardboard box, straps, plastic bags, etc.) **must be kept out of the reach of children as they are potential sources of danger.** The manufacturer will not be held liable for damage to persons, animals or objects due to failure to comply with the instruction above.

As well as the appliance, the packaging contains:

- A DOCUMENTATION ENVELOPE
 - System booklet
 - User operating instructions booklet
 - Instruction booklet for the installer and maintenance engineer
- B - Connection predisposition paper template
- C - 2 rawlplugs for boiler attachment
- D - Flue gas exhaust collector (RS - CS version only)

1

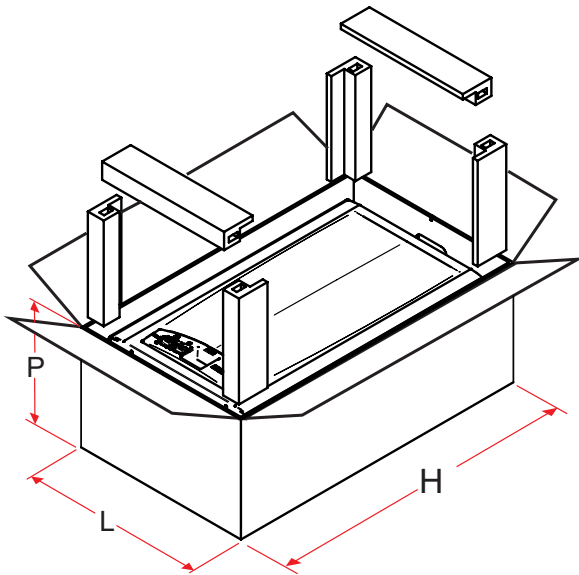

2

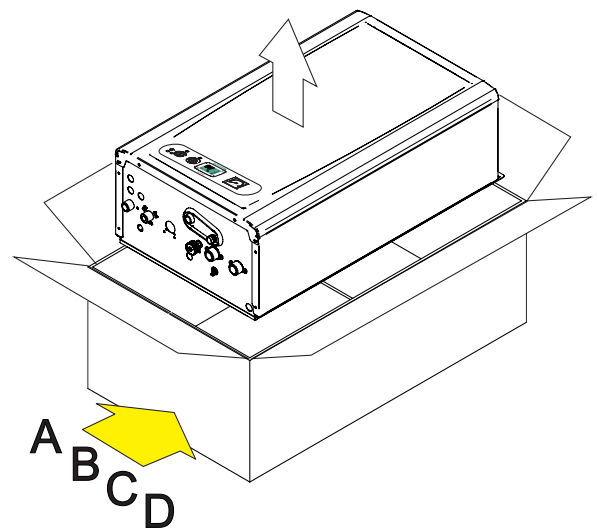

SWG	P depth	L width	H height
24 kW	290 mm	470 mm	810 mm

3.5 - POSITIONING THE BOILER

When choosing the place of the installation of the boiler, follow the safety instructions below:

- Place the boiler in rooms protected from frost.
- Avoid installation in rooms with a corrosive or very dusty atmosphere.
- The appliance must only be installed on a vertical and solid wall which can support its weight.
- The wall must not be made of flammable material.

exhaust pipe do not exceed, in normal operating conditions, a room temperature beyond 60 K, it is not necessary to observe the minimum distances from flammable walls

For boilers with double intake and exhaust pipes, in the event of crossing flammable walls, insert insulation between the wall and the flue gas exhaust pipe.

SWG C/R 24 ec - SWG C 24 P ec

Since the temperature of the wall on which the boiler is installed and the temperature of the coaxial

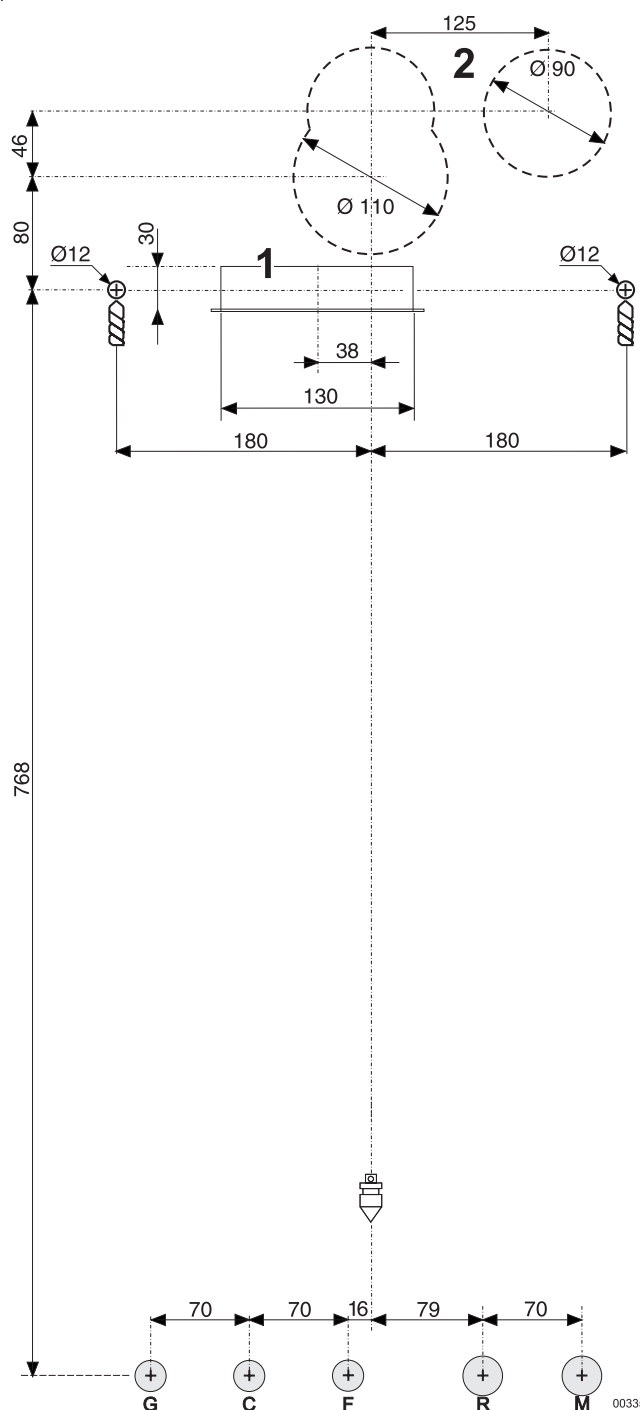
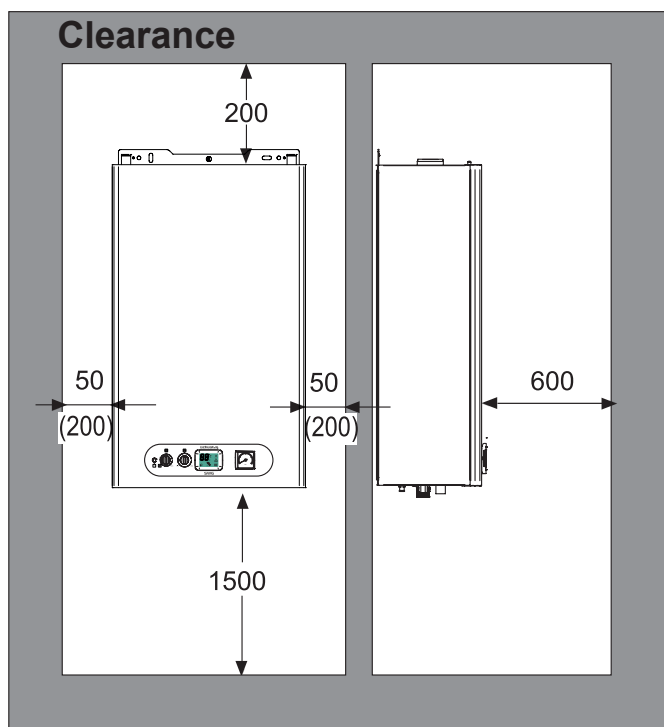

3.6 - FLUE GAS EXHAUST PIPE CONNECTION

FOR BOILERS WITH NATURAL DRAUGHT

Ventilation of the rooms

The boiler must be installed in an adequate room in compliance with the standards in force.

The combustion air is withdrawn directly from the room where the boiler is installed.

Said room must be ventilated in compliance with the standards.

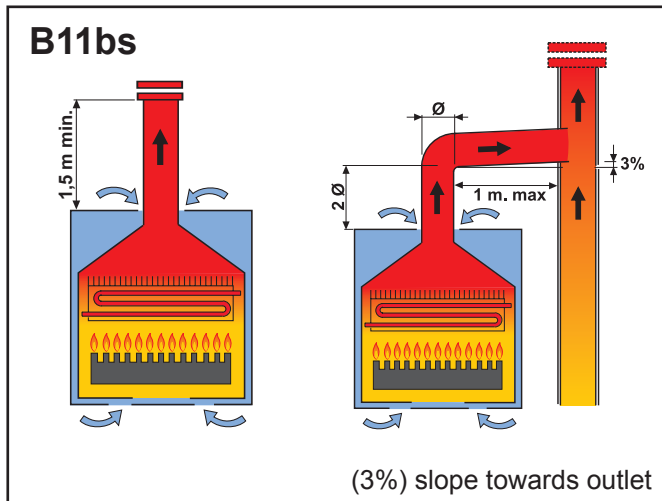

FOR BOILERS WITH FORCED DRAUGHT

To connect the flue gas exhaust pipe, local and national standards must be observed

In the event the boiler is replaced, ALWAYS re-

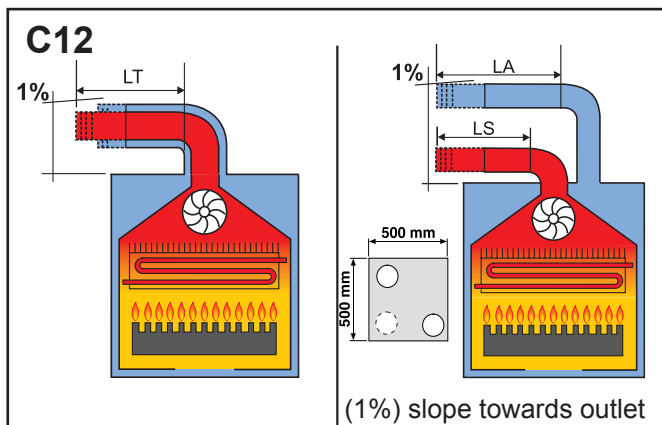

TOTAL LENGTH (LA + LS)					
COAXIAL Ø60/100			DOUBLE Ø80		
COLLECTOR			COLLECTOR		
WITH		WITHOUT	WITH		WITHOUT
FROM [m]	A [m]	UP TO [m]	FROM [Cps]	A [Cps]	UP TO [Cps]
0,5	1	3	1+1	8 + 8	40 (20A+20S)
COAXIAL Ø80/125			DOUBLE Ø60		
COLLECTOR			COLLECTOR		
WITH		WITHOUT	WITH		WITHOUT
FROM [m]	A [m]	UP TO [m]	FROM [Cps]	A [Cps]	UP TO [Cps]
NA	NA	NA	NA	NA	NA
Distance between air inlet pipe and flue gas exhaust pipe: min 250 mm - max 500.					

Horizontal exhaust and intake terminals directed outside via coaxial or double pipes.

NOTE!

Further details in the section "Technical Information"

CAUTION

LT total length is a reference value for the dimensioning of the ducts of A (intake) and S (Exhaust). Subtracting the values of LT reported, at values of bends / terminals / extensions you get the value:

if > 0 = OK - POSSIBLE configuration

if < 0 = NO - WRONG configuration

Cps = Loss coefficient specify

Value referred to curves / terminals / extensions

Ø 60 - Ø 80 wich as to subtracted from LT.

place the flue gas pipe as well.

The boiler is type approved for the exhaust configurations listed below:

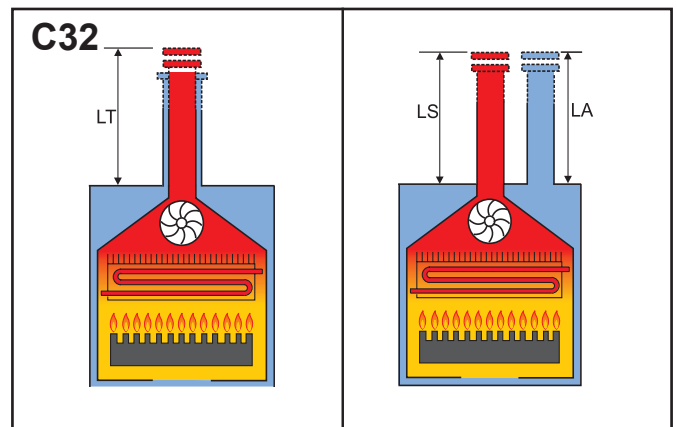

TOTAL LENGTH (LA + LS)					
COAXIAL Ø60/100			DOUBLE Ø80		
COLLECTOR			COLLECTOR		
WITH		WITHOUT	WITH		WITHOUT
FROM [m]	A [m]	UP TO [m]	FROM [Cps]	A [Cps]	UP TO [Cps]
1	2,5	5	3	16	40(20A+20S)
COAXIAL Ø80/125			DOUBLE Ø60		
COLLECTOR			COLLECTOR		
WITH		WITHOUT	WITH		WITHOUT
FROM [m]	A [m]	UP TO [m]	FROM [Cps]	A [Cps]	UP TO [Cps]
0.75	2.5	7	NA	NA	NA

Vertical exhaust and intake terminals directed outside via coaxial or double pipes.

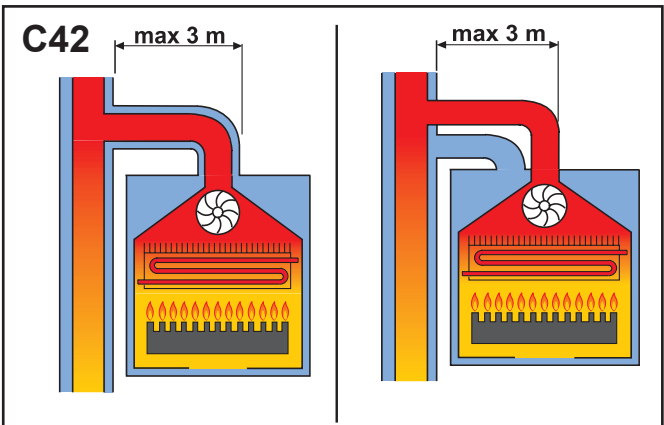

C42 **Collective chimney flue** system, consisting of two pipes, one for combustion air intake and the other one for combustion products evacuation, coaxial or double.

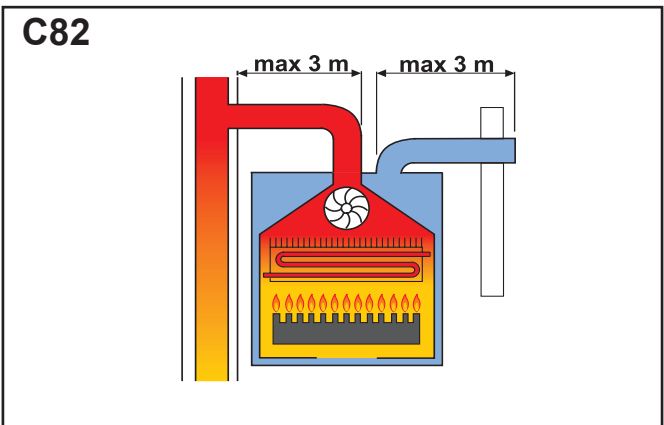

C82 Connection to a terminal for combustion air intake and flue gas exhaust via a single or collective chimney.

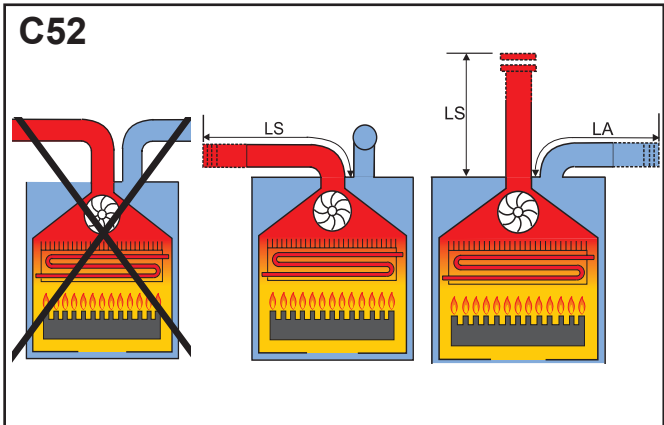

TOTAL LENGTH (LA + LS)					
DOUBLE Ø80 COLLECTOR			DOUBLE Ø60 COLLECTOR		
WITH		WITHOUT	WITH		WITHOUT
FROM [Cps]	A [Cps]	UP TO [Cps]	FROM [Cps]	A [Cps]	UP TO [Cps]
1+1	8+8	40 (20A+20S)	NA	NA	NA

Separate combustion air intake and combustion products evacuation pipes. These pipes can discharge into areas with different pressure.

C62 Boiler intended for connection to a combustion air intake and combustion products evacuation system, approved and sold separately.

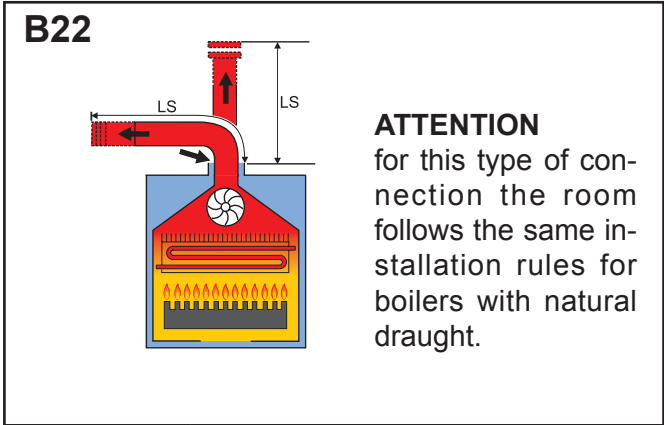

ATTENTION for this type of connection the room follows the same installation rules for boilers with natural draught.

TOTAL LENGTH (LS)		
DOUBLE Ø80 COLLECTOR		
WITH		WITHOUT
FROM [Cps]	A [Cps]	UP TO [Cps]
1	12	20

Connection to a combustion products evacuation pipe outside the room; the combustion air is taken directly from the room where the appliance is installed.

 **ATTENTION:** The flue must comply with standards in force.

GENERAL INFORMATION ON THE FLUE GAS EXHAUST SYSTEM

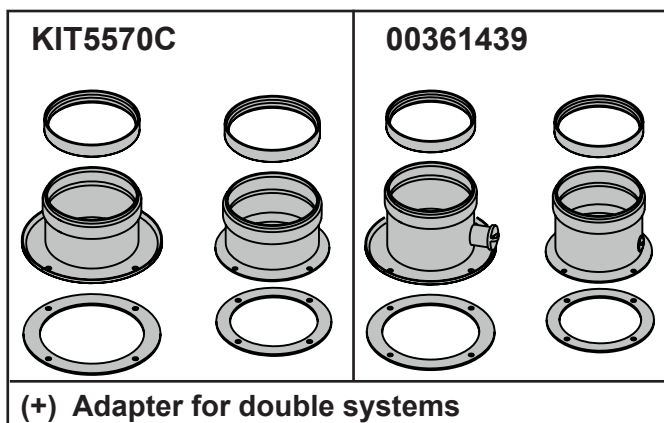
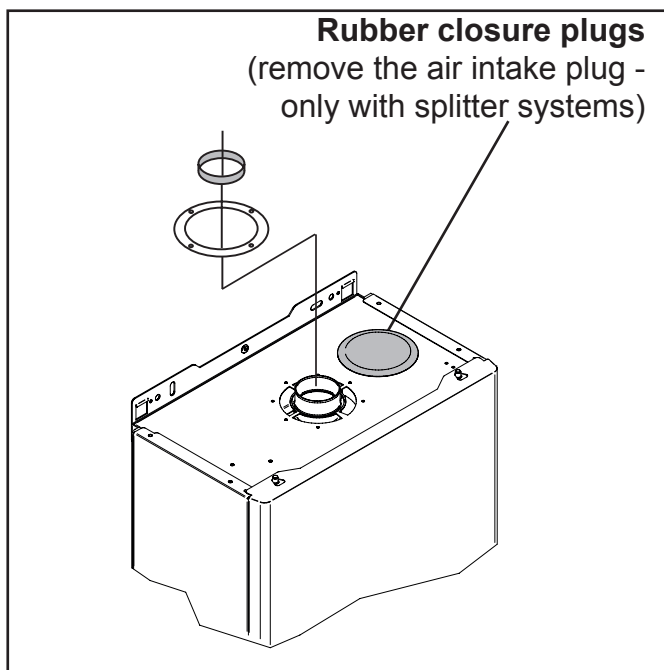
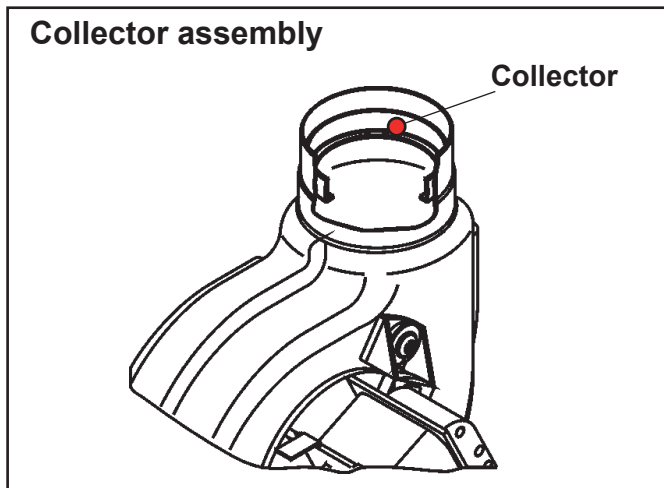

It is recommended to only use original exhaust pipes.
The supplier will have no contractual or extra-contractual liability for damage caused due to incorrect installation and use and in any case failure to comply with the instructions provided by the manufacturer.

3.7 - CONNECTION

G	GAS	3/4"
---	-----	------



Danger!

The gas connection must be carried out only by a qualified installer who must respect and apply that foreseen by relevant laws in force in the local prescriptions of the supply company. Incorrect installation can cause damage to persons, animals and objects for which the manufacturer cannot be held responsible.



If you smell gas:

- Do not operate electric switches, the telephone or any other object that may cause sparks;
- Immediately open doors and windows to create air current to purify the room;
- Shut the gas cocks.

M	FLOW	3/4"
R	RETURN	3/4"

C	HOT	1/2"
F	COLD	1/2"

Sc	BOILER DRAIN
Rc	FILLING VALVE
Svs	SAFETY VALVE DRAIN
	Provide a drain pipe with funnel and a trap that lead to a suitable drain, in correspondence of Svs. This drainage must be controlled on sight. If this precaution is not taken, triggering of the safety valve can cause damage to persons, animals and objects, for which the manufacturer cannot be held responsible.



The mains pressure must be within 1 and 3 bar (in the event of greater pressure install a pressure reducer).



Only for models: **SWG C24 ec**
SWG R24 ec

With the purpose to always assure a minimum water flow through the heat exchanger, also in the case in which all the thermostatic valves, that are on the heating circuit, are closed, foresee the mounting, among the flow and return pipes, of an automatic bypass, or make sure that, at least one radiator of C.H. circuit, is always open. The manufacturer declines every responsibility in the case of damages to people, animals or things, caused by the missed observance of the above statement.

3.8 - FILLING THE SYSTEM



Attention!

Do not mix the heating water with incorrect concentrations of antifreeze or anti-corrosion substances! This could damage the gaskets and cause noise during operation.

The manufacturer will not be held liable for damage to persons, animals or objects due to failure to comply with the above instruction.

When the system connections have been completed, the circuit can be filled.

This operation must be performed carefully, respecting the following phases:

- open the radiator vent valves and make sure the automatic valve is working properly in the boiler.
- open the filling tap gradually, making sure that the automatic air release valves installed on the system work properly.
- close the radiator air release valves as soon as water comes out.
- check the pressure gauge until pressure reaches approximately 0.8/1 bar.
- close the filling tap and bleed air once again through the radiator air release valves.

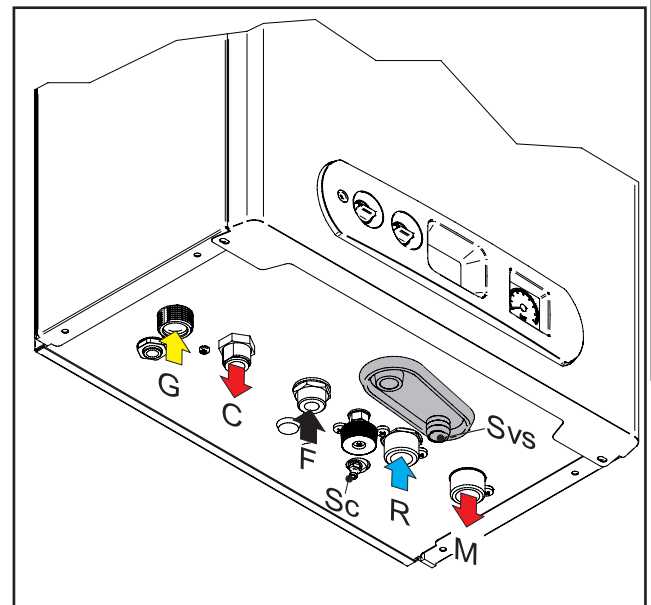

- make sure that all the connections are watertight.
- after commissioning the boiler (see par. 3.10) and bringing the system to the operating temperature, stop the boiler and repeat the air bleed operations.
- let the system cool down and, if necessary, return the water pressure to 0.8/1 bar.
(See par. 4.4).

3.9 - ELECTRICAL CONNECTIONS



Danger!
Only a qualified technician may perform the electrical installation.
Before performing connections or

any type of operation on electrical parts, always disconnect electrical power and make sure that it cannot be reconnected accidentally.

<p>ON/OFF room thermostat connection (*)</p> <p>- Remove the jumper and connect the room thermostat wires between terminals TA 2.</p>	<p>ON/OFF room thermostat connection RT/OT (*)</p> <p>- Connect the modulating thermostat wire between terminals TA1/OT after having removed the jumper.</p>	<p>External probe connection (*)</p> <p>- Predisposed on the terminal board, terminals SE</p>
--	---	--

Electric power supply connection

1,5 m

3xØ0,75

Y/G
L1
N

230 V - 50 Hz



The boiler is equipped with a power cable, boiler installation requires electric al connection to the mains power supply. This connection must be made up to standard, as required the regulations in force.



Remember that a bipolar switch must be installed on the boiler power line with over 3 mm between contacts, easy to access, making maintenance quick and safe.



The power cable must be replaced by authorised technical staff, using original spare parts only. Failure to comply with the above can jeopardise the safety of the appliance.

See par. 4.5 positioning on the board

(*) Optional

3.10 - COMMISSIONING



Commissioning must be done by professionally qualified personnel. The manufacturer will not be held liable for damage to persons, animals or objects due to failure to comply with the above

instruction.

Before commissioning the boiler, check that:

does the installation meet the specific standards and regulations in force, both relating to the gas part as well as the electrical part?	<input type="checkbox"/>
do the combustion air intake and flue gas exhaust take place properly according to what is defined by the specific rules and regulations in force?	<input type="checkbox"/>
is the fuel supply system sized according to the capacity required by the boiler? Is it equipped with all safety and control devices required by the standards in force?	<input type="checkbox"/>
is the power supply of the boiler 230V - 50Hz?	<input type="checkbox"/>
has the system been filled with water (approximately 0.8/1 bar pressure on the pressure gauge with the pump stopped)?	<input type="checkbox"/>
are any system shut-off gate valves open?	<input type="checkbox"/>
does the gas to be used correspond to the boiler calibration gas?: otherwise, perform the boiler conversion in order to use the gas available (see section: 4.3"); this operation must be carried out by technical staff qualified in compliance with the standards in force;	<input type="checkbox"/>
is the gas supply valve open?	<input type="checkbox"/>
has the system been checked for gas leaks?	<input type="checkbox"/>
is the outside main switch ON?	<input type="checkbox"/>
is the system safety valve efficient and is it connected to the drains?	<input type="checkbox"/>
has the system been checked for water leaks?	<input type="checkbox"/>
are the ventilation conditions and minimum distances to perform any maintenance ensured?	<input type="checkbox"/>
have the GAS, HEATING and DOMESTIC HOT WATER pipes been cleaned thoroughly with products suitable for each circuit?	<input type="checkbox"/>
for the models SWG C 24 ec / SWG R 24 ec is a minimum water flow rate always assured to the heat exchanger? (presence of the bypass between the flow and return pipes or, at least, a radiator always open?)	<input type="checkbox"/>
has a surveillance and protection system against gas leaks been installed? (Optional)	<input type="checkbox"/>
are the system pipes NOT used as the electrical system earthing?	<input type="checkbox"/>
has the system been sized properly bearing in mind the radiator pressure drops? thermostatic valves, radiator stop valves	<input type="checkbox"/>
has the operator been trained and has the documentation been supplied?	<input type="checkbox"/>
Please tick the operations performed	

3.11 - MEASUREMENT OF COMBUSTION EFFICIENCY DURING INSTALLATION

3.11.1- ACTIVATION OF THE CALIBRATION FUNCTION





ATTENTION!
Function reserved for Authorised Assistance Centres only.
The user is NOT authorised to ac-

tivate the function described below.



1 ACTIVATION

By pressing the button (D) for 3 seconds, the calibration function is activated. Release it when the SERVICE symbol appears, **Do not press it for more than 9"**
This function is not activated if there is a block or domestic hot water request.

3 MINIMUM OUTPUT

By turning the knob (B) in position ☀, the boiler will operate at **minimum output**:
- 2 illuminated symbols  
- 1 flashing 

2 MAXIMUM OUTPUT

By turning the knob (B) onto MAX, the boiler will operate at **maximum output**:
- 3 illuminated symbols   

4 DISABLING

The "calibration" function stays active for 15 minutes.

To disable the **CALIBRATION** function before the time elapses, switch the boiler on and off again.

3.11.2 - POSITIONING THE PROBES

To determine the combustion efficiency one must make the following measurements:

- measurement of the combustion air temperature taken in the relevant hole **2**.

- measurement of the flue gas temperature and content of CO₂ taken in the relevant hole **1**.

Take the measurements with the generator in steady state conditions (see par. 3.11.1).

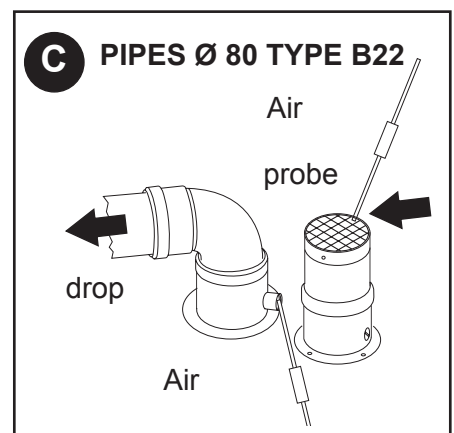
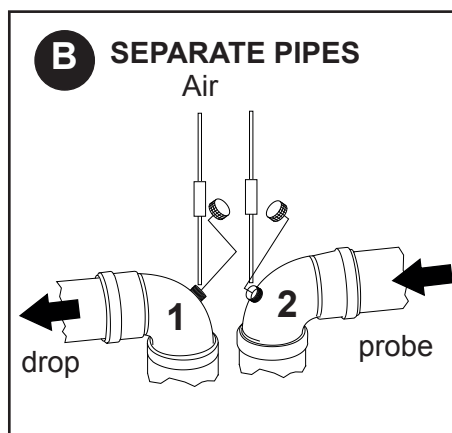
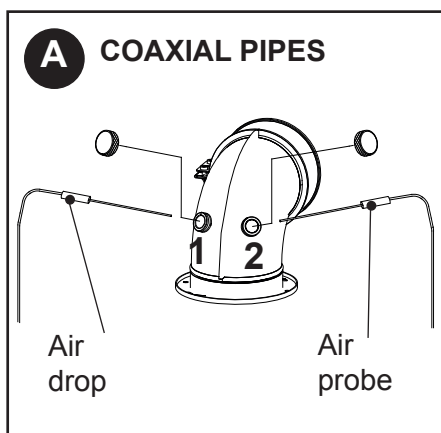

3.12 - ADJUSTING THE BURNER



Attention, during these operations do not take any samples in domestic hot water mode.

All boilers leave the factory already calibrated and tested, however in the event the gas valve recalibration is required:

- Loosen the needle screw "P" located inside the pressure socket at gas valve outlet and connect a pressure gauge with reference to the figure.
- Check the supply pressure value (see NOZZLES - PRESSURES table).



The following instructions are intended exclusively for **authorised service personnel**.

1) Maximum output adjustment

- Operate the boiler in "calibration" mode at MAXIMUM OUTPUT (see 3.11.1).
- Once the burner is on check that the "MAXIMUM" pressure value corresponds to that indicated in the table "NOZZLES - PRESSURE".
- Should it not correspond, correct it by removing the screw cap "Q" and turning screw "S" below CLOCKWISE to increase it, ANTICLOCKWISE to decrease it.

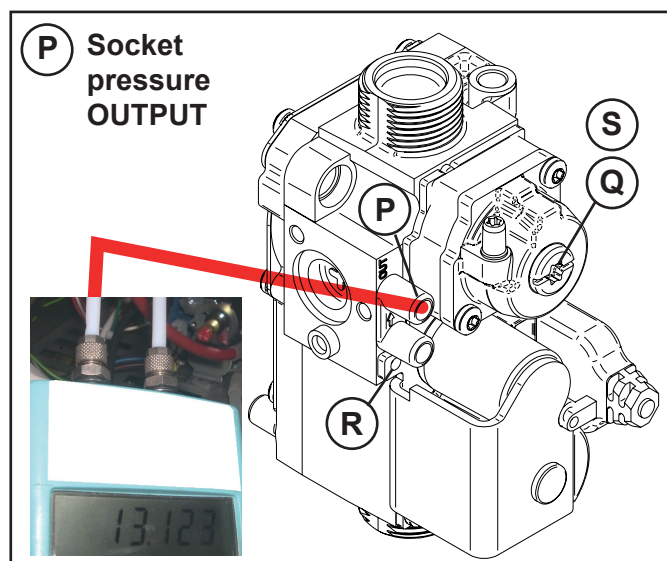

2) Minimum output adjustment

- Operate the boiler in "calibration" mode at MINIMUM OUTPUT (see 3.11.1)
- Once the burner is on, check that the "MINIMUM" pressure value corresponds to that indicated in the table "NOZZLES - PRESSURE".
- Correct it if needed by turning (with a screwdriver) the screw "R"; CLOCKWISE to increase it, ANTICLOCKWISE to decrease it.

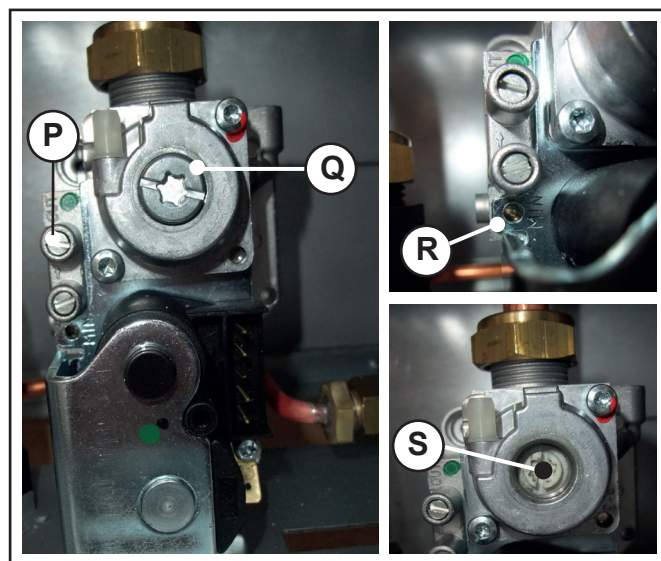

3) Conclusion of the basic calibrations

- once the gas valve minimum and maximum pressure values are checked and top-up is required (points 1-2):
- disable the timed "calibration" function by switching off the main switch.
- **Remove the flexible tube from the pressure gauge and close the pressure socket screw again.**
- **Check that there are no gas leaks.**

NOZZLES - PRESSURE - COLLECTOR TABLE

SWG R 24 ec- SWG C 24 ec										
Type of Gas	Furnace Useful [kW]	Thermal Capacity [kW]	Pressure Press. [mbar]	Ø Nozzles [mm]	Nozzles no.	Ø Collector [mm]	Pressure minimum [mbar]	Pressure operating [mbar]	Consumption min.	Consumption max.
Nat. gas (G20)	10,1- 24,6	11,5 - 26,5	20	1,35	11	-	2,3	12,8	1,22 m³/h	2,80 m³/h
Propane (G31)	10,1- 24,6	11,5 - 26,5	37	0,85	11	-	6,1	33,5	0,89 kg/h	2,06 kg/h
SWG C 24 P ec										
Type of Gas	Furnace Useful [kW]	Thermal Capacity [kW]	Pressure Press. [mbar]	Ø Nozzles [mm]	Nozzles no.	Ø Collector [mm]	Pressure minimum [mbar]	Pressure operating [mbar]	Consumption min.	Consumption max.
Nat. gas (G20)	10,1- 24,7	11,5 - 26,5	20	1,35	11	-	2,3	12,80	1,22 m³/h	2,80 m³/h
Propane (G31)	10,1- 24,7	11,5 - 26,5	37	0,85	11	-	5,8	32	0,89 kg/h	2,06 kg/h

The burner pressures stated in the following table must be checked after 3 minutes of operation and refer to, for models S (TFS), with combustion chamber closed.

3.12.1 - ADJUSTMENT OF THE GAS VALVE ELECTRIC MINIMUM



ATTENTION!
 Function reserved for Authorised Assistance Centres only.
 The user is NOT authorised to activate

the function described below.

1 ACTIVATION
 Activate the MINIMUM POWER calibration function (par. 3.11.1)

2 EDITING THE VALUE

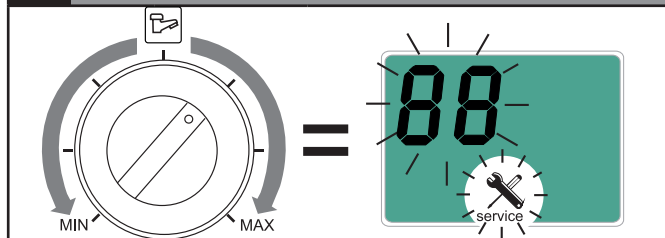

Turn the DOMESTIC HOT WATER knob "C"

GAS VALVE ELECTRIC MINIMUM

VALUES

FROM	A	DEFAULT	
0 (%)	99 (%)	20 (G20)	25 (G31)

3 CONFIRM VALUE



Confirm the value by pressing the unblock key

3.12.2 - ADAPTATION OF THE POWER TO THE HEATING SYSTEM

It is possible to adjust the maximum thermal capacity in heating mode, by decreasing the burner pressure value

1 ACTIVATION
 Collect the pressure gauge differential to measure the burner pressure (see par. 3.12)

2 EDITING THE VALUE
 Modify parameter HP (see par. 4.2) until the value corresponding to the wanted power is obtained.

3 CHECK
 Switch-on the boiler in heating mode.
 Check the pressure on the pressure gauge, based on the requested power, through the chart.

E.g. **SWG C 24 ec**
 to decrease the output of the boiler to 23 kW, obtain a pressure value of 10.3 mbar (read on the pressure gauge), modifying the HP parameter (about 40).

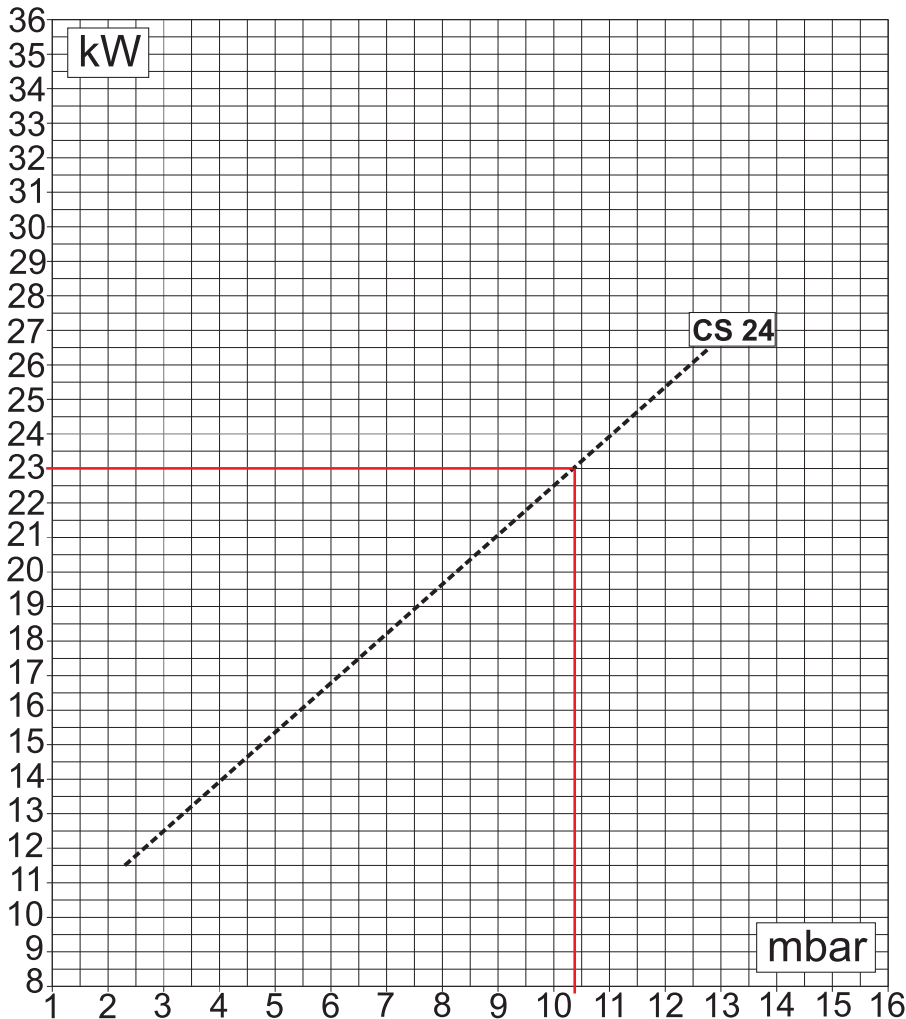

4

INSPECTION AND MAINTENANCE



Inspections and maintenance performed professionally and according to a regular schedule, as well as the use of original spare parts, are of the utmost importance for fault-free operation of the boiler and to guarantee its long life.

The maintenance frequency must comply with standards in force.



Failure to perform Inspections and Maintenance can entail material and personal damage

4.1 - INSPECTION AND MAINTENANCE INSTRUCTIONS

To assure long-term functioning of your boiler and to avoid altering its approved status, only original spare parts must be used.

If a component needs to be replaced:

- Disconnect the appliance from the electrical mains and make sure that it cannot be reconnected accidentally.
- Close the gas shut-off valve upstream the boiler.
- If needed, and depending on the intervention to be carried out, close any shut-off valves on the flow and return line of the heating system, as well as the cold water inlet valve.
- Remove the front casing from the appliance.

Once all maintenance operations are complete resume boiler operation

- Open the heating flow and return pipes, as well as the cold water inlet valve (if closed previously).
- Vent and, if necessary, restore the heating pressure until reaching a pressure of 0.8/1.0 bar.
- Open the gas shut-off valve.
- Switch the boiler back on.
- Make sure the appliance is gas tight and water-tight.
- Remount the front casing of the appliance.

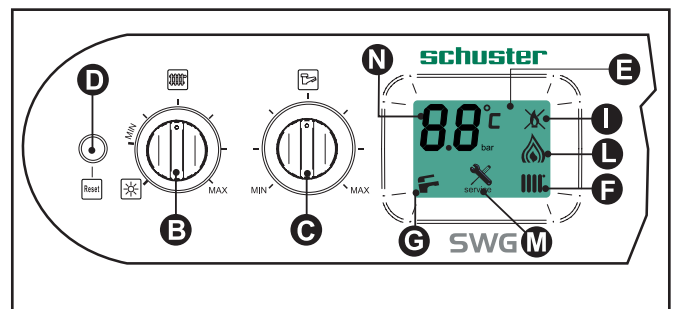

TABLE OF RESISTANCE VALUES, ACCORDING TO THE TEMPERATURE, TO THE HEATING PROBE 11 (SR) AND TO THE DOMESTIC HOT WATER PROBE 1 (SS) AND ANY HEATING RETURN PROBE 22 (SRR) see par. 4.5.

T°C	0	1	2	3	4	5	6	7	8	9
0	32755	31137	29607	28161	26795	25502	24278	23121	22025	20987
10	20003	19072	18189	17351	16557	15803	15088	14410	13765	13153
20	12571	12019	11493	10994	10519	10067	9636	9227	8837	8466
30	8112	7775	7454	7147	6855	6577	6311	6057	5815	5584
40	5363	5152	4951	4758	4574	4398	4230	4069	3915	3768
50	3627	3491	3362	3238	3119	3006	2897	2792	2692	2596
60	2504	2415	2330	2249	2171	2096	2023	1954	1888	1824
70	1762	1703	1646	1592	1539	1488	1440	1393	1348	1304
80	1263	1222	1183	1146	1110	1075	1042	1010	979	949
90	920	892	865	839	814	790	766	744	722	701

Relation between the temperature (°C) and the nom. resistance (Ohm) of the heating probe SR and of the domestic hot water probe SS

Example: At 25°C, the nominal resistance is 10067 Ohm At 90°C, the nominal resistance is 920 Ohm

ROUTINE YEARLY VERIFICATION OPERATIONS		
COMPONENT:	VERIFY:	CONTROL/INTERVENTION METHOD:
FL (domestic hot water priority flow switch) (2)	Is the minimum domestic hot water flow rate 3 l/min.?	The burner must ignite with an intake above or equal to: 3 l/min.
VG (Gas valve) (3)	Does the valve modulate properly?	Open a hot water tap at maximum flow rate and then at minimum. Make sure that the flame modulates.
SR (heating sensor) (11) SS (domestic hot water sensor) (1)	Do the sensors maintain the original characteristics?	12571 ohm at 20° C / 1762 ohm at 70° C. Measurement to be taken with the wires disconnected (see table Res/Temp).
E ACC/RIV. (ignition/detection electrode) (4)	Does the discharge of sparks before putting the boiler in safe conditions last less than 10 sec.?	Detach the electrode ionisation wire and check the securing time.
TL (anti-overheating limit thermostat) (10)	Does the TL put the boiler in safety conditions when overheating?	Heat the TL until it intervenes at 95°C and check that it intervenes at 95°.
DK (safety pressure switch against water deficiency) (13)	Does the pressure switch block the boiler if the water pressure is below 0.4 bar?	Without request: close the shut-off valves of the heating circuit, open the drain valve to make the water pressure decrease. Before pressurising again, check the pressure of the expansion vessel.
Expansion vessel (8)	Does the vessel contain the right amount of air?	Check the nitrogen pressure (1 bar when the boiler is empty). Pressurise the boiler (open the pump automatic vent valve). Open the heating circuit closing valves.
Domestic hot water flow rate	Filter in cold water inlet (2)	Clean the filter with limescale remover.
Heat exchanger body (9)	Check that the space between the rungs of the exchanger are not clogged	Eliminate the deposits without damaging the exchanger, using a soft bristle brush and specific, non flammable detergents.
Burner (5)	Check the state of cleanliness of the burner mesh	Remove deposits using a soft bristle brush and blow on each single ramp from the outside and from the venturi.

(Num) = see key Par. 2.2

4.2 - PARAMETERS THAT CAN BE EDITED FROM THE CONTROL PANEL



ATTENTION!
Function reserved for **Authorised Assistance Centres** only.
Some service parameters can be edited from the control panel:

1 ACTIVATION

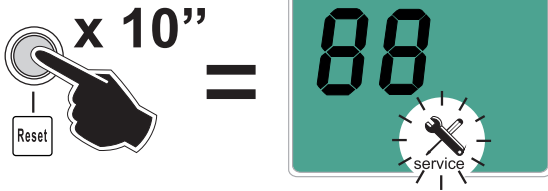

By pressing the button (D) for 10 seconds, the function is activated when the key flashes on the display

2 SELECTION

Turn the HEATING knob "B"

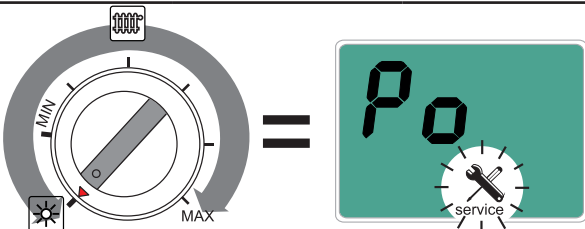

PUMP POST CIRCULATION

VALUES

FROM	A	DEFAULT
0 (5 min)	1 (ALWAYS)	0 (5 min)

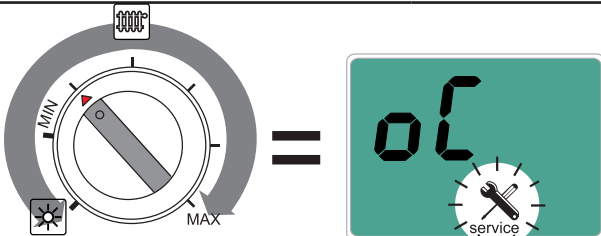

EXTERNAL PROBE TEMPERATURE

VALUES

FROM	A	DEFAULT
0 (- 20°C)	30 (+ 10°C)	20 (0°C)

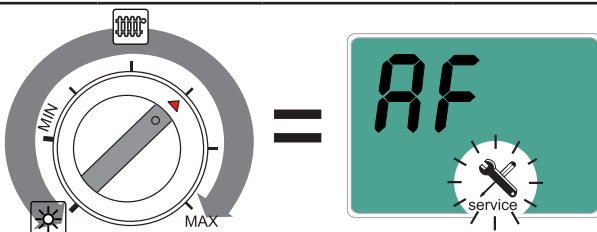

NUMBER OF SWITCH-ONS LIMIT DEVICE

VALUES

FROM	A	A	DEFAULT
0 (*)	1 (minute)	15 (minutes)	0

(*) WITH VARIABLE HYSTERESIS

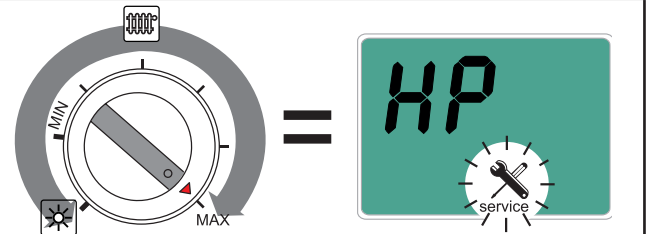

MAXIMUM HEATING OUTPUT

VALUES

FROM	A	DEFAULT
0 (Min)	99 (Max)	99

3 CONFIRM SELECTION



Confirm the parameter to be edited by pressing the unblock key

4 EDITING THE VALUE

Turn the DOMESTIC HOT WATER knob "C"

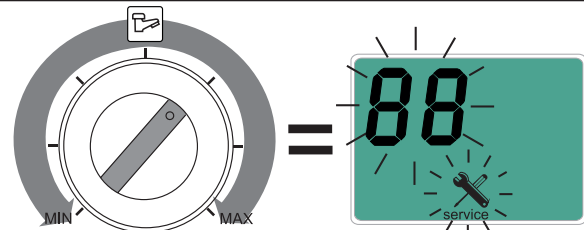

The value flashes on the display

5 CONFIRM VALUE



Confirm the value by pressing the unblock key

6 PARAMETER SELECTION

Go back to section 2.

7 DISABLING

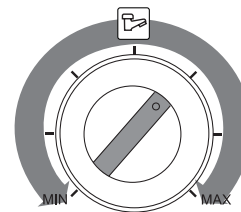

To exit the parameters list wait for 20" or quickly turn the domestic hot water knob "C".

4.3 - ADAPTATION TO THE USE OF OTHER GAS

The boilers are produced for the type of gas specifically requested upon ordering.



DANGER!

The conversion for the operation of the boiler with a type of gas other than that specifically required in the order, must be performed by professionally qualified personnel, in compliance with the standards and regulations in force.

The manufacturer cannot be held liable for any damage resulting from a conversion operation that is incorrect or not performed in compliance with the laws in force and/or with the instructions given.



ATTENTION!

After performing the conversion for the operation of the boiler with a type of gas (e.g. propane gas) other than that specifically requested when ordering, the appliance will only work with this new type of gas.



ATTENTION!

Indications for propane gas-fired appliances

Make sure that the gas tank has been deaerated before installing the appliance.

For state-of-the-art deaeration of the tank, contact the LPG supplier or a person qualified in compliance with law.

If the tank has not been professionally deaerated, ignition problems could arise.

In that case, contact the supplier of the LPG tank.

To convert the boiler from one type of gas to another, proceed as follows:

- Disconnect the appliance from the electrical power supply
- disconnect the detection/switch-on electrode (1), loosen the 4 screws (2) that connects the burner pack (3) to the nozzle collector
- remove the burner (3);

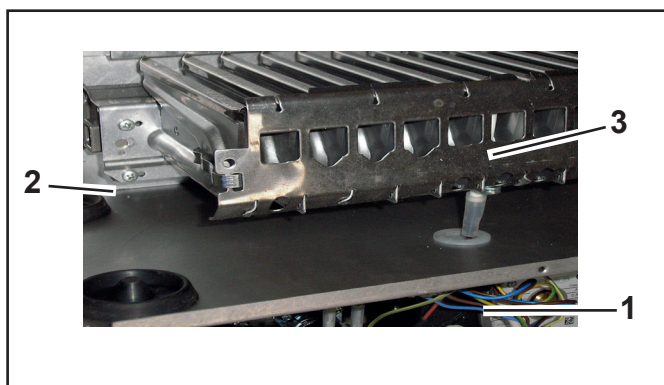

- disconnect the nozzles (4) from the manifold (5) and replace them with those of diameter corresponding to the new gas type (see table "NOZZLES - PRESSURES");

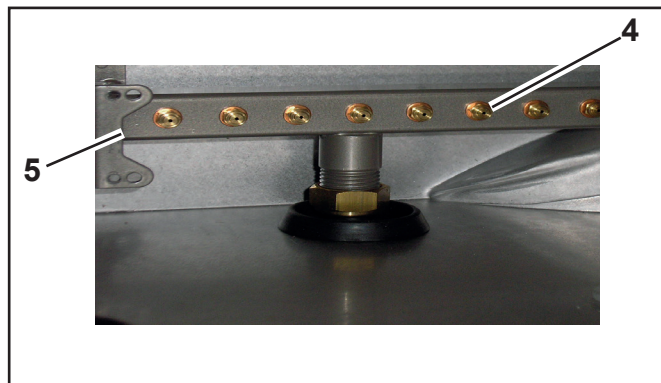

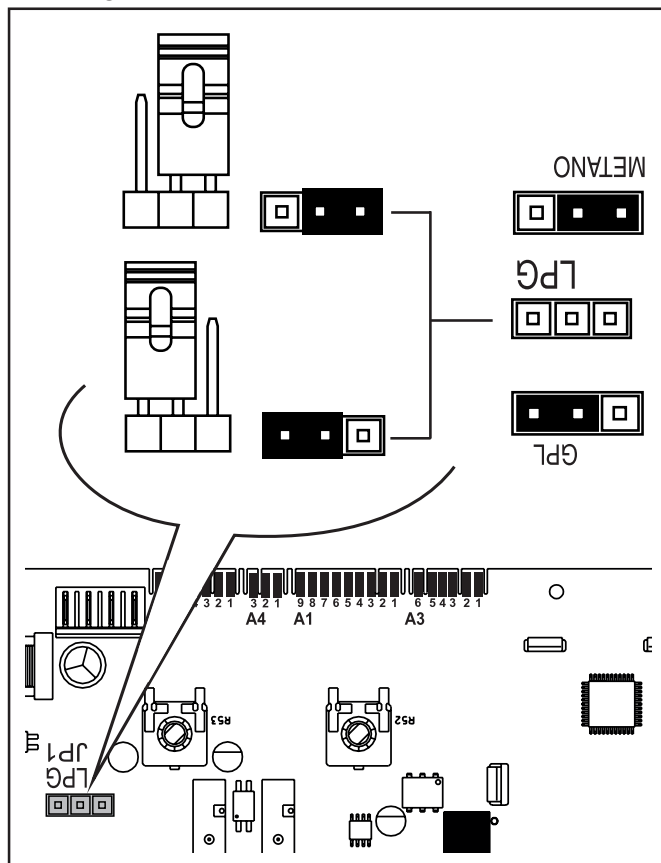

- re-assemble the burner and reconnect it to the electrode;
- access the modulation board contained in the electric panel and position the jumper in the position corresponding to the new type of gas indicated in the figure;



- Close the electric panel and restore the appliance's electric power supply
- check the pressure value upstream of the gas valve (see table "NOZZLES - PRESSURE") and adjust the pressure as indicated in paragraph "3.12";
- check that the burner is working properly;
- check that there are no gas leaks.

- when the conversion is complete, fill in the information required on the label supplied with the kit and apply it next to the technical data label of the boiler.

EXAMPLE OF COMPILATION

	Data - Fecha Date - Datum	08, 09, 05
	Firma - Signature Unterschrift	
- Regolata per	G 20	<input type="checkbox"/>
- Réglée pour	G 25	<input type="checkbox"/>
- Adjusted for	G 30	<input checked="" type="checkbox"/>
- Reglada para	G 31	<input checked="" type="checkbox"/>
- Eingestellt für		

ETI 4530C

4.4 - IMPORTANT NOTES



NOTE

The safety pressure switch against lack of water does not give electric consent for burner start when the pressure is below 0.4 bar.

The water pressure in the heating system must not drop below 0.8/1 bar; open the filling tap on the boiler when the pressure is too low.

This operation must be performed with a cooled system. The pressure gauge fitted on the boiler allows you to read the circuit pressure.



NOTE

If the boiler was without electric power, after a certain idle period, the pump could be blocked. Before electrically powering the boiler, the pump must be unblocked by operating as follows:

Remove the protective screw from the pump centre using a cloth and insert a screwdriver, manually turning the pump's shaft clockwise. After having unblocked the pump, tighten the protective screw and make sure there is no water leakage.



ATTENTION!

After removing the protective screw, a small amount of water could leak out. Dry all wet surfaces before re-assembling the casing.

4.5 - WIRING DIAGRAM

Practical connection board

ENGLISH

COLORI	
BL	BLUE
BR	BROWN
BK	BLACK
G	GREEN
GR	GREY
L BL	LIGHT BLUE
OR	ORANGE
PK	PINK
R	RED
Y	YELLOW
YG	YELLOW/GREEN
WH	WHITE

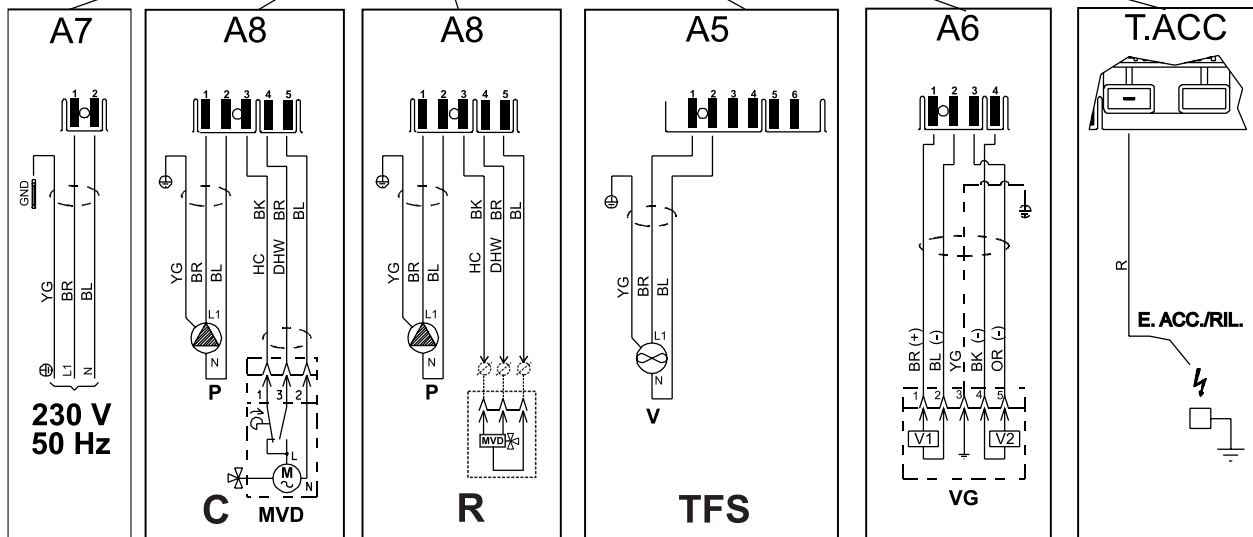
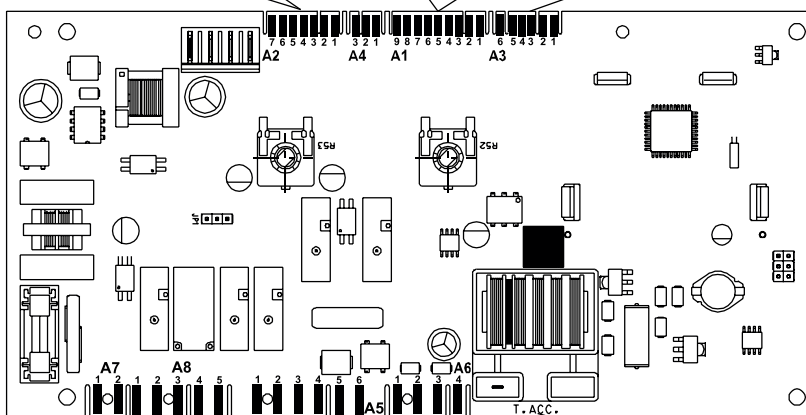
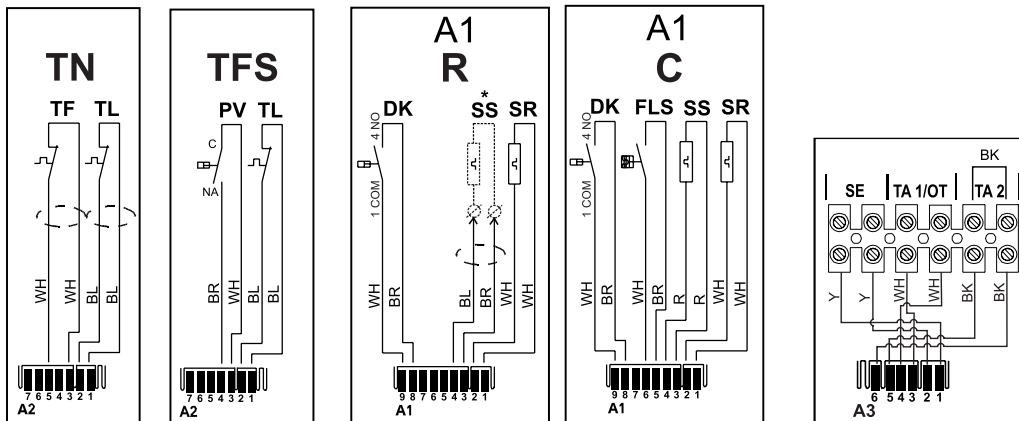

KEY	
A1.....A8	Services connectors
DK	Water deficiency safety pressure switch
E. ACC./RIL	Ignition/detection electrode
FLS	Domestic hot water request flow switch
MVD	Diverter valve motor (SWG P Only)
P	Pump
PV	Fan Pressure Switch (SWG forced draught only)
SR	Heating sensor

SS (*)	DHW probe (SWG C only)
TF	Flue gas thermostat (SWG natural draught only)
TL	Limit thermostat
VG	Gas valve
V	Fan
SE	External probe connection terminals
TA1 / OT	Modulating TA connection terminals
TA2	On/off TA connection terminals

MAINTENANCE INSTRUCTION



service

4.6 - ERROR CODES

The symbol flashes on the display monitor when the boiler detects an anomaly.











1) In the event of an anomaly that does not stop boiler operation, press the **unlock key (D)** to display the error code; in the event the boiler is in stand-by, the error code appears and remains fixed on the display.



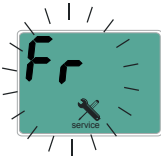









2) In the event of an anomaly that causes boiler down time, the error code flashes directly on the display.

Each fault is characterised by a priority level: if two faults are detected at the same time, the code with the highest priority is displayed. The fault codes are listed below:

(Num) = see key Par. 2.2

SYMBOL	PRIORITY	DESCRIPTION	SOLUTIONS
	0	EXTERNAL PROBE interrupted	Check the wiring, if needed replace the external probe
	2	HIGH TEMPERATURE Boiler temperature too high	Check the operation of pump (12) and clean the exchanger, if required (9)
	3	EXCHANGER FREEZING (9) Exchanger freezing is detected If the heating sensor detects a temperature below 2° C, burner ignition is inhibited until the sensor detects a temperature above 5°C.	Disconnect the from the power supply, close the gas valve, defrost the exchanger carefully.
	4	SAFETY THERMOSTAT Intervention of the safety thermostat (10)	Press the unblock button “D” on the panel and/or check that the thermostat or its connections are not interrupted
	5	DOMESTIC HOT WATER SENSOR Domestic hot water sensor fault (1)	Check the efficiency of the sensor (see table Res/Temp) and its connections.
	6	HEATING SENSOR Heating sensor fault (11)	Check the efficiency of the sensor (see table Res/Temp) and of its connections.
	7	WATER DEFICIENCY Insufficient water pressure and consequent intervention of the minimum water pressure - pressure switch (13).	Restore pressure through the filling valve and check for leaks. Check expansion vessel efficiency.
	8	FAULTY PRESSURE SWITCH (19) Short circuit / Probable condensation in the pressure switch silicone tubes	Check the pressure switch works and the connections to eliminate any condensation residues. Install a specific anti-condensation kit, if required.

	10	EXHAUST PIPE DIFFICULT	TN: Check the flue draught or the flue gas thermostat (7). TFS: Check the operation of the fan and its pressure switch (18) (19). Any flue obstructions. Make sure the flue gas exhaust collector is not present with longer lengths than the manufacturer limit.
	13	BLOCK No gas or failed burner ignition	Check the gas supply and that the ignition/detection electrode is working properly. Pressure shut-off valves.
	14	PARASITE FLAME Flame detected upon ignition (4)	Check the wiring of the Ign/Det. electrode and remove any oxidation, press the un-block key, if the anomaly persists, replace the electrode.
	16	INTERNAL ERROR	Replace the electronic board
	17	LOW VOLTAGE Power supply voltage too low	
	19	ERROR CONFLICT FIRMWARE	Replace the electronic board
	20	ERROR CIRCUIT FLAME	Replace the electronic board
	21	ERROR DRIVER VALVE GAS	Replace the electronic board
	23	ERROR MEMORY INTERNAL	Replace the electronic board
	23	ERROR RESET BUTTON ALWAYS ACTIVE	Check if the button is jammed or glued to the board.
	23	EXCESSIVE NUMBER OF REMOTE RESETS The error code appears after 5 resets in 15 minutes	Disconnect and connect voltage to delete the error code.

schuster®

CE 00335159 - 1st edition 07/14

The manufacturer declines every responsibility for the possible inaccuracies if owed to errors of transcript or press. Also reserves the right to bring those changes that it will hold necessary to its own products or profits, without jeopardizing its essential characteristics.

Schuster - via Padana Inferiore 52/C - 29012 Caorso (PC) - Italy - e-mail: info@schusterboilers.com - www.schusterboilers.com